

**A-SERIES**  
Architectural Collection



**ARCHITECTURAL AUTHENTICITY,  
UNPARALLELED PERFORMANCE**

# CONTENTS

## A-SERIES WINDOWS & PATIO DOORS

Performance .....	3
Glass .....	4
Exterior & Interior Options .....	6
Smart Home .....	8
Door Hardware .....	10
Window Hardware .....	12
Insect Screens .....	13
Grilles .....	15
Alignment .....	16
Joining .....	18
<hr/>	
A-Series Windows .....	19
<hr/>	
A-Series Specialty Windows .....	63
<hr/>	
A-Series Frenchwood® Patio Doors .....	103
<hr/>	
Exterior Trim .....	141
<hr/>	
Combination Designs .....	148
Product Performance .....	160
Installation Accessories .....	170
Sustainability .....	172

For warranty information, visit [andersenwindows.com/warranty](http://andersenwindows.com/warranty).



**The most recognized,  
TRUSTED and RECOMMENDED  
brand of windows and patio doors.\***



Hanley Wood Builder Brand Use Study  
1998-2019  
Windows – Wood & Clad-Wood Category



Hanley Wood Remodeling Brand Use Study  
2006, 2010, 2013, 2015, 2017  
Windows – Wood & Clad-Wood Category



Andersen Corporation, including its subsidiaries, has been named a 2020 ENERGY STAR® Partner of the Year – Sustained Excellence Award winner, the highest honor given by ENERGY STAR for continued leadership in protecting the environment through superior energy efficiency achievements.

\*2018 U.S. Homeowner Brand Study of Andersen and Renewal by Andersen brands vs. competitive brands.  
“ENERGY STAR” is a registered trademark of the U.S. Environmental Protection Agency.



## A-SERIES WINDOWS & PATIO DOORS

Designed in tandem with architects to provide authentic architectural style, A-Series windows and patio doors are our best performing, most energy-efficient products. They share features such as common sight lines, glass setback and sizing so they're easy to work with and easy to specify. Plus, their composite exterior withstands the test of time in coastal environments and is warrantied against corrosion for the life of the product without the need for washing or waxing. With A-Series products, not only is there beauty in the details, there's comfort in knowing they'll last. To learn more, visit [andersenwindows.com/a-series](https://andersenwindows.com/a-series).

Our products with Stormwatch® Protection offer the toughest protection for coastal environments. To stand up to harsh coastal weather conditions, we add structural enhancements such as impact-resistant glass, frame and sash reinforcements and heavy-duty hardware. With Stormwatch Protection on A-Series products, you have the requirements needed to meet strict coastal building codes\*\* for 24/7 protection against the harshest weather conditions. And like all Andersen® products, they're supported by over 115 years of commitment to quality and service and backed by our industry-leading Owner-2-Owner® limited warranty. To learn more, visit [andersenwindows.com/coastal](https://andersenwindows.com/coastal).



\*Visit [andersenwindows.com/warranty](https://andersenwindows.com/warranty) for details.

\*\*See your local code official for building code requirements in your area.



# UNPARALLELED PERFORMANCE

The beauty of A-Series products goes beyond their looks and authentic architectural style. They're also the best-performing, most energy-efficient windows and patio doors we've ever offered. At Andersen, we believe our job is to do more than just make windows and doors. It's also to make you look good to your customers today and for years to come.

## WATER MANAGEMENT THAT WORKS

These features work together to direct water away from buildings:

- Hermetically sealed corner keys keep frames tight
- Sloped sill on double-hung windows
- Sill on patio doors directs water away from the home
- Innovative trim attachment flange secures trim independent of the window or door's water management system

## SEALS OUT THE WEATHER

Weather-resistant seals stand up to eight inches of rain per hour and hurricane-force winds\*. Double-hung windows feature a dual-bulb seal and casement windows use refrigerator-type gaskets to help keep air and water out.

## BUILT STRONG

We use solid wood in interior door panels and window sash and frames, plus fiberglass on outer door frames and window sash exteriors, to provide an unmatched combination of strength, insulation, versatility and beauty.

Additionally, our Fibrex® composite material used in window frames and trim components delivers twice the strength and rigidity of vinyl.



## PERFORMANCE GRADE (PG) UPGRADES FOR PATIO DOORS

Some codes don't require impact-resistant glass. For these situations, Performance Grade (PG) upgrades are available for patio doors.



## EASY CONNECT JOINING SYSTEM

Utilizing the strength and durability of fiberglass, our Easy Connect Joining System provides design flexibility to create large window combinations with the ability to join smaller sub-combinations as you install them into the rough opening. See page 18.

## SUPERIOR PERFORMANCE

A-Series windows with Stormwatch® Protection are designed to satisfy:\*\*

- Large missile impact test ASTM/E1886/E1996
- TAS 201, 202, 203
- AAMA/WDMA/CSA 101/I.S.2/A440-08 &-11

## PG70

**PERFORMANCE**  
FWHD33100HP Impact DPUP +65/-70  
AAMA/WDMA/CSA 101/I.S.2/A440-08 &-11

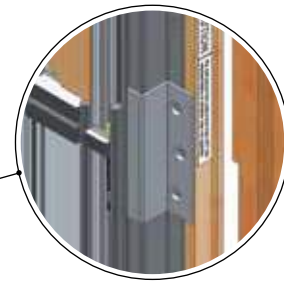

## NO EXPOSED BRACKETS

Hidden structural brackets provide 24/7 protection\*\* and mean no visible reinforcements are necessary to meet coastal product performance requirements.

## RIGOROUSLY TESTED

A-Series products with Stormwatch Protection have withstood testing that has taken them from temperatures as cold as Alaskan winters to the heat of Death Valley summers. They've stood up to hurricane-force winds and prolonged exposure to sea air\*. For product performance, test reports and videos, visit [andersenwindows.com/coastalperformance](http://andersenwindows.com/coastalperformance).

\*Tested to AAMA/WDMA/CSA 101/I.S.2/A440-08 &-11 PG50. For more information, visit [andersenwindows.com/coastal](http://andersenwindows.com/coastal).

\*\*See your local code official for building codes requirements in your area.

# BEST-IN-CLASS GLASS

Choose the exact glass you need to comply with virtually any coastal building code requirement.\* Many A-Series windows and patio doors meet ENERGY STAR® v. 6.0 criteria in all 50 states. Visit [andersenwindows.com/energystar](https://andersenwindows.com/energystar) to verify that the product and glass selected meet ENERGY STAR criteria in your area.

GLASS	ENERGY		LIGHT	
	U-Factor How well a product prevents heat from escaping.	Solar Heat Gain Coefficient How well a product blocks heat caused by sunlight.	Visible Light Transmittance How much visible light comes through a product.	UV Protection How well a product blocks ultraviolet rays.
SmartSun™	● ● ● ○	● ● ● ●	● ● ● ○	● ● ● ●
SmartSun with HeatLock® Coating	● ● ● ●	● ● ● ●	● ● ○ ○	● ● ● ●
Low-E4®	● ● ● ○	● ● ● ○	● ● ● ○	● ● ● ○
Low-E4 with HeatLock Coating	● ● ● ●	● ● ● ○	● ● ● ○	● ● ● ○
Sun™	● ● ● ○	● ● ● ●	● ○ ○ ○	● ● ● ○
Clear Monolithic SmartSun†	○ ○ ○ ○	● ● ○ ○	● ● ● ●	● ● ○ ○
Gray Monolithic SmartSun**†	○ ○ ○ ○	● ● ● ○	● ● ○ ○	● ● ● ○

Center of glass performance only. Ratings based on glass options as of November 2019. Visit [andersenwindows.com/energystar](https://andersenwindows.com/energystar) for ENERGY STAR® map and NFRC total unit performance data.

\*\*Low-E4 Sun impact-resistant glass and gray Monolithic SmartSun impact-resistant glass each satisfy Florida Turtle Code.

†Clear or gray Monolithic SmartSun impact-resistant glass is available on patio doors and patio door sidelights and transoms only.

\*See your local code official for building code requirements in your area.





### HIGH-PERFORMANCE IMPACT-RESISTANT GLASS FOR WINDOWS & PATIO DOORS

**Low-E4® impact-resistant glass** provides all the benefits of monolithic impact-resistant glass, while adding an insulating air space that helps keep homes cool in the summer and warm in the winter.

**Low-E4 SmartSun™ impact-resistant glass** delivers the benefits of Low-E4 impact-resistant glass, plus it helps shield homes from the sun's heat and filters out 95% of harmful UV rays while letting sunlight shine through.

**Low-E4 Sun impact-resistant glass** is tinted for maximum protection from the effects of intense sunlight and provides all the benefits of Low-E4 impact-resistant glass.

A white interlayer and obscure glass are also available, see your Andersen supplier for details.

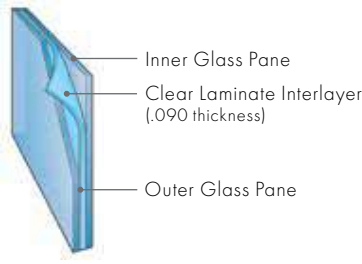

### MONOLITHIC IMPACT-RESISTANT GLASS FOR PATIO DOORS

**Monolithic SmartSun impact-resistant glass** is reinforced with a clear laminate interlayer sandwiched between two panes of glass to resist impact, forced entry and unwanted noise. Choose from clear monolithic or gray monolithic that's tinted to further block heat caused by sunlight. Available on patio doors and patio door sidelights and transoms only.

A white interlayer is also available, see your Andersen supplier for details.



### HIGH-PERFORMANCE GLASS FOR NON-COASTAL PATIO DOORS WITH PERFORMANCE GRADE (PG) UPGRADES

**Low-E4 glass** provides an insulating air space that helps keep homes cool in the summer and warm in the winter.

**Low-E4 SmartSun glass** delivers the benefits of Low-E4 glass, plus it helps shield homes from the sun's heat and filters out 95% of harmful UV rays while letting sunlight shine through.

**Low-E4 Sun glass** is tinted for maximum protection from the effects of intense sunlight and provides all the benefits of Low-E4 glass.



**Storm Protection**  
helps protect homes against extreme weather and flying debris



**Sound Reduction**  
reduces exterior noise for a quieter environment



**Safety**  
provides forced-entry resistance for peace of mind



**Sun Protection**  
helps reduce damaging UV rays from coming into the home



**Help Save Energy**  
helps shield homes from the sun's heat, keeping homes cool and lowering energy costs

### HEATLOCK® TECHNOLOGY

Applied to the room-side glass surface, HeatLock coating reflects heat back into the home for improved performance.

### TURTLE GLASS

Turtle glass requirements can be achieved by using the Low-E4 Sun glass option, see your Andersen supplier for details.

### TIME-SAVING FILM

We protect our products during delivery and construction with translucent film on the glass that peels away for a virtually spotless window.



## EXTERIOR OPTIONS TO MATCH ANY STYLE

A-Series products are available in a variety of exterior colors and exterior trim styles. Even in harsh conditions, they're virtually maintenance-free, hold their original vibrant colors, never need painting and won't flake, blister, crack, peel, pit, corrode or lose adhesion.\* Plus, they're warranted against corrosion for the life of the products,\*\* with no washing or waxing required.\* Select any combination of colors shown here for your exterior frame, sash and trim. For information on our exterior trim style options, see page 141.

### EXTERIOR COLORS



\*Visit [andersenwindows.com/warranty](http://andersenwindows.com/warranty) for details.

\*\*Hardware excluded.

Printing limitations prevent exact duplication of colors. See your Andersen supplier for actual color samples.



# INTERIOR OPTIONS TO MATCH ANY VISION

With six natural wood species, a variety of painted interiors and six, rich factory-finished stain options, A-Series products provide the flexibility you need to create interiors that please both you and your customers.

## INTERIOR WOOD SPECIES



## FACTORY-FINISHED INTERIORS

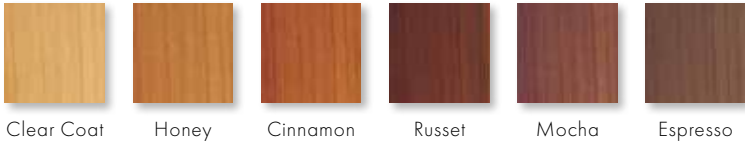

Shown on pine. Available on pine, maple and oak only.

## INTERIOR PAINTED OPTIONS

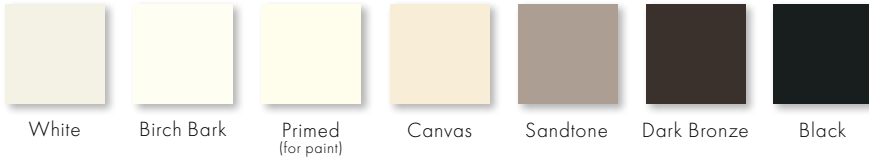

Available on pine. Additional colors to match all 11 exterior colors are also available, contact your Andersen supplier.

\*Actual wood is either Sapele or Sipo, both non-endangered species grown in Africa, with color and characteristics similar to Central American mahoganies. Naturally occurring variations in grain, color and texture of wood make each window one of a kind. We cannot guarantee consistency in wood grain and/or color within a particular species, product or project. Printing limitations prevent exact replication of colors and finishes. See your Andersen supplier for actual color and finish samples.



# THE SMARTEST TECHNOLOGY FOR THE SMARTEST HOMES

Andersen® A-Series products can be part of today's connected home allowing homeowners to manage the status of their windows and patio doors anytime and from anywhere. Learn more about managing security and the convenience and peace of mind Andersen smart home products offer at [andersenwindows.com/connect](http://andersenwindows.com/connect).



A monitoring option for every home and lifestyle.

## WIRELESS OPEN/CLOSED SENSORS

These wireless sensors provide the peace of mind of knowing whether windows and patio doors are open or closed.\*

### Easy Installation

No tools are required to install our sensors. Simply place the sensor on a window or door and line up the magnet with the sensor until the LED glows blue.\*\*

### Maintains Warranty

No drilling required which can void warranties.

### Compact Design

Sleek, compact design for a clean appearance and color options to blend in with the window or door interior.



Open/closed sensor shown in white.



\*When properly configured and maintained with a professionally installed security system and/or self-monitoring system compatible with Honeywell® 5800 controls. See your Andersen supplier for more information.

\*\*See product installation for details.

## VERILOCK® SECURITY SENSORS

With the most advanced technology in the industry, our patented VeriLock security sensors not only indicate whether windows and patio doors are open or closed, they even tell you if they are locked or unlocked\*. No other sensor can do that.

### Maintains Warranty

No drilling required which can void warranties.

### Helps Maximize Energy Efficiency

Windows that are closed but unlocked, lose air at a rate up to 3X that of a closed and locked window.\*\* VeriLock sensors tell you which windows and doors are open or unlocked\* so you can help manage air loss.\*\*

### Preserves Beauty

Color options available to complement many Andersen hardware or interior finishes.



VeriLock sensor shown in white with Newbury® hardware in satin nickel.

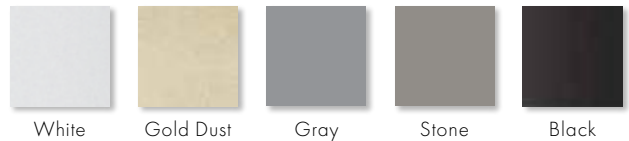

## YALE® ASSURE LOCK® FOR HINGED PATIO DOORS†

Never worry about carrying or losing keys again. Monitor, lock and unlock from anywhere with the Yale Assure Lock. The sleek key-free lock includes Bluetooth® technology for keyless unlocking and is compatible with Z-Wave® for integration with a wide range of smart home platforms. Yale Assure Lock is available with Anvers® hardware.

### One-Touch Locking

Lock up without the hassle of keys by simply tapping the keypad.

### Key Free

No cylinder means no lost keys and no pick and bump break-ins.

### Battery Back-Up

Never lose power, the lock can be energized with a 9V battery.

### VeriLock Security Sensors

Know whether your doors are open, closed, locked or unlocked.\*

### Smart Home Integration

Monitor, lock and unlock from anywhere.



Yale Assure Lock shown in satin nickel.



\*When properly configured and maintained with a professionally installed security system and/or self-monitoring system compatible with Honeywell® 5800 controls. See your Andersen supplier for more information.

\*\*Based on testing of thirty-two (32) A-Series double-hung windows. Air loss through unlocked windows will vary based on window type and age, pressure differential, temperatures inside and outside the home, altitude and application.

†Available on select Andersen® hinged patio doors, see your Andersen supplier for details.

All marks where denoted are trademarks of their respective owners. Yale manufactures and supports the limited warranty for Yale Assure Lock for Andersen patio doors.

# HARDWARE FOR EVERY DOOR, STYLES FOR EVERY HOME

A-Series patio door hardware\* is available in a variety of different designs to match virtually any style. Yuma®, Encino®, Anvers®, Newbury®, Covington™ and Whitmore® hardware options each feature solid, drop-forged brass for added strength, while Albany and Tribeca® hardware options are made of diecast zinc with durable powder-coated finishes. Additional hardware options such as exterior keyed locks, matching hinge finishes and more are also available. For corrosion-resistant hardware, see pages 105 or 106.



**YUMA®**

Distressed Bronze  
**Distressed Nickel**

**ENCINO®**

**Distressed Bronze**  
Distressed Nickel

**NEWBURY®**

Antique Brass | Bright Brass  
Brushed Chrome | **Oil Rubbed Bronze**  
Polished Chrome | Satin Nickel

**ANVERS®**

Bright Brass | Oil Rubbed Bronze  
**Satin Nickel**

Bold name denotes finish shown.

## FSB® HINGED PATIO DOOR HARDWARE

Durable, stainless steel FSB hinged door hardware features clean lines and a sleek satin finish for a thoroughly modern look. Choose from four handle styles.



Satin  
Stainless  
Steel



\*Hardware sold separately.

“FSB” is a registered trademark of Franz Schneider Brakel GmbH & Co.



Gliding

Hinged

**COVINGTON™**

Antique Brass | **Bright Brass**  
Oil Rubbed Bronze



Gliding

Hinged

**WHITMORE®**

Antique Brass | Bright Brass  
Oil Rubbed Bronze | Satin Nickel



Gliding

Hinged

**ALBANY**

Black | **Gold Dust**  
Stone | White



Gliding

Hinged

**TRIBECA®**

Stone | **White**



**HARDWARE FINISHES**



Matching hinges available in most hardware finishes for inswing patio doors, excludes FSB® hardware. Distressed bronze and oil rubbed bronze are "living" finishes that will change with time and use. Bright brass and satin nickel finishes feature a 10-year limited warranty. Printing limitations prevent exact replication of finishes. See your Andersen supplier for actual finish samples.

# BEAUTY IN THE DETAILS

The hardware\* for our A-Series coastal windows is created exclusively for Andersen and is made of forged metal for added strength. A range of available finishes makes it easy for customers to coordinate their window hardware with their cabinet hardware, faucets and other room décor. For corrosion-resistant hardware, see page 23.

## Casement & Awning



### CONTEMPORARY FOLDING

**Black** | Bright Brass | Gold Dust  
Satin Nickel | Stone | White



### TRADITIONAL FOLDING

**Antique Brass** | Black | Bright Brass | Brushed Chrome  
Distressed Nickel | Gold Dust | Polished Chrome  
Satin Nickel | Stone | White

Folding handles avoid interference with window treatments.  
Bold name denotes finish shown.

## Double-Hung



Lock & Keeper

Antique Brass | Black | Bright Brass | Brushed Chrome | Distressed Nickel  
Gold Dust | Polished Chrome | **Satin Nickel** | Stone | White



Bar Lift



Finger Lift



Hand Lift

### TRADITIONAL LIFTS

Antique Brass | Black | Bright Brass | Brushed Chrome | Distressed Nickel  
Gold Dust | Polished Chrome | **Satin Nickel** | Stone | White

Bold name denotes finish shown.

## HARDWARE FINISHES



Antique Brass



Black



Bright Brass



Brushed Chrome



Distressed Nickel



Gold Dust



Polished Chrome



Satin Nickel



Stone



White

\*Hardware sold separately except double-hung lock and keeper.

Printing limitations prevent exact replication of colors and finishes. See your Andersen supplier for actual color and finish samples.

# SCREENS OUT THE INSECTS, NOT THE VIEW

Optional insect screens are available for all venting A-Series products.



## TRUSCENE® INSECT SCREENS

Made with a micro-fine stainless steel mesh, exclusive Andersen® TruScene insect screens provide 50% greater clarity than our conventional insect screens. They let more fresh air and sunlight in, while doing a better job of keeping small insects out. Exterior TruScene insect screen frames are available in all standard exterior colors. Interior insect screens are available with prefinished wood veneer frames and all interior painted options.



Prefinished wood frame options are available for casement and awning windows in six wood veneers and six stain colors to match the interior finish.

Pine frame with clear finish is shown.

TruScene insect screens are not available on patio doors. All comparisons are made to Andersen aluminum-mesh insect screens.

## CONVENTIONAL INSECT SCREENS

For casement and awning windows, aluminum insect screen frames are available in stone, white or gold dust (shown to the right from the interior) and all interior painted options – Sandtone, canvas, dark bronze and black. Insect screen frames for all other windows are installed on the exterior of the window and match the unit's exterior color.



Stone



White



Gold Dust

## WINDOW CONFIGURATIONS

Full insect screens are available for all venting windows. Our double-hung windows also have the option of insect screens that cover only the lower sash.



Full

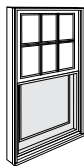

Half

## PATIO DOOR CONFIGURATIONS

A-Series patio doors feature Andersen fiberglass insect screens and are available in several styles, including a premium top-hung gliding design for gliding and hinged doors.

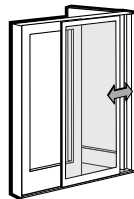

Premium top-hung gliding design, shown on an inswing door, is also available for two- and four-panel gliding doors.

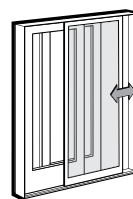

Conventional gliding, shown on a two-panel gliding door, is also available for four-panel gliding doors and two-panel inswing doors.

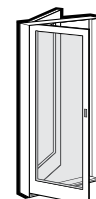

Hinged, shown on a single-panel inswing door, is also available for two-panel inswing doors.

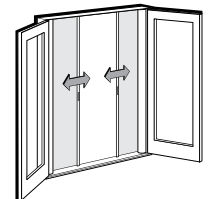

Retractable, shown on a two-panel outswing door, is also available for single-panel doors. A retractable insect screen is also available for gliding doors.





# GRILLES FOR EVERY HOME

A-Series windows and patio doors offer a variety of architecturally authentic grille types and standard patterns. We'll also work with you to provide your customers with custom grille designs for a signature look.

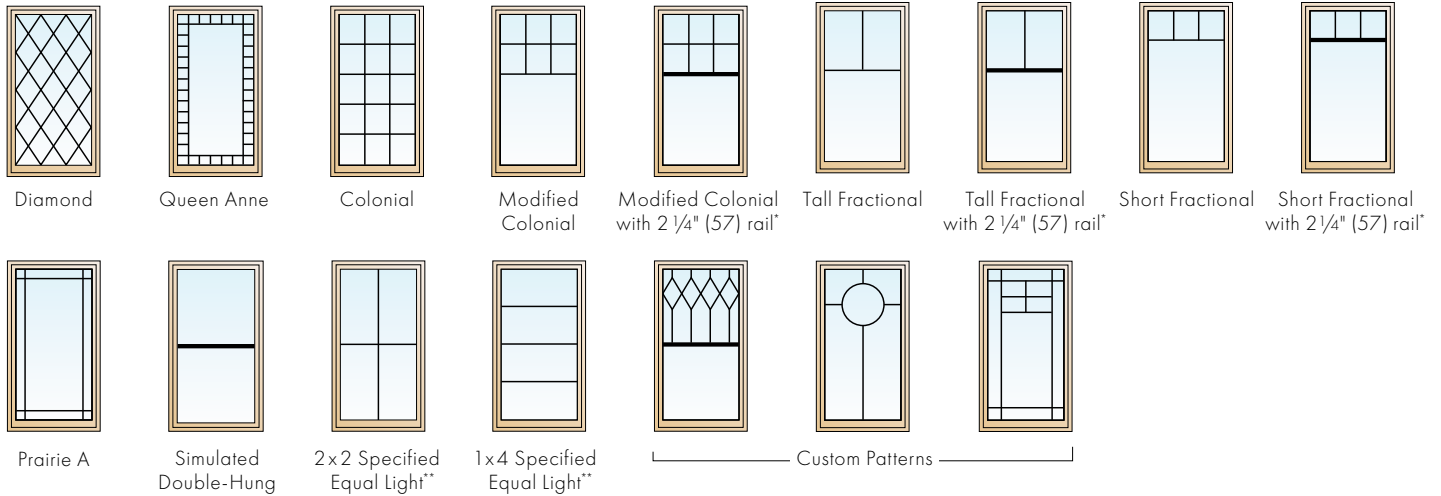

For standard grille patterns, refer to the detailed product sections in this product guide or contact your Andersen supplier. Some grille patterns are not available in all configurations or for all products.

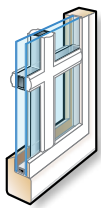

Permanent exterior  
Permanent interior  
with spacer



Permanent exterior  
Permanent interior



Permanent exterior  
Removable interior

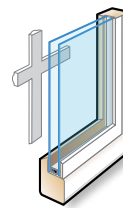

Removable interior



Finelight Grilles-Between-the-Glass†

## FULL DIVIDED LIGHT

Permanently applied to the interior and exterior of your window with a spacer between the glass.

## SIMULATED DIVIDED LIGHT

Permanent grilles on the exterior and interior with no spacer between the glass. We also offer permanent exterior grilles with removable interior grilles available in natural wood or prefinished white.

## CONVENIENT CLEANING OPTIONS

Removable interior grilles come off for easy cleaning. Andersen® Finelight™ grilles-between-the-glass are installed between the glass panes and feature a contoured 3/4" (19) profile.

## Grille Bar Widths

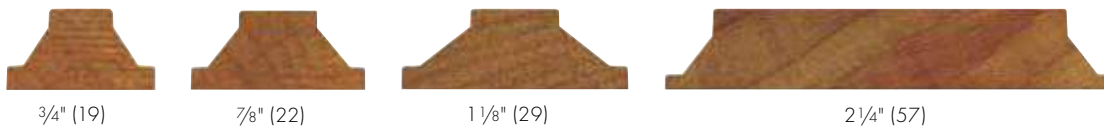

Actual size shown.

Our 2 1/4" (57) width grille can be positioned horizontally across the center of a casement window to simulate the look of a double-hung window.

\*Simulated check rails are also available in 7/8" (22) and 1 1/8" (29) widths.

\*\*Specify number of same-size rectangles wide or high. Some restrictions may apply.

† 7/8" (22), 1 1/8" (29) and 2 1/4" (57) are not available in Finelight grilles-between-the-glass.

Dimensions in parentheses are in millimeters.

# UNCOMMON PRECISION

## COMMON SIZE GRID

Common sizes in four-inch increments are based on the rough opening to simplify framing and specifying. Even-inch sizes eliminate fractions and reduce jobsite errors. A  $\frac{3}{4}$ " (19) gap horizontally and vertically leaves room for shims, insulation and sill flashing.

## CUSTOM SIZING

All Andersen® A-Series windows and patio doors can be ordered in  $\frac{1}{8}$ " (3) increments, providing flexibility for replacement, remodeling, new construction or light commercial projects.

## COMMON GLASS SETBACK

A common glass setback on A-Series windows and patio doors delivers noticeably clean shadow lines both inside and out.

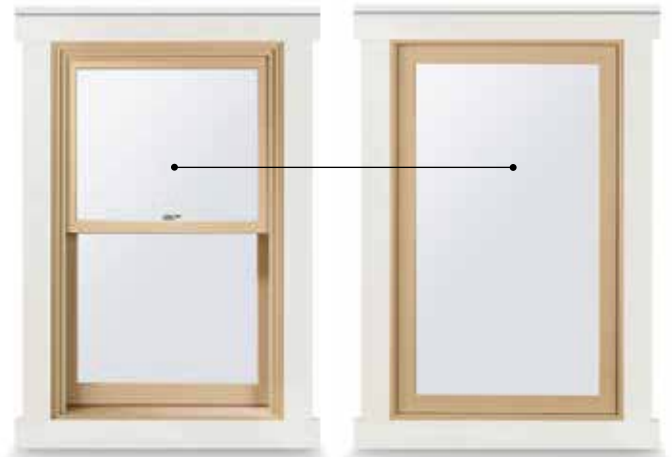

The upper sash of double-hung windows align perfectly with casement windows, awning windows, picture windows, patio doors and transoms.

Dimensions in parentheses are in millimeters.



## COMPLETE ALIGNMENT

Common sight lines allow you to specify any combination of window styles and still have them match and align perfectly.



Windows share the same sash design, grille profiles and frame depth for consistent beauty with classic appeal.

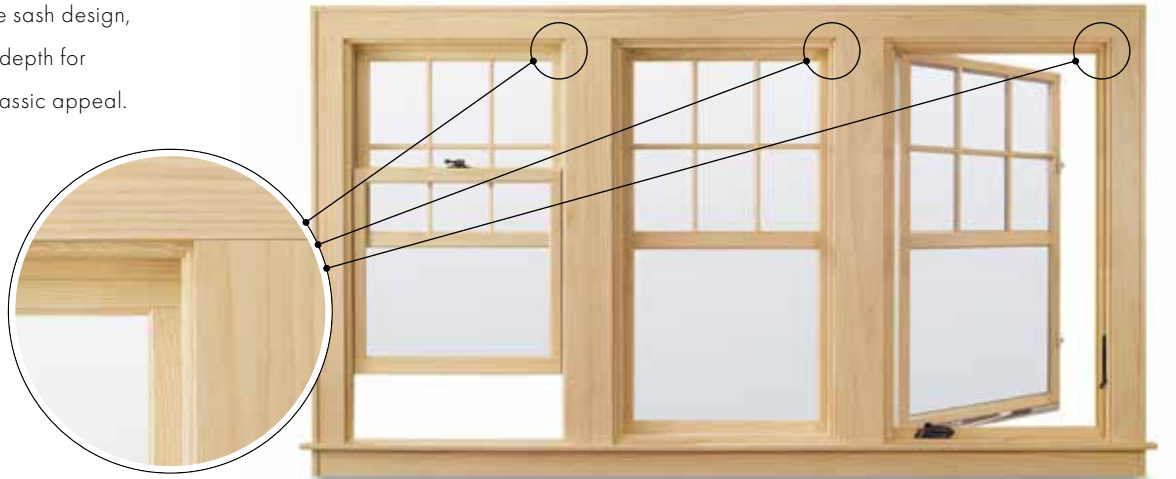

## EASY MATH

The A-Series window system simplifies selection and installation of multiple windows within a single rough opening.  $\frac{3}{4}$ " (19) horizontal and vertical joints keep sizing consistent no matter how many or what size windows you combine.

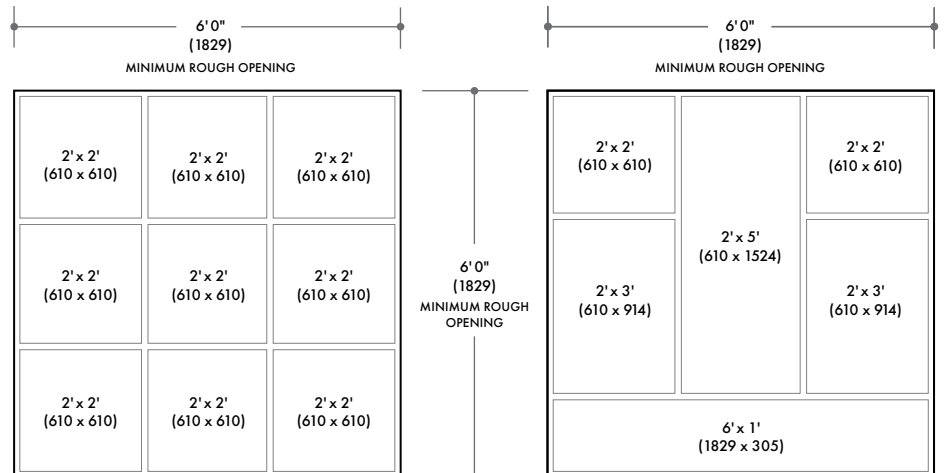

The spacing in these illustrations is exaggerated for demonstration purposes.

# THE ULTIMATE IN JOBSITE CONVENIENCE

Andersen® reinforced joining\* options provide enhanced performance, design flexibility and jobsite conveniences. These joining options utilize the strength and durability of fiberglass joining material and offer the design flexibility of achieving both one-way and two-way joins. For patio door combinations, use our reinforced kits. Visit [andersenwindows.com/joining](http://andersenwindows.com/joining) for more details and to see a joining demonstration video.

This innovative patented system utilizes 5 3/4" (146) interlocking fiberglass joining plates for 4 9/16" (116) base jamb depths. 7 3/4" (197) interlocking fiberglass joining plates are available for higher performance and are required for Frenchwood® hinged inswing patio doors with 6 9/16" (167) base jamb depths. They are available in 14' (4267) lengths and are field cut and applied.

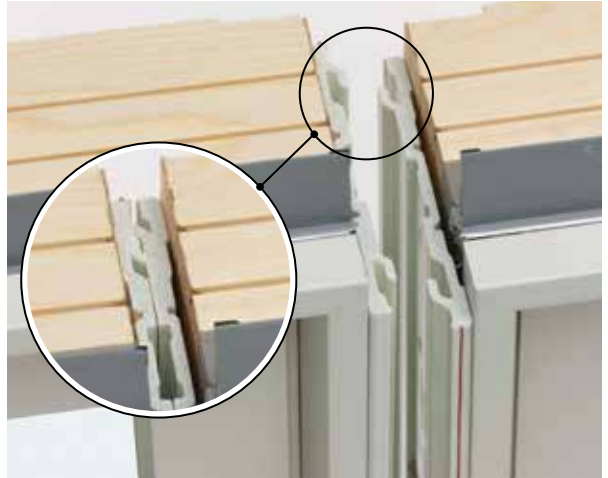

## EASY CONNECT JOINING SYSTEM

Receive lighter, easier-to-handle, pre-assembled smaller combinations that join together as you install them into the rough opening, making it easier to install large combinations. In fact, most contractors surveyed said they could reduce the number of installers by 50% using the Andersen Easy Connect Joining System.\*\*

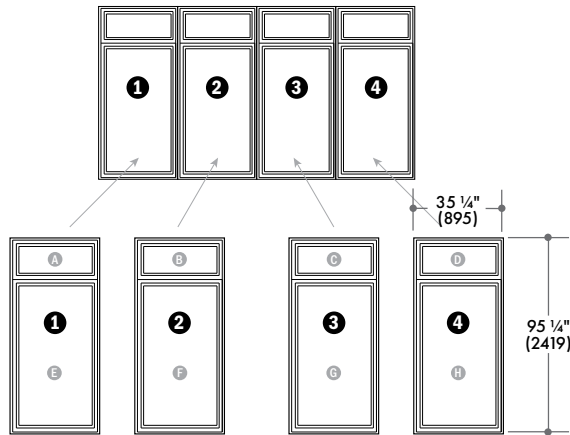

4 groups, 1 over 1 combination

Weight of each combination shown with Low-E4® impact-resistant glass is approximately 154 lbs or 69.85 kg

## FACTORY-JOINED COMBINATIONS

Eliminate the need for jobsite assembly and receive fully joined, factory-assembled window combinations to fit rough openings up to 12' x 8' or 8' x 12'.

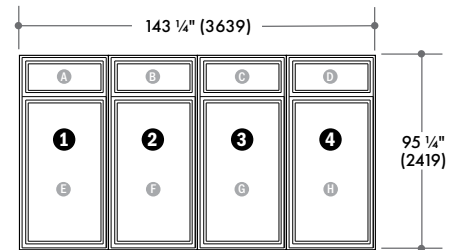

1 group, 4 over 4 combination

Combination weight shown with Low-E4 impact-resistant glass is approximately 616 lbs or 279.41 kg

	Reinforced Easy Connect Joining System	Reinforced Factory-Joined Combinations	Reinforced Joining Kits
Assembly	IN THE OPENING	FACTORY	JOBSITE
Ready to Install in the Opening	•	•	
Number of Installers Needed**	FEWER	MORE	MORE
Hallmark Certified for Air, Water & Structural Performance†	•	•	•
Tested to AAMA 450	•	•	•
High Velocity Hurricane Zone (HVHZ) Approved	•	•	•
Combination Size Limitation	MAX. JOIN LENGTH: 12' (3658) in one direction, no max. in the other direction	MAX. JOIN LENGTH: 12' x 8' or 8' x 12' (3658 x 2438 or 2438 x 3658)	MAX. JOIN LENGTH: 12' (3658) in one direction, no max. in the other direction

\*\*69% of 156 builders/general contractors in a 2018 survey said they could reduce the number of installers by half using the Easy Connect Joining System when comparing the installation of a 12' wide x 8' high pre-assembled window combination unit with four 3' wide x 8' high window combination units.

†When installed according to Andersen installation instructions.

Dimensions in parentheses are in millimeters.

# WINDOWS

**Casement**

- Tables of Sizes ..... 24-25
- Specifications ..... 26-29
- Grille Patterns ..... 35
- Window Details ..... 29

**Awning**

- Tables of Sizes ..... 30-31
- Specifications ..... 32-34
- Grille Patterns ..... 35
- Window Details ..... 35

**Double-Hung**

- Tables of Sizes ..... 36-37
- Specifications ..... 38-40
- Grille Patterns ..... 41
- Window Details ..... 41

**Picture**

- Tables of Sizes ..... 42-46
- Specifications ..... 47-49
- Grille Patterns ..... 45
- Window Details ..... 49

**Transom**

- Tables of Sizes ..... 50-53
- Specifications ..... 52-55
- Grille Patterns ..... 55
- Window Details ..... 56

- Joining Details ..... 57-59
- Custom Sizing ..... 60-62
- Combination Designs ..... 148
- Product Performance ..... 160



Dimensions in parentheses are in millimeters.



## FEATURES

### CASEMENT & AWNING

#### FRAME

**A** Frame constructed with a wood core and Fibrex® composite material exterior. This construction produces a rigid frame and a low-maintenance, durable exterior.

**F** Factory-applied installation clips are standard for anchoring to the building. See “Common Features” for details.

**B** Wood members are treated with a water-repellent preservative for long-lasting\* protection and performance.

**G** The weatherstrip system combines an exterior watershed design and a foam weatherstrip seal between the sash and frame, providing a long-lasting, energy-efficient barrier against wind, water and dust.

**D** A factory-applied rigid vinyl installation flange helps seal the unit to the structure. Available in a standard design or with an exterior trim installation flange (shown). The exterior trim installation flange allows for Andersen® exterior trim surrounds to be applied in seconds after window installation.

#### SASH

**E** Fiberglass construction with wood interior provides durable, strong and long-lasting\*\* performance. Fiberglass is finished with a Flexacron® paint system. This stabilized polyester paint is electrostatically applied for maximum protection and a lustrous, low-maintenance finish.

Traditional architectural style:

- Classic chamfer detailing
- The look of mortise-and-tenon joinery
- Tall bottom rail on casement and awning windows aligns with double-hung and picture windows for common sight lines

**F** Natural wood interiors are treated with a water-repellent preservative for long-lasting\* protection and performance. Interior stops are fastened using a compression fit system so there are no nail holes to fill.



#### G GLASS

See “Common Features” for details.

#### HARDWARE

##### Smooth Control Hardware System

Smooth operation provided by a worm gear drive design makes opening and closing almost effortless, regardless of unit size. Hinges allow for a wash mode or widest clear opening depending on window size. Hardware is sold separately. Hardware option and finish must be specified.

##### Single-Action Casement Lock



Single-action lock easily releases all locking points on casement sash while the reach-out action eliminates binding when closing. The lock is offered in finishes that coordinate with your specified hardware option.

##### Awning Sash Locks

Awning windows feature dual sash locks. Hardware style and finish options are compatible with casement windows to ensure consistency in appearance when used in combination designs.

### DOUBLE-HUNG

#### FRAME

**A** Frame constructed with a wood core and Fibrex composite material exterior. This construction produces a rigid frame and a low-maintenance, durable exterior.

**F** Factory-applied installation clips are standard for anchoring to the building. See “Common Features” for details.

**B** Wood members are treated with a water-repellent preservative for long-lasting\* protection and performance.

**G** The dual weatherstrip system utilizes a double foam-filled design that creates a pressure equalization chamber, knocking down driving rain and delivering a long-lasting, energy-efficient barrier against wind, water and dust.

**D** Traditional sloped sill design.

**E** For units with white exterior, exterior jamb liner is white. For all other exterior colors, the exterior jamb liner is Sandtone. All double-hung windows include lower jamb liner cover/inserts that match the window exterior color.

**F** A factory-applied rigid vinyl installation flange helps seal the unit to the structure. Available in a standard design or with an exterior trim installation flange (shown). The exterior trim installation flange allows for Andersen exterior trim surrounds to be applied in seconds after window installation.

#### SASH

**G** Fiberglass construction with wood interior provides durable, strong and long-lasting\*\* performance. Fiberglass is finished with a Flexacron paint system. This stabilized polyester paint is electrostatically applied for maximum protection and a lustrous, low-maintenance finish.

Traditional architectural style:

- Classic chamfer detailing
- The look of mortise-and-tenon joinery
- Tall bottom rail on double-hung windows aligns with casement, awning and picture windows for common sight lines



**H** Natural wood interiors are treated with a water-repellent preservative for long-lasting\* protection and performance. Interior stops are fastened from behind so there are no nail holes to fill.

#### I GLASS

See “Common Features” for details.

#### HARDWARE

##### Sash Locks



**F** Dual locks with traditional spoon design have an easy Tilt to Clean feature integrated into the lock.

#### SASH OPTIONS\*\*



Cottage Style      Reverse Cottage Style

Lighthouse indicates differences from standard unit or optional upgrades.

\*Visit [andersenwindows.com/warranty](http://andersenwindows.com/warranty) for details.

\*\*Shown on 400 Series tilt-wash double-hung full-frame windows.

“Flexacron” is a registered trademark of PPG Industries, Inc.

## PICTURE WINDOW & FIXED TRANSOM

### FRAME

Frame constructed with a wood core and fiberglass exterior. This construction produces a rigid frame and a low-maintenance, durable exterior.

 Factory-applied installation clips are standard for anchoring to the building. See "Common Features" for details.

Wood members are treated with a water-repellent preservative for long-lasting\* protection and performance.

A factory-applied rigid vinyl installation flange helps seal the unit to the structure. Available in a standard design or with an exterior trim installation flange. The exterior trim installation flange allows for Andersen® exterior trim surrounds to be applied in seconds after window installation.

Fiberglass construction with wood interior provides durable, strong and long-lasting\* performance. Fiberglass is finished with a Flexacron® paint system. This stabilized polyester paint is electrostatically applied for maximum protection and a lustrous, low-maintenance finish.

Traditional architectural style:

- Classic chamfer detailing
- The look of mortise-and-tenon joinery
- Tall bottom rail on picture window aligns with casement, awning and double-hung windows for common sight lines
- Shorter bottom rail on fixed transom provides an attractive sight line when joined above other A-Series windows or patio doors

Natural wood interiors are treated with a water-repellent preservative for long-lasting\* protection and performance. Interior stops are fastened using a compression fit system so there are no nail holes to fill.

### GLASS

See "Common Features" for details.

## VENTING TRANSOM

### FRAME

Frame constructed with a wood core and Fibrex® composite material exterior. This construction produces a rigid frame and a low-maintenance, durable exterior.

 Factory-applied installation clips are standard for anchoring to the building. See "Common Features" for details.

Wood members are treated with a water-repellent preservative for long-lasting\* protection and performance.

The weatherstrip system combines an exterior watershed design and a foam weatherstrip seal between the sash and frame, providing a long-lasting, energy-efficient barrier against wind, water and dust.

A factory-applied rigid vinyl installation flange helps seal the unit to the structure. Available in a standard design or with an exterior trim installation flange. The exterior trim installation flange allows for Andersen exterior trim surrounds to be applied in seconds after window installation.

### SASH

Fiberglass construction with wood interior provides durable, strong and long-lasting\* performance. Fiberglass is finished with a Flexacron paint system. This stabilized polyester paint is electrostatically applied for maximum protection and a lustrous, low-maintenance finish.

Traditional architectural style:

- Classic chamfer detailing
- The look of mortise-and-tenon joinery
- Shorter bottom rail provides an attractive sight line when joined above other A-Series windows or patio doors

Natural wood interiors are treated with a water-repellent preservative for long-lasting\* protection and performance. Interior stops are fastened using a compression fit system so there are no nail holes to fill.

### GLASS

See "Common Features" for details.

### HARDWARE

Smooth operation provided by a worm gear drive design makes opening and closing almost effortless, regardless of unit size.

### Venting Transom Sash Locks

Venting transoms feature dual sash locks. Hardware style and finish options are compatible with casement windows to ensure consistency in appearance when used in combination designs.

## COMMON FEATURES

### GLASS

 Impact-resistant glass construction provides industry-leading energy performance, sound control and added security.

High-Performance options include:

- Low-E4® Impact-Resistant glass
- Low-E4 HeatLock® Impact-Resistant glass
- Low-E4 Sun Impact-Resistant glass
- Low-E4 SmartSun™ Impact-Resistant glass
- Low-E4 SmartSun HeatLock Impact-Resistant glass

Tempered laminated and obscure glass options are available, contact your Andersen supplier.

A removable translucent film helps shield the glass from damage during delivery and construction and also simplifies finishing at the jobsite.

### FRAME

#### Installation Clip



 Mounted around the perimeter of the unit, factory-applied installation clips rotate into position and can be bent into place against the framing members to suit all jamb conditions.

\*Visit [andersenwindows.com/warranty](http://andersenwindows.com/warranty) for details.

"Flexacron" is a registered trademark of PPG Industries, Inc.

EXTERIOR & INTERIOR OPTIONS

EXTERIOR COLORS



INTERIOR WOOD SPECIES



FACTORY-FINISHED INTERIORS

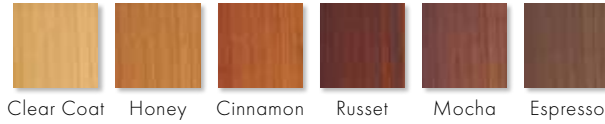

Naturally occurring variations in grain, color and texture of wood make each window one of a kind. All wood interiors are unfinished unless a finish is specified.

Shown on pine. Available on pine, maple and oak only.

INTERIOR PAINTED OPTIONS

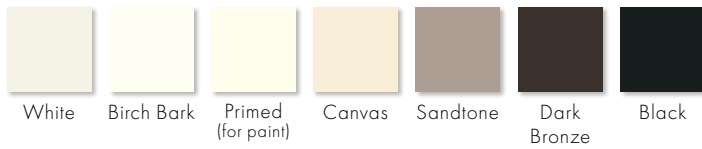

Available on pine. Additional colors to match all 11 exterior colors are also available, contact your Andersen supplier.

HARDWARE OPTIONS\*\*

Casement, Awning & Venting Transom



TRADITIONAL FOLDING HANDLE

Antique Brass | Black | Bright Brass | Brushed Chrome  
Distressed Nickel | Gold Dust | Polished Chrome  
Satin Nickel | Stone | White



CONTEMPORARY FOLDING HANDLE

Black | Bright Brass | Gold Dust  
Satin Nickel | Stone | White

Folding handles avoid interference with window treatments.  
Bold name denotes finish shown.

Double-Hung



Lock & Keeper

Antique Brass | Black | Bright Brass | Brushed Chrome | Distressed Nickel  
Gold Dust | Polished Chrome | **Satin Nickel** | Stone | White



Bar Lift



Hand Lift



Finger Lift

TRADITIONAL LIFTS

Antique Brass | Black | Bright Brass | Brushed Chrome | Distressed Nickel  
Gold Dust | Polished Chrome | **Satin Nickel** | Stone | White

Bold name denotes finish shown.

HARDWARE FINISHES

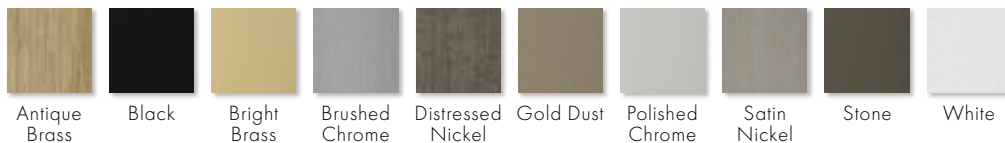

\*Actual wood species is either Sapele or Sipo, both non-endangered species grown in Africa, with color and characteristics similar to Central American mahoganies.

\*\*Hardware sold separately except double-hung lock & keeper.

Printing limitations prevent exact replication of colors and finishes. See your Andersen supplier for actual color and finish samples.



**ACCESSORIES** Sold Separately

**FRAME**
**Extension Jamb**

Extension jambs are available in pine, maple, oak, cherry, mahogany\* and vertical grain Douglas fir, pre-cut to fit your unit. Available in 1/16" (1.5) increments up to 7 1/8" (181) and can be prefinished in six stain colors as well as all interior painted options to match the interior of the unit. This option is also available factory applied.

**Stools for Double-Hung Windows**

Available in all six wood species and all prefinished options. Stools are available for 4 9/16" (116), 5 1/4" (133), 6 9/16" (167) and 7 1/8" (181) wall depths.

**HARDWARE**
**Corrosion-Resistant Hinges, Screws and Operators**

Casement, awning and venting transoms give you the option of corrosion-resistant stainless steel components and are recommended for applications within two miles of the coast and for other harsh environments.\*\*

**Window Opening Control Device**

A window opening control device is available for all A-Series venting windows, which limits opening the sash to less than 4" (102) when the window is first opened. Available factory-applied or as a kit, check with your Andersen supplier. Shown on a casement window.

**Vent Limiter**

A vent limiter is available for most A-Series venting windows, which prevents opening the sash more than 4" (102).

**SECURITY SENSORS**
**VeriLock® Sensors**

VeriLock sensors are available in five colors. See page 9 for details.

**Open/Closed Sensors**

Wireless open/closed sensors are available in four colors. See page 8 for details.

**INSECT SCREENS**
**Full or Half Window Insect Screens**

Full insect screens are available for all venting windows. Andersen also offers the option of half insect screens for the lower sash of our double-hung windows.

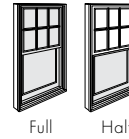
**Conventional Insect Screens**

Aluminum insect screens are available with frames finished in white, stone, gold dust and in all interior painted options for casement, awning and venting transom windows. Insect screens for double-hung windows match product exterior.

**TruScene® Insect Screen**

Exclusive Andersen® TruScene insect screens provide over 50% more clarity than our conventional insect screens for a beautiful unobstructed view. They allow more fresh air and sunlight in, while doing a better job of keeping out small insects. For casement, awning and venting transom windows, frames are available in white, stone or gold dust as well as all interior painted options, six wood veneers and six stain colors to match the interior finish. Insect screens for double-hung windows are installed on the exterior of the window and frames match product exterior.

**GRILLES**

Grilles are available in a variety of configurations and widths. See page 15 for details.

**EXTERIOR TRIM**

This product is available with Andersen Exterior Trim. See pages 141-147 for details.

Lighthouse indicates differences from standard unit or optional upgrades.

\*Actual wood species is either Sapele or Sipo, both non-endangered species grown in Africa, with color and characteristics similar to Central American mahogonies.

\*\*Visit [andersenwindows.com/warranty](http://andersenwindows.com/warranty) for details.

Dimensions in parentheses are in millimeters.

## Table of Casement Window Sizes

Scale 1/8" (3) = 1'-0" (305) – 1:96

Notes on the next page also apply to this page.

Window Dimension	1'-7 1/4"	1'-11 1/4"	2'-3 1/4"	2'-5 1/4"	2'-7 1/4"	2'-9 1/4"	2'-11 1/4"	3'-1 1/4"	3'-3 1/4"	3'-5 1/4"	3'-7 1/4"	3'-9 1/4"	3'-11 1/4"
	(489)	(591)	(692)	(743)	(794)	(845)	(895)	(946)	(997)	(1048)	(1099)	(1149)	(1200)
<b>Minimum Rough Opening</b>	1'-8"	2'-0"	2'-4"	2'-6"	2'-8"	2'-10"	3'-0"	3'-2"	3'-4"	3'-6"	3'-8"	3'-10"	4'-0"
	(508)	(610)	(711)	(762)	(813)	(864)	(914)	(965)	(1016)	(1067)	(1118)	(1168)	(1219)
Unobstructed Glass	12 5/8"	16 5/8"	20 5/8"	22 5/8"	24 5/8"	26 5/8"	28 5/8"	30 5/8"	32 5/8"	34 5/8"	36 5/8"	38 5/8"	40 5/8"
	(320)	(422)	(523)	(574)	(625)	(676)	(726)	(777)	(828)	(879)	(930)	(980)	(1031)

### CUSTOM SIZES AVAILABLE

Window Dimension	CUSTOM SIZES AVAILABLE													
2'-3 1/4"														
	ACW1824	ACW2024	ACW2424	ACW2624	ACW2824									
2'-7 1/4"														
	ACW1828	ACW2028	ACW2428	ACW2628	ACW2828	ACW21028	ACW3028							
2'-11 1/4"														
	ACW1830	ACW2030	ACW2430	ACW2630	ACW2830	ACW21030	ACW3030	ACW3230*	ACW3430*					
3'-3 1/4"														
	ACW1834	ACW2034	ACW2434	ACW2634	ACW2834	ACW21034	ACW3034	ACW3234*	ACW3434*	ACW3634**	ACW3834**			
3'-7 1/4"														
	ACW1838	ACW2038	ACW2438	ACW2638*	ACW2838*	ACW21038*	ACW3038*	ACW3238*	ACW3438**	ACW3638**	ACW3838**	ACW31038**	ACW4038**	
3'-11 1/4"														
	ACW1840	ACW2040	ACW2440*	ACW2640*	ACW2840*	ACW21040*	ACW3040*	ACW3240*	ACW3440**	ACW3640**	ACW3840**	ACW31040**	ACW4040**	
4'-3 1/4"														
	ACW1844	ACW2044	ACW2444*	ACW2644*	ACW2844*	ACW21044*	ACW3044*	ACW3244*	ACW3444**	ACW3644**	ACW3844**	ACW31044**	ACW4044**	
4'-7 1/4"														
	ACW1848	ACW2048	ACW2448*	ACW2648*	ACW2848*	ACW21048*	ACW3048*	ACW3248*	ACW3448**	ACW3648**	ACW3848**	ACW31048**	ACW4048**	
4'-11 1/4"														
	ACW1850	ACW2050	ACW2450*	ACW2650*	ACW2850*	ACW21050*	ACW3050*	ACW3250*	ACW3450**	ACW3650**	ACW3850**	ACW31050**	ACW4050**	
5'-3 1/4"														
	ACW1854	ACW2054	ACW2454*	ACW2654*	ACW2854*	ACW21054*	ACW3054*	ACW3254*	ACW3454**	ACW3654**	ACW3854**	ACW31054**	ACW4054**	
5'-7 1/4"														
	ACW1858	ACW2058	ACW2458*	ACW2658*	ACW2858*	ACW21058*	ACW3058*	ACW3258*	ACW3458**	ACW3658**	ACW3858**	ACW31058**	ACW4058**	

continued on next page

\*"Window Dimension" always refers to outside frame to frame dimension.

\*\*"Minimum Rough Opening" dimensions may need to be increased to allow for use of building wraps, flashing, sill panning, brackets, fasteners or other items. See installation information on page 170.

• Dimensions in parentheses are in millimeters.

◊Meet or exceed clear opening area of 5.7 sq. ft. or 0.53 m<sup>2</sup>, clear opening width of 20" (508) and clear opening height of 24" (610). See tables on pages 26-29.

\*Hinged for widest clear opening. All other sizes have hinge with wash mode only.

†Engaged control bracket restricts opening to 72 degrees. Control bracket can be disengaged to allow sash to open to 90 degrees.

‡Operator track stop restricts opening between 31 and 52 degrees. Operator track stop cannot be disengaged.

**Table of Casement Window Sizes** (continued)

Notes on the previous page also apply to this page.

Scale 1/8" (3) = 1'-0" (305) – 1:96

Window Dimension	1'-7 1/4" (489)	1'-11 1/4" (591)	2'-3 1/4" (692)	2'-5 1/4" (743)	2'-7 1/4" (794)	2'-9 1/4" (845)	2'-11 1/4" (895)	3'-1 1/4" (946)	3'-3 1/4" (997)	3'-5 1/4" (1048)	3'-7 1/4" (1099)	3'-9 1/4" (1149)	3'-11 1/4" (1200)
<b>Minimum Rough Opening</b>	1'-8" (508)	2'-0" (610)	2'-4" (711)	2'-6" (762)	2'-8" (813)	2'-10" (864)	3'-0" (914)	3'-2" (965)	3'-4" (1016)	3'-6" (1067)	3'-8" (1118)	3'-10" (1168)	4'-0" (1219)
Unobstructed Glass	12 5/8" (320)	16 5/8" (422)	20 5/8" (523)	22 5/8" (574)	24 5/8" (625)	26 5/8" (676)	28 5/8" (726)	30 5/8" (777)	32 5/8" (828)	34 5/8" (890)	36 5/8" (930)	38 5/8" (1031)	40 5/8" (1234)

**CUSTOM SIZES AVAILABLE**

Window Dimension	ACW1860	ACW2060	ACW2460 <sup>0*</sup>	ACW2660 <sup>0*</sup>	ACW2860 <sup>0*</sup>	ACW21060 <sup>0*</sup>	ACW3060 <sup>0*</sup>	ACW3260 <sup>0**</sup>	ACW3460 <sup>0**</sup>	ACW3660 <sup>0**</sup>	ACW3860 <sup>0**</sup>	ACW31060 <sup>0**</sup>	ACW4060 <sup>0**</sup>
5'-11 1/4" (1810)													
6'-3 1/4" (1911)	ACW1864 <sup>†</sup>	ACW2064 <sup>†</sup>	ACW2464 <sup>0*</sup>	ACW2664 <sup>0*</sup>	ACW2864 <sup>0**</sup>	ACW21064 <sup>0**</sup>	ACW3064 <sup>0**</sup>	ACW3264 <sup>0**</sup>	ACW3464 <sup>0**</sup>	ACW3664 <sup>0**</sup>	ACW3864 <sup>0**</sup>	ACW31064 <sup>0**</sup>	ACW4064 <sup>0**</sup>
6'-7 1/4" (2013)	ACW1868 <sup>†</sup>	ACW2068 <sup>†</sup>	ACW2468 <sup>0*</sup>	ACW2668 <sup>0*</sup>	ACW2868 <sup>0**</sup>	ACW21068 <sup>0**</sup>	ACW3068 <sup>0**</sup>	ACW3268 <sup>0**</sup>	ACW3468 <sup>0**</sup>	ACW3668 <sup>0**</sup>	ACW3868 <sup>0**</sup>	ACW31068 <sup>0**</sup>	ACW4068 <sup>0**</sup>
6'-11 1/4" (2115)	ACW1870 <sup>†</sup>	ACW2070 <sup>†</sup>	ACW2470 <sup>0*</sup>	ACW2670 <sup>0*</sup>	ACW2870 <sup>0**</sup>	ACW21070 <sup>0**</sup>	ACW3070 <sup>0**</sup>	ACW3270 <sup>0**</sup>	ACW3470 <sup>0**</sup>	ACW3670 <sup>0**</sup>	ACW3870 <sup>0**</sup>	ACW31070 <sup>0**</sup>	
7'-3 1/4" (2216)	ACW1874 <sup>†</sup>	ACW2074 <sup>†</sup>	ACW2474 <sup>0*</sup>	ACW2674 <sup>0*</sup>	ACW2874 <sup>0**</sup>	ACW21074 <sup>0**</sup>	ACW3074 <sup>0**</sup>	ACW3274 <sup>0**</sup>	ACW3474 <sup>0**</sup>	ACW3674 <sup>0**</sup>	ACW3874 <sup>0**</sup>	ACW31074 <sup>0**</sup>	
7'-7 1/4" (2318)	ACW1878 <sup>†</sup>	ACW2078 <sup>†</sup>	ACW2478 <sup>0*</sup>	ACW2678 <sup>0*</sup>	ACW2878 <sup>0**</sup>	ACW21078 <sup>0**</sup>	ACW3078 <sup>0**</sup>	ACW3278 <sup>0**</sup>	ACW3478 <sup>0**</sup>	ACW3678 <sup>0**</sup>			
7'-11 1/4" (2419)	ACW1880 <sup>†</sup>	ACW2080 <sup>†</sup>	ACW2480 <sup>0*</sup>	ACW2680 <sup>0*</sup>	ACW2880 <sup>0**</sup>	ACW21080 <sup>0**</sup>	ACW3080 <sup>0**</sup>	ACW3280 <sup>0**</sup>	ACW3480 <sup>0**</sup>	ACW3680 <sup>0**</sup>			

Custom-size windows are available in 1/8" (3) increments. See page 60 for custom sizes and specifications.

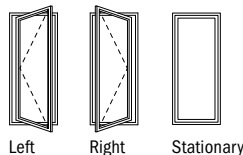

Choose left, right or stationary as viewed from the exterior. Details shown on page 29. Grille patterns shown on page 35.

**Casement Window Opening and Area Specifications**

Window Number	Clear Opening in Full Open Position			Glass Area Sq. Ft./ (m <sup>2</sup> )	Vent Sq. Ft./ (m <sup>2</sup> )	Top of Subfloor to Top of Inside Sill Stop Inches/ (mm)	Overall Window Area Sq. Ft./ (m <sup>2</sup> )
	Clear Opening Sq. Ft./ (m <sup>2</sup> )	Width Inches/ (mm)	Height Inches/ (mm)				
ACW1824	1.48 (0.14)	9 13/16" (250)	21 5/8" (549)	1.73 (0.16)	1.91 (0.18)	58 1/16" (1475)	3.64 (0.34)
ACW1828	1.75 (0.16)	9 13/16" (250)	25 5/8" (650)	2.08 (0.19)	2.26 (0.21)	54 1/16" (1373)	4.18 (0.39)
ACW1830	2.02 (0.19)	9 13/16" (250)	29 5/8" (752)	2.43 (0.23)	2.61 (0.24)	50 1/16" (1271)	4.71 (0.44)
ACW1834	2.29 (0.21)	9 13/16" (250)	33 5/8" (853)	2.78 (0.26)	2.97 (0.28)	46 1/16" (1170)	5.25 (0.49)
ACW1838	2.57 (0.24)	9 13/16" (250)	37 5/8" (955)	3.13 (0.29)	3.32 (0.31)	42 1/16" (1068)	5.78 (0.54)
ACW1840	2.84 (0.26)	9 13/16" (250)	41 5/8" (1057)	3.48 (0.32)	3.67 (0.34)	38 1/16" (967)	6.32 (0.59)
ACW1844	3.11 (0.29)	9 13/16" (250)	45 5/8" (1159)	3.83 (0.36)	4.03 (0.37)	34 1/16" (865)	6.85 (0.64)
ACW1848	3.39 (0.31)	9 13/16" (250)	49 5/8" (1260)	4.18 (0.39)	4.38 (0.41)	30 1/16" (763)	7.39 (0.69)
ACW1850	3.66 (0.34)	9 13/16" (250)	53 5/8" (1362)	4.53 (0.42)	4.73 (0.44)	26 1/16" (662)	7.92 (0.74)
ACW1854	3.93 (0.37)	9 13/16" (250)	57 5/8" (1464)	4.88 (0.45)	5.09 (0.47)	22 1/16" (560)	8.46 (0.79)
ACW1858	3.55 (0.33)	8 5/16" (211)	61 5/8" (1565)	5.23 (0.49)	5.44 (0.51)	18 1/16" (459)	8.99 (0.84)
ACW1860	3.78 (0.35)	8 5/16" (211)	65 5/8" (1667)	5.58 (0.52)	5.79 (0.54)	14 1/16" (357)	9.52 (0.88)
ACW1864†	4.68 (0.43)	9 11/16" (246)	69 5/8" (1768)	5.93 (0.55)	6.15 (0.57)	10 1/16" (256)	10.06 (0.93)
ACW1868†	4.95 (0.46)	9 11/16" (246)	73 5/8" (1870)	6.28 (0.58)	6.50 (0.60)	6 1/16" (154)	10.59 (0.98)
ACW1870†	5.22 (0.48)	9 11/16" (246)	77 5/8" (1972)	6.63 (0.62)	6.85 (0.64)	15 9/16" (395)	11.13 (1.03)
ACW1874†	5.49 (0.51)	9 11/16" (246)	81 5/8" (2073)	6.98 (0.65)	7.20 (0.67)	11 9/16" (294)	11.66 (1.08)
ACW1878†	5.76 (0.54)	9 11/16" (246)	85 5/8" (2175)	7.33 (0.68)	7.56 (0.70)	7 9/16" (192)	12.20 (1.13)
ACW1880†	6.03 (0.56)	9 11/16" (246)	89 5/8" (2276)	7.68 (0.71)	7.91 (0.73)	3 9/16" (90)	12.73 (1.18)
ACW2024	2.08 (0.19)	13 13/16" (351)	21 5/8" (549)	2.28 (0.21)	2.51 (0.23)	58 1/16" (1475)	4.40 (0.41)
ACW2028	2.46 (0.23)	13 13/16" (351)	25 5/8" (650)	2.74 (0.25)	2.97 (0.28)	54 1/16" (1373)	5.05 (0.47)
ACW2030	2.84 (0.26)	13 13/16" (351)	29 5/8" (752)	3.20 (0.30)	3.44 (0.32)	50 1/16" (1271)	5.69 (0.53)
ACW2034	3.23 (0.30)	13 13/16" (351)	33 5/8" (853)	3.67 (0.34)	3.90 (0.36)	46 1/16" (1170)	6.34 (0.59)
ACW2038	3.61 (0.34)	13 13/16" (351)	37 5/8" (955)	4.13 (0.38)	4.36 (0.41)	42 1/16" (1068)	6.98 (0.65)
ACW2040	4.00 (0.37)	13 13/16" (351)	41 5/8" (1057)	4.59 (0.43)	4.83 (0.45)	38 1/16" (967)	7.63 (0.71)
ACW2044	4.38 (0.41)	13 13/16" (351)	45 5/8" (1159)	5.05 (0.47)	5.29 (0.49)	34 1/16" (865)	8.27 (0.77)
ACW2048	4.24 (0.39)	12 5/16" (313)	49 5/8" (1260)	5.51 (0.51)	5.76 (0.54)	30 1/16" (763)	8.92 (0.83)
ACW2050	4.58 (0.43)	12 5/16" (313)	53 5/8" (1362)	5.97 (0.55)	6.22 (0.58)	26 1/16" (662)	9.57 (0.89)
ACW2054	4.92 (0.46)	12 5/16" (313)	57 5/8" (1464)	6.43 (0.60)	6.69 (0.62)	22 1/16" (560)	10.21 (0.95)
ACW2058	5.26 (0.49)	12 5/16" (313)	61 5/8" (1565)	6.89 (0.64)	7.15 (0.66)	18 1/16" (459)	10.86 (1.01)
ACW2060†	5.61 (0.52)	12 5/16" (313)	65 5/8" (1667)	7.35 (0.68)	7.61 (0.71)	14 1/16" (357)	11.50 (1.07)
ACW2064†	6.52 (0.61)	13 1/2" (343)	69 5/8" (1768)	7.82 (0.73)	8.08 (0.75)	10 1/16" (256)	12.15 (1.13)
ACW2068†	6.89 (0.64)	13 1/2" (343)	73 5/8" (1870)	8.28 (0.77)	8.54 (0.79)	6 1/16" (154)	12.80 (1.19)
ACW2070†	7.27 (0.68)	13 1/2" (343)	77 5/8" (1972)	8.74 (0.81)	9.01 (0.84)	15 9/16" (395)	13.44 (1.25)
ACW2074	7.64 (0.71)	13 1/2" (343)	81 5/8" (2073)	9.20 (0.85)	9.47 (0.88)	11 9/16" (294)	14.09 (1.31)
ACW2078†	8.02 (0.75)	13 1/2" (343)	85 5/8" (2175)	9.66 (0.90)	9.94 (0.92)	7 9/16" (192)	14.73 (1.37)
ACW2080†	8.39 (0.78)	13 1/2" (343)	89 5/8" (2276)	10.12 (0.94)	10.40 (0.97)	3 9/16" (90)	15.38 (1.43)
ACW2424	2.45 (0.23)	16 5/16" (414)	21 5/8" (549)	2.83 (0.26)	3.11 (0.29)	58 1/16" (1475)	5.16 (0.48)
ACW2428	2.90 (0.27)	16 5/16" (414)	25 5/8" (650)	3.40 (0.32)	3.68 (0.34)	54 1/16" (1373)	5.91 (0.55)
ACW2430	3.35 (0.31)	16 5/16" (414)	29 5/8" (752)	3.98 (0.37)	4.28 (0.40)	50 1/16" (1271)	6.67 (0.62)
ACW2434	3.80 (0.35)	16 5/16" (414)	33 5/8" (853)	4.55 (0.42)	4.83 (0.45)	46 1/16" (1170)	7.43 (0.69)
ACW2438	4.26 (0.40)	16 5/16" (414)	37 5/8" (955)	5.12 (0.48)	5.41 (0.50)	42 1/16" (1068)	8.18 (0.76)
ACW2440 ◊*	5.92 (0.55)	20 1/2" (521)	41 5/8" (1057)	5.69 (0.53)	5.98 (0.56)	38 1/16" (967)	8.94 (0.83)
ACW2444 ◊*	6.49 (0.60)	20 1/2" (521)	45 5/8" (1159)	6.27 (0.58)	6.56 (0.61)	34 1/16" (865)	9.70 (0.90)
ACW2448 ◊*	7.06 (0.66)	20 1/2" (521)	49 5/8" (1260)	6.84 (0.64)	7.13 (0.66)	30 1/16" (763)	10.46 (0.97)
ACW2450 ◊*	7.63 (0.71)	20 1/2" (521)	53 5/8" (1362)	7.41 (0.69)	7.71 (0.72)	26 1/16" (662)	11.21 (1.04)
ACW2454 ◊*	8.20 (0.76)	20 1/2" (521)	57 5/8" (1464)	7.98 (0.74)	8.29 (0.77)	22 1/16" (560)	11.97 (1.11)
ACW2458 ◊*	8.77 (0.81)	20 1/2" (521)	61 5/8" (1565)	8.55 (0.79)	8.86 (0.82)	18 1/16" (459)	12.73 (1.18)
ACW2460 ◊*	9.34 (0.87)	20 1/2" (521)	65 5/8" (1667)	9.13 (0.85)	9.44 (0.88)	14 1/16" (357)	13.48 (1.25)
ACW2464 ◊*	9.95 (0.92)	20 5/8" (524)	69 5/8" (1768)	9.70 (0.90)	10.01 (0.93)	10 1/16" (256)	14.24 (1.32)
ACW2468 ◊*	10.52 (0.98)	20 5/8" (524)	73 5/8" (1870)	10.27 (0.95)	10.59 (0.98)	6 1/16" (154)	15.00 (1.39)
ACW2470 ◊*	11.09 (1.03)	20 5/8" (524)	77 5/8" (1972)	10.84 (1.01)	11.16 (1.04)	15 9/16" (395)	15.75 (1.46)
ACW2474 ◊*	11.66 (1.08)	20 5/8" (524)	81 5/8" (2073)	11.42 (1.06)	11.74 (1.09)	11 9/16" (294)	16.51 (1.53)
ACW2478 ◊*	12.23 (1.14)	20 5/8" (524)	85 5/8" (2175)	11.99 (1.11)	12.31 (1.14)	7 9/16" (192)	17.27 (1.60)
ACW2480 ◊*	12.80 (1.19)	20 5/8" (524)	89 5/8" (2276)	12.56 (1.17)	12.89 (1.20)	3 9/16" (90)	18.02 (1.67)
ACW2624	2.75 (0.26)	18 5/16" (465)	21 5/8" (549)	3.11 (0.29)	3.41 (0.32)	58 1/16" (1475)	5.54 (0.51)
ACW2628	3.25 (0.30)	18 5/16" (465)	25 5/8" (650)	3.74 (0.35)	4.04 (0.38)	54 1/16" (1373)	6.35 (0.59)
ACW2630	3.76 (0.35)	18 5/16" (465)	29 5/8" (752)	4.36 (0.41)	4.67 (0.43)	50 1/16" (1271)	7.16 (0.67)
ACW2634	4.27 (0.40)	18 5/16" (465)	33 5/8" (853)	4.99 (0.46)	5.30 (0.49)	46 1/16" (1170)	7.97 (0.74)
ACW2638 ◊*	5.88 (0.55)	22 1/2" (572)	37 5/8" (955)	5.62 (0.52)	5.93 (0.55)	42 1/16" (1068)	8.79 (0.82)
ACW2640 ◊*	6.50 (0.60)	22 1/2" (572)	41 5/8" (1057)	6.25 (0.58)	6.56 (0.61)	38 1/16" (967)	9.60 (0.89)
ACW2644 ◊*	7.13 (0.66)	22 1/2" (572)	45 5/8" (1159)	6.87 (0.64)	7.19 (0.67)	34 1/16" (865)	10.41 (0.97)

\* "Top of Subfloor to Top of Inside Sill Stop" is calculated based upon a structural header height of 6'-10 1/2" (2096) except for units greater than 81 3/4" (2076) in height which are calculated using a header height of 8' (2438).  
 ◊ Meet or exceed clear opening area of 5.7 sq. ft. or 0.53 m<sup>2</sup>, clear opening width of 20" (508) and clear opening height of 24" (610).  
 † Hinged for widest clear opening. All other sizes have hinge with wash mode only.

continued on next page

Casement Window Opening and Area Specifications *(continued)*

Window Number	Clear Opening Sq. Ft./ (m <sup>2</sup> )		Clear Opening in Full Open Position		Glass Area Sq. Ft./ (m <sup>2</sup> )	Vent Sq. Ft./ (m <sup>2</sup> )	Top of Subfloor to Top of Inside Sill Stop Inches/(mm)		Overall Window Area Sq. Ft./ (m <sup>2</sup> )
			Width Inches/(mm)	Height Inches/(mm)					
ACW2648 0*	7.75	(0.72)	22 1/2" (572)	49 5/8" (1260)	7.50 (0.70)	7.82 (0.73)	30 1/16" (763)	11.22 (1.04)	
ACW2650 0*	8.38	(0.78)	22 1/2" (572)	53 5/8" (1362)	8.13 (0.76)	8.45 (0.79)	26 1/16" (662)	12.04 (1.12)	
ACW2654 0*	9.01	(0.84)	22 1/2" (572)	57 5/8" (1464)	8.76 (0.81)	9.09 (0.84)	22 1/16" (560)	12.85 (1.19)	
ACW2658 0*	9.63	(0.89)	22 1/2" (572)	61 5/8" (1565)	9.39 (0.87)	9.72 (0.90)	18 1/16" (459)	13.66 (1.27)	
ACW2660 0*	10.26	(0.95)	22 1/2" (572)	65 5/8" (1667)	10.01 (0.93)	10.35 (0.96)	14 1/16" (357)	14.47 (1.34)	
ACW2664 0*	10.91	(1.01)	22 5/8" (575)	69 5/8" (1768)	10.64 (0.99)	10.98 (1.02)	10 1/16" (256)	15.29 (1.42)	
ACW2668 0*	11.54	(1.07)	22 5/8" (575)	73 5/8" (1870)	11.27 (1.05)	11.61 (1.08)	6 1/16" (154)	16.10 (1.50)	
ACW2670 0*	12.17	(1.13)	22 5/8" (575)	77 5/8" (1972)	11.90 (1.11)	12.24 (1.14)	15 9/16" (395)	16.91 (1.57)	
ACW2674 0*	12.79	(1.19)	22 5/8" (575)	81 5/8" (2073)	12.52 (1.16)	12.87 (1.20)	11 9/16" (294)	17.72 (1.65)	
ACW2678 0*	13.42	(1.25)	22 5/8" (575)	85 5/8" (2175)	13.15 (1.22)	13.50 (1.25)	7 9/16" (192)	18.54 (1.72)	
ACW2680 0*	14.05	(1.31)	22 5/8" (575)	89 5/8" (2276)	13.78 (1.28)	14.13 (1.31)	3 9/16" (90)	19.35 (1.80)	
ACW2824	3.05	(0.28)	20 5/16" (516)	21 5/8" (549)	3.38 (0.31)	3.71 (0.34)	58 1/16" (1475)	5.91 (0.55)	
ACW2828	3.61	(0.34)	20 5/16" (516)	25 5/8" (650)	4.07 (0.38)	4.39 (0.41)	54 1/16" (1373)	6.78 (0.63)	
ACW2830	4.17	(0.39)	20 5/16" (516)	29 5/8" (752)	4.75 (0.44)	5.08 (0.47)	50 1/16" (1271)	7.65 (0.71)	
ACW2834	4.74	(0.44)	20 5/16" (516)	33 5/8" (853)	5.43 (0.50)	5.77 (0.54)	46 1/16" (1170)	8.52 (0.79)	
ACW2838 0*	6.40	(0.59)	24 1/2" (623)	37 5/8" (955)	6.12 (0.57)	6.45 (0.60)	42 1/16" (1068)	9.39 (0.87)	
ACW2840 0	5.87	(0.55)	20 5/16" (516)	41 5/8" (1057)	6.80 (0.63)	7.14 (0.66)	38 1/16" (967)	10.25 (0.95)	
ACW2844 0	6.43	(0.60)	20 5/16" (516)	45 5/8" (1159)	7.48 (0.69)	7.83 (0.73)	34 1/16" (865)	11.12 (1.03)	
ACW2848 0	6.99	(0.65)	20 5/16" (516)	49 5/8" (1260)	8.17 (0.76)	8.51 (0.79)	30 1/16" (763)	11.99 (1.11)	
ACW2850 0	7.56	(0.70)	20 5/16" (516)	53 5/8" (1362)	8.85 (0.82)	9.20 (0.85)	26 1/16" (662)	12.86 (1.19)	
ACW2854 0†	9.44	(0.88)	23 19/32" (599)	57 5/8" (1464)	9.53 (0.89)	9.89 (0.92)	22 1/16" (560)	13.73 (1.28)	
ACW2858 0†	10.09	(0.94)	23 19/32" (599)	61 5/8" (1565)	10.22 (0.95)	10.57 (0.98)	18 1/16" (459)	14.59 (1.36)	
ACW2860 0†	10.75	(1.00)	23 19/32" (599)	65 5/8" (1667)	10.90 (1.01)	11.26 (1.05)	14 1/16" (357)	15.46 (1.44)	
ACW2864 0**	9.95	(0.92)	20 9/16" (522)	69 5/8" (1768)	11.58 (1.08)	11.95 (1.11)	10 1/16" (256)	16.33 (1.52)	
ACW2868 0**	10.52	(0.98)	20 9/16" (522)	73 5/8" (1870)	12.27 (1.14)	12.63 (1.17)	6 1/16" (154)	17.20 (1.60)	
ACW2870 0**	11.09	(1.03)	20 9/16" (522)	77 5/8" (1972)	12.95 (1.20)	13.32 (1.24)	15 9/16" (395)	18.07 (1.68)	
ACW2874 0**	11.66	(1.08)	20 9/16" (522)	81 5/8" (2073)	13.63 (1.27)	14.00 (1.30)	11 9/16" (294)	18.93 (1.76)	
ACW2878 0**	12.23	(1.14)	20 9/16" (522)	85 5/8" (2175)	14.32 (1.33)	14.69 (1.36)	7 9/16" (192)	19.80 (1.84)	
ACW2880 0**	12.81	(1.19)	20 9/16" (522)	89 5/8" (2276)	15.00 (1.39)	15.38 (1.43)	3 9/16" (90)	20.67 (1.92)	
ACW21028	3.97	(0.37)	22 5/16" (567)	25 5/8" (650)	4.40 (0.41)	4.75 (0.44)	54 1/16" (1373)	7.22 (0.67)	
ACW21030	4.58	(0.43)	22 5/16" (567)	29 5/8" (752)	5.14 (0.48)	5.49 (0.51)	50 1/16" (1271)	8.14 (0.76)	
ACW21034	5.20	(0.48)	22 5/16" (567)	33 5/8" (853)	5.87 (0.55)	6.23 (0.58)	46 1/16" (1170)	9.06 (0.84)	
ACW21038 0	5.82	(0.54)	22 5/16" (567)	37 5/8" (955)	6.61 (0.61)	6.98 (0.65)	42 1/16" (1068)	9.99 (0.93)	
ACW21040 0	6.44	(0.60)	22 5/16" (567)	41 5/8" (1057)	7.35 (0.68)	7.72 (0.72)	38 1/16" (967)	10.91 (1.01)	
ACW21044 0	7.06	(0.66)	22 5/16" (567)	45 5/8" (1159)	8.09 (0.75)	8.46 (0.79)	34 1/16" (865)	11.83 (1.10)	
ACW21048 0†	8.78	(0.82)	25 1/2" (648)	49 5/8" (1260)	8.83 (0.82)	9.20 (0.85)	30 1/16" (763)	12.76 (1.19)	
ACW21050 0†	9.49	(0.88)	25 1/2" (648)	53 5/8" (1362)	9.57 (0.89)	9.94 (0.92)	26 1/16" (662)	13.68 (1.27)	
ACW21054 0†	10.20	(0.95)	25 1/2" (648)	57 5/8" (1464)	10.31 (0.96)	10.69 (0.99)	22 1/16" (560)	14.60 (1.36)	
ACW21058 0†	10.91	(1.01)	25 1/2" (648)	61 5/8" (1565)	11.05 (1.03)	11.43 (1.06)	18 1/16" (459)	15.53 (1.44)	
ACW21060 0†	11.61	(1.08)	25 1/2" (648)	65 5/8" (1667)	11.79 (1.10)	12.17 (1.13)	14 1/16" (357)	16.45 (1.53)	
ACW21064 0**	10.71	(0.99)	22 1/8" (562)	69 5/8" (1768)	12.52 (1.16)	12.91 (1.20)	10 1/16" (256)	17.38 (1.61)	
ACW21068 0**	11.32	(1.05)	22 1/8" (562)	73 5/8" (1870)	13.26 (1.23)	13.65 (1.27)	6 1/16" (154)	18.30 (1.70)	
ACW21070 0**	11.94	(1.11)	22 1/8" (562)	77 5/8" (1972)	14.00 (1.30)	14.40 (1.34)	15 9/16" (395)	19.22 (1.79)	
ACW21074 0**	12.56	(1.17)	22 1/8" (562)	81 5/8" (2073)	14.74 (1.37)	15.14 (1.41)	11 9/16" (294)	20.15 (1.87)	
ACW21078 0**	13.17	(1.22)	22 1/8" (562)	85 5/8" (2175)	15.48 (1.44)	15.88 (1.48)	7 9/16" (192)	21.07 (1.96)	
ACW21080 0**	13.79	(1.27)	22 1/8" (562)	89 5/8" (2276)	16.22 (1.51)	16.62 (1.55)	3 9/16" (90)	23.32 (2.17)	
ACW3028	4.32	(0.40)	24 5/16" (617)	25 5/8" (650)	4.73 (0.44)	5.10 (0.47)	54 1/16" (1373)	7.65 (0.71)	
ACW3030	5.00	(0.46)	24 5/16" (617)	29 5/8" (752)	5.52 (0.51)	5.90 (0.55)	50 1/16" (1271)	8.63 (0.80)	
ACW3034	5.67	(0.53)	24 5/16" (617)	33 5/8" (853)	6.32 (0.59)	6.70 (0.62)	46 1/16" (1170)	9.61 (0.89)	
ACW3038 0	6.35	(0.59)	24 5/16" (617)	37 5/8" (955)	7.11 (0.66)	7.50 (0.70)	42 1/16" (1068)	10.59 (0.98)	
ACW3040 0†	7.91	(0.73)	27 1/16" (696)	41 5/8" (1057)	7.90 (0.73)	8.30 (0.77)	38 1/16" (967)	11.57 (1.07)	
ACW3044 0†	8.68	(0.81)	27 1/16" (696)	45 5/8" (1159)	8.70 (0.81)	9.09 (0.84)	34 1/16" (865)	12.55 (1.17)	
ACW3048 0†	9.44	(0.88)	27 1/16" (696)	49 5/8" (1260)	9.49 (0.88)	9.89 (0.92)	30 1/16" (763)	13.52 (1.26)	
ACW3050 0†	10.2	(0.95)	27 1/16" (696)	53 5/8" (1362)	10.29 (0.96)	10.69 (0.99)	26 1/16" (662)	14.50 (1.35)	
ACW3054 0†	10.96	(1.02)	27 1/16" (696)	57 5/8" (1464)	11.08 (1.03)	11.49 (1.07)	22 1/16" (560)	15.48 (1.44)	
ACW3058 0†	11.72	(1.09)	27 1/16" (696)	61 5/8" (1565)	11.88 (1.10)	12.28 (1.14)	18 1/16" (459)	16.46 (1.53)	
ACW3060 0†	12.48	(1.16)	27 1/16" (696)	65 5/8" (1667)	12.67 (1.18)	13.08 (1.22)	14 1/16" (357)	17.44 (1.62)	
ACW3064 0**	10.77	(1.00)	22 1/4" (565)	69 5/8" (1768)	13.47 (1.25)	13.88 (1.29)	10 1/16" (256)	18.42 (1.71)	
ACW3068 0**	11.39	(1.06)	22 1/4" (565)	73 5/8" (1870)	14.26 (1.32)	14.68 (1.36)	6 1/16" (154)	19.40 (1.80)	
ACW3070 0**	12.01	(1.12)	22 1/4" (565)	77 5/8" (1972)	15.05 (1.40)	15.47 (1.44)	15 9/16" (395)	20.38 (1.89)	
ACW3074 0**	12.63	(1.17)	22 1/4" (565)	81 5/8" (2073)	15.85 (1.47)	16.27 (1.51)	11 9/16" (294)	21.36 (1.98)	

\*"Top of Subfloor to Top of Inside Sill Stop" is calculated based upon a structural header height of 6'-10 1/2" (2096) except for units greater than 81 3/4" (2076) in height which are calculated using a header height of 8' (2438).

\*Dimensions in parentheses are in millimeters or square meters.

0 Meet or exceed clear opening area of 5.7 sq. ft. or 0.53 m<sup>2</sup>, clear opening width of 20" (508) and clear opening height of 24" (610).

\*Hinged for widest clear opening. All other sizes have hinge with wash mode only.

†Engaged control bracket restricts opening to 72 degrees. Control bracket can be disengaged to allow sash to open to 90 degrees.

‡Operator track stop restricts opening between 31 and 52 degrees. Operator track stop cannot be disengaged.

continued on next page

A-Series Casement & Awning Windows

## Casement Window Opening and Area Specifications (continued)

Window Number	Clear Opening in Full Open Position		Clear Opening Sq. Ft./ <sup>2</sup> (m <sup>2</sup> )	Width Inches/(mm)	Height Inches/(mm)	Glass Area Sq. Ft./ <sup>2</sup> (m <sup>2</sup> )	Vent Sq. Ft./ <sup>2</sup> (m <sup>2</sup> )	Top of Subfloor to Top of Inside Sill Stop Inches/(mm)	Overall Window Area Sq. Ft./ <sup>2</sup> (m <sup>2</sup> )		
										Clear Opening Sq. Ft./ <sup>2</sup> (m <sup>2</sup> )	Width Inches/(mm)
ACW3078 0**	13.25	(1.23)	22 1/4" (565)	85 5/8" (2175)	16.64	(1.55)	17.07	(1.59)	7 9/16" (192)	22.34	(2.08)
ACW3080 0**	13.87	(1.29)	22 1/4" (565)	89 5/8" (2276)	17.44	(1.62)	17.87	(1.66)	3 9/16" (90)	23.32	(2.17)
ACW3230 **	4.78	(0.44)	23 1/4" (591)	29 5/8" (752)	5.91	(0.55)	6.31	(0.59)	50 1/16" (1271)	9.12	(0.85)
ACW3234 **	5.43	(0.50)	23 1/4" (591)	33 5/8" (853)	6.76	(0.63)	7.17	(0.67)	46 1/16" (1170)	10.15	(0.94)
ACW3238 0**	6.07	(0.56)	23 1/4" (591)	37 5/8" (955)	7.61	(0.71)	8.02	(0.75)	42 1/16" (1068)	11.19	(1.04)
ACW3240 0**	6.72	(0.62)	23 1/4" (591)	41 5/8" (1057)	8.46	(0.79)	8.87	(0.82)	38 1/16" (967)	12.22	(1.14)
ACW3244 0**	7.36	(0.68)	23 1/4" (591)	45 5/8" (1159)	9.31	(0.86)	9.73	(0.90)	34 1/16" (865)	13.26	(1.23)
ACW3248 0**	8.01	(0.74)	23 1/4" (591)	49 5/8" (1260)	10.16	(0.94)	10.58	(0.98)	30 1/16" (763)	14.29	(1.33)
ACW3250 0**	8.65	(0.80)	23 1/4" (591)	53 5/8" (1362)	11.01	(1.02)	11.43	(1.06)	26 1/16" (662)	15.33	(1.42)
ACW3254 0**	9.30	(0.86)	23 1/4" (591)	57 5/8" (1464)	11.86	(1.10)	12.29	(1.14)	22 1/16" (560)	16.36	(1.52)
ACW3258 0**	9.95	(0.92)	23 1/4" (591)	61 5/8" (1565)	12.71	(1.18)	13.14	(1.22)	18 1/16" (459)	17.40	(1.62)
ACW3260 0**	10.59	(0.98)	23 1/4" (591)	65 5/8" (1667)	13.56	(1.26)	13.99	(1.30)	14 1/16" (357)	18.43	(1.71)
ACW3264 0**	11.24	(1.04)	23 1/4" (591)	69 5/8" (1768)	14.41	(1.34)	14.85	(1.38)	10 1/16" (256)	19.47	(1.81)
ACW3268 0**	11.88	(1.10)	23 1/4" (591)	73 5/8" (1870)	15.26	(1.42)	15.70	(1.46)	6 1/16" (154)	20.50	(1.90)
ACW3270 0**	12.53	(1.16)	23 1/4" (591)	77 5/8" (1972)	16.11	(1.50)	16.55	(1.54)	15 9/16" (395)	21.54	(2.00)
ACW3274 0**	13.18	(1.22)	23 1/4" (591)	81 5/8" (2073)	16.96	(1.58)	17.40	(1.62)	11 9/16" (294)	22.57	(2.10)
ACW3278 0**	13.82	(1.28)	23 1/4" (591)	85 5/8" (2175)	17.81	(1.65)	18.26	(1.70)	7 9/16" (192)	23.60	(2.19)
ACW3280 0**	14.47	(1.34)	23 1/4" (591)	89 5/8" (2276)	18.66	(1.73)	19.11	(1.78)	3 9/16" (90)	24.64	(2.29)
ACW3430 **	4.72	(0.44)	23" (584)	29 5/8" (752)	6.29	(0.58)	6.72	(0.62)	50 1/16" (1271)	9.61	(0.89)
ACW3434 **	5.36	(0.50)	23" (584)	33 5/8" (853)	7.20	(0.67)	7.63	(0.71)	46 1/16" (1170)	10.70	(0.99)
ACW3438 0**	6.00	(0.56)	23" (584)	37 5/8" (955)	8.10	(0.75)	8.54	(0.79)	42 1/16" (1068)	11.79	(1.10)
ACW3440 0**	6.64	(0.62)	23" (584)	41 5/8" (1057)	9.01	(0.84)	9.45	(0.88)	38 1/16" (967)	12.88	(1.20)
ACW3444 0**	7.27	(0.68)	23" (584)	45 5/8" (1159)	9.92	(0.92)	10.36	(0.96)	34 1/16" (865)	13.97	(1.30)
ACW3448 0**	7.91	(0.73)	23" (584)	49 5/8" (1260)	10.82	(1.01)	11.27	(1.05)	30 1/16" (763)	15.06	(1.40)
ACW3450 0**	8.55	(0.79)	23" (584)	53 5/8" (1362)	11.73	(1.09)	12.18	(1.13)	26 1/16" (662)	16.15	(1.50)
ACW3454 0**	9.19	(0.85)	23" (584)	57 5/8" (1464)	12.63	(1.17)	13.09	(1.22)	22 1/16" (560)	17.24	(1.60)
ACW3458 0**	9.83	(0.91)	23" (584)	61 5/8" (1565)	13.54	(1.26)	13.99	(1.30)	18 1/16" (459)	18.33	(1.70)
ACW3460 0**	10.46	(0.97)	23" (584)	65 5/8" (1667)	14.44	(1.34)	14.90	(1.38)	14 1/16" (357)	19.42	(1.80)
ACW3464 0**	11.10	(1.03)	23" (584)	69 5/8" (1768)	15.35	(1.43)	15.81	(1.47)	10 1/16" (256)	20.51	(1.91)
ACW3468 0**	11.74	(1.09)	23" (584)	73 5/8" (1870)	16.25	(1.51)	16.72	(1.55)	6 1/16" (154)	21.60	(2.01)
ACW3470 0**	12.38	(1.15)	23" (584)	77 5/8" (1972)	17.16	(1.59)	17.63	(1.64)	15 9/16" (395)	22.69	(2.11)
ACW3474 0**	13.02	(1.21)	23" (584)	81 5/8" (2073)	18.07	(1.68)	18.54	(1.72)	11 9/16" (294)	23.78	(2.21)
ACW3478 0**	13.66	(1.27)	23" (584)	85 5/8" (2175)	18.97	(1.76)	19.45	(1.81)	7 9/16" (192)	24.87	(2.31)
ACW3480 0**	14.29	(1.33)	23" (584)	89 5/8" (2276)	19.88	(1.85)	20.36	(1.89)	3 9/16" (90)	25.96	(2.41)
ACW3634 **	5.27	(0.49)	22 9/16" (573)	33 5/8" (853)	7.64	(0.71)	8.10	(0.75)	46 1/16" (1170)	11.24	(1.04)
ACW3638 0**	5.90	(0.55)	22 9/16" (573)	37 5/8" (955)	8.60	(0.80)	9.06	(0.84)	42 1/16" (1068)	12.39	(1.15)
ACW3640**	6.53	(0.61)	22 9/16" (573)	41 5/8" (1057)	9.56	(0.89)	10.03	(0.93)	38 1/16" (967)	13.54	(1.26)
ACW3644 0**	7.15	(0.66)	22 9/16" (573)	45 5/8" (1159)	10.52	(0.98)	10.99	(1.02)	34 1/16" (865)	14.68	(1.36)
ACW3648 0**	7.78	(0.72)	22 9/16" (573)	49 5/8" (1260)	11.49	(1.07)	11.96	(1.11)	30 1/16" (763)	15.83	(1.47)
ACW3650 0**	8.41	(0.78)	22 9/16" (573)	53 5/8" (1362)	12.45	(1.16)	12.92	(1.20)	26 1/16" (662)	16.97	(1.58)
ACW3654 0**	9.03	(0.84)	22 9/16" (573)	57 5/8" (1464)	13.41	(1.25)	13.89	(1.29)	22 1/16" (560)	18.12	(1.68)
ACW3658 0**	9.66	(0.90)	22 9/16" (573)	61 5/8" (1565)	14.37	(1.34)	14.85	(1.38)	18 1/16" (459)	19.26	(1.79)
ACW3660 0**	10.29	(0.96)	22 9/16" (573)	65 5/8" (1667)	15.33	(1.42)	15.81	(1.47)	14 1/16" (357)	20.41	(1.90)
ACW3664 0**	10.92	(1.01)	22 9/16" (573)	69 5/8" (1768)	16.29	(1.51)	16.78	(1.56)	10 1/16" (256)	21.56	(2.00)
ACW3668 0**	11.54	(1.07)	22 9/16" (573)	73 5/8" (1870)	17.25	(1.60)	17.74	(1.65)	6 1/16" (154)	22.70	(2.11)
ACW3670 0**	12.17	(1.13)	22 9/16" (573)	77 5/8" (1972)	18.21	(1.69)	18.71	(1.74)	15 9/16" (395)	23.85	(2.22)
ACW3678 0**	13.43	(1.25)	22 9/16" (573)	85 5/8" (2175)	20.14	(1.87)	20.64	(1.92)	7 9/16" (192)	26.14	(2.43)
ACW3680 0**	14.05	(1.31)	22 9/16" (573)	89 5/8" (2276)	21.10	(1.96)	21.60	(2.01)	3 9/16" (90)	27.29	(2.54)
ACW3674 0**	12.80	(1.19)	22 9/16" (573)	81 5/8" (2073)	19.17	(1.78)	19.67	(1.83)	11 9/16" (294)	24.99	(2.32)
ACW3834 **	5.18	(0.48)	22 1/4" (565)	33 5/8" (853)	8.08	(0.75)	8.57	(0.80)	46 1/16" (1170)	11.79	(1.10)
ACW3838 0**	5.80	(0.54)	22 1/4" (565)	37 5/8" (955)	9.10	(0.85)	9.59	(0.89)	42 1/16" (1068)	12.99	(1.21)
ACW3840 0**	6.42	(0.60)	22 1/4" (565)	41 5/8" (1057)	10.12	(0.94)	10.61	(0.99)	38 1/16" (967)	14.19	(1.32)
ACW3844 0**	7.04	(0.65)	22 1/4" (565)	45 5/8" (1159)	11.13	(1.03)	11.63	(1.08)	34 1/16" (865)	15.39	(1.43)
ACW3848 0**	7.65	(0.71)	22 1/4" (565)	49 5/8" (1260)	12.15	(1.13)	12.65	(1.18)	30 1/16" (763)	16.59	(1.54)
ACW3850 0**	8.27	(0.77)	22 1/4" (565)	53 5/8" (1362)	13.17	(1.22)	13.67	(1.27)	26 1/16" (662)	17.80	(1.65)
ACW3854 0**	8.89	(0.83)	22 1/4" (565)	57 5/8" (1464)	14.18	(1.32)	14.69	(1.36)	22 1/16" (560)	19.00	(1.77)
ACW3858 0**	9.50	(0.88)	22 1/4" (565)	61 5/8" (1565)	15.20	(1.41)	15.71	(1.46)	18 1/16" (459)	20.20	(1.88)
ACW3860 0**	10.12	(0.94)	22 1/4" (565)	65 5/8" (1667)	16.22	(1.51)	16.73	(1.55)	14 1/16" (357)	21.40	(1.99)
ACW3864 0**	10.74	(1.00)	22 1/4" (565)	69 5/8" (1768)	17.23	(1.60)	17.75	(1.65)	10 1/16" (256)	22.60	(2.10)
ACW3868 0**	11.36	(1.06)	22 1/4" (565)	73 5/8" (1870)	18.25	(1.70)	18.76	(1.74)	6 1/16" (154)	23.80	(2.21)
ACW3870 0**	11.97	(1.11)	22 1/4" (565)	77 5/8" (1972)	19.27	(1.79)	19.78	(1.84)	15 9/16" (395)	25.00	(2.32)

\*"Top of Subfloor to Top of Inside Sill Stop" is calculated based upon a structural header height of 6'-10 1/2" (2096) except for units greater than 81 3/4" (2076) in height which are calculated using a header height of 8' (2438).

\*Dimensions in parentheses are in millimeters or square meters.

0Meet or exceed clear opening area of 5.7 sq. ft. or 0.53 m<sup>2</sup>; clear opening width of 20" (508) and clear opening height of 24" (610).

\*\*Hinged for widest clear opening. All other sizes have hinge with wash mode only.

†Engaged control bracket restricts opening to 72 degrees. Control bracket can be disengaged to allow sash to open to 90 degrees.

‡Operator track stop restricts opening between 31 and 52 degrees. Operator track stop cannot be disengaged.

continued on next page

**Caseament Window Opening and Area Specifications** *(continued)*

Window Number	Clear Opening Sq. Ft./ (m <sup>2</sup> )		Clear Opening in Full Open Position		Glass Area Sq. Ft./ (m <sup>2</sup> )	Vent Sq. Ft./ (m <sup>2</sup> )	Top of Subfloor to Top of Inside Sill Stop Inches/ (mm)		Overall Window Area Sq. Ft./ (m <sup>2</sup> )
			Width Inches/ (mm)	Height Inches/ (mm)			Inches/ (mm)	Inches/ (mm)	
ACW3874 $\phi^{**}$	12.59	(1.17)	22 3/4" (565)	81 5/8" (2073)	20.28 (1.88)	20.80 (1.93)	11 9/16" (294)	26.21 (2.43)	
ACW31044 $\phi^{**}$	6.89	(0.64)	21 3/4" (552)	45 5/8" (1159)	11.74 (1.09)	12.26 (1.14)	34 1/16" (865)	16.10 (1.50)	
ACW31048 $\phi^{**}$	7.49	(0.70)	21 3/4" (552)	49 5/8" (1260)	12.81 (1.19)	13.33 (1.24)	30 1/16" (763)	17.36 (1.61)	
ACW31050 $\phi^{**}$	8.09	(0.75)	21 3/4" (552)	53 5/8" (1362)	13.89 (1.29)	14.41 (1.34)	26 1/16" (662)	18.62 (1.73)	
ACW31054 $\phi^{**}$	8.70	(0.81)	21 3/4" (552)	57 5/8" (1464)	14.96 (1.39)	15.49 (1.44)	22 1/16" (560)	19.88 (1.85)	
ACW31058 $\phi^{**}$	9.30	(0.86)	21 3/4" (552)	61 5/8" (1565)	16.03 (1.49)	16.56 (1.54)	18 1/16" (459)	21.13 (1.96)	
ACW31060 $\phi^{**}$	9.91	(0.92)	21 3/4" (552)	65 5/8" (1667)	17.10 (1.59)	17.64 (1.64)	14 1/16" (357)	22.39 (2.08)	
ACW31064 $\phi^{**}$	10.51	(0.98)	21 3/4" (552)	69 5/8" (1768)	18.17 (1.69)	18.71 (1.74)	10 1/16" (256)	23.65 (2.20)	
ACW31068 $\phi^{**}$	11.11	(1.03)	21 3/4" (552)	73 5/8" (1870)	19.25 (1.79)	19.79 (1.84)	6 1/16" (154)	24.90 (2.31)	
ACW31070 $\phi^{**}$	11.72	(1.09)	21 3/4" (552)	77 5/8" (1972)	20.32 (1.89)	20.86 (1.94)	15 9/16" (395)	26.16 (2.43)	
ACW31074 $\phi^{**}$	12.32	(1.14)	21 3/4" (552)	81 5/8" (2073)	21.39 (1.99)	21.94 (2.04)	11 9/16" (294)	27.42 (2.55)	
ACW4038 $\phi^{**}$	5.53	(0.51)	21 3/16" (538)	37 5/8" (955)	10.09 (0.94)	10.63 (0.99)	42 1/16" (1068)	14.19 (1.32)	
ACW4040 $\phi^{**}$	6.12	(0.57)	21 3/16" (538)	41 5/8" (1057)	11.22 (1.04)	11.76 (1.09)	38 1/16" (967)	15.50 (1.44)	
ACW4044 $\phi^{**}$	6.71	(0.62)	21 3/16" (538)	45 5/8" (1159)	12.35 (1.15)	12.89 (1.20)	34 1/16" (865)	16.82 (1.56)	
ACW4048 $\phi^{**}$	7.30	(0.68)	21 3/16" (538)	49 5/8" (1260)	13.48 (1.25)	14.02 (1.30)	30 1/16" (763)	18.13 (1.68)	
ACW4050 $\phi^{**}$	7.89	(0.73)	21 3/16" (538)	53 5/8" (1362)	14.60 (1.36)	15.15 (1.41)	26 1/16" (662)	19.44 (1.81)	
ACW4054 $\phi^{**}$	8.48	(0.79)	21 3/16" (538)	57 5/8" (1464)	15.73 (1.46)	16.29 (1.51)	22 1/16" (560)	20.75 (1.93)	
ACW4058 $\phi^{**}$	9.07	(0.84)	21 3/16" (538)	61 5/8" (1565)	16.86 (1.57)	17.42 (1.62)	18 1/16" (459)	22.07 (2.05)	
ACW4060 $\phi^{**}$	9.66	(0.90)	21 3/16" (538)	65 5/8" (1667)	17.99 (1.67)	18.55 (1.72)	14 1/16" (357)	23.38 (2.17)	
ACW4064 $\phi^{**}$	10.24	(0.95)	21 3/16" (538)	69 5/8" (1768)	19.12 (1.78)	19.68 (1.83)	10 1/16" (256)	24.69 (2.29)	
ACW4068 $\phi^{**}$	10.83	(1.01)	21 3/16" (538)	73 5/8" (1870)	20.24 (1.88)	20.81 (1.93)	6 1/16" (154)	26.00 (2.42)	

\*Top of Subfloor to Top of Inside Sill Stop" is calculated based upon a structural header height of 6'-10 1/2" (2096) except for units greater than 81 3/4" (2076) in height which are calculated using a header height of 8' (2438).  
 \*Dimensions in parentheses are in millimeters or square meters.  
 $\phi$  Meet or exceed clear opening area of 5.7 sq. ft. or 0.53 m<sup>2</sup>, clear opening width of 20" (508) and clear opening height of 24" (610).  
 \*Hinged for widest clear opening. All other sizes have hinge with wash mode only.  
 †Engaged control bracket restricts opening to 72 degrees. Control bracket can be disengaged to allow sash to open to 90 degrees.  
 ‡Operator track stop restricts opening between 31 and 52 degrees. Operator track stop cannot be disengaged.

A-Series Caseament & Awning Windows

**Caseament Window Details**

Scale 1 1/2" (38) = 1'-0" (305) – 1:8

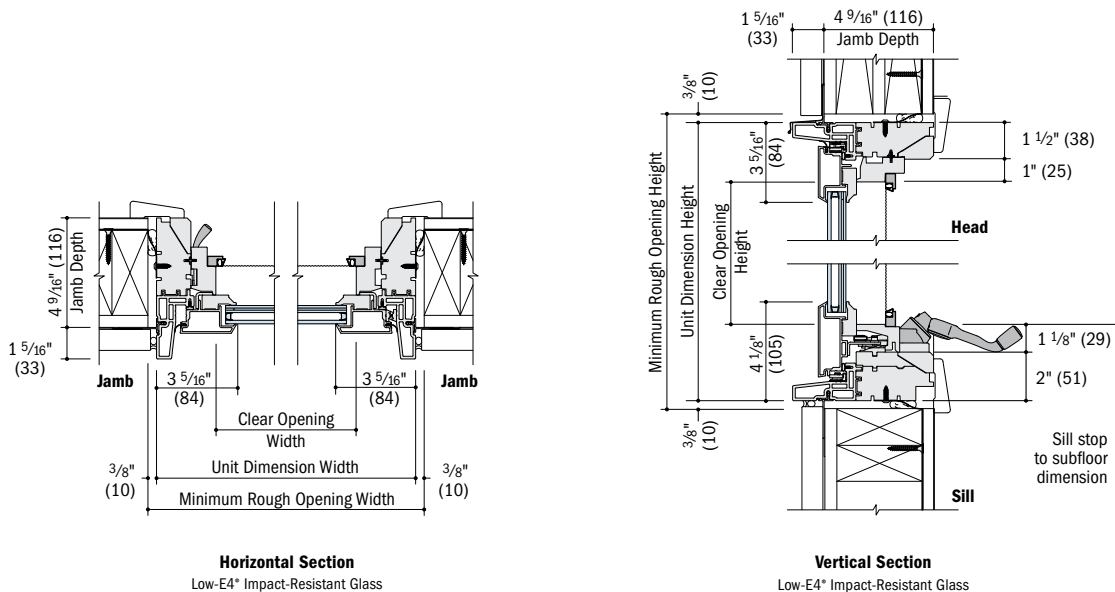











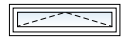
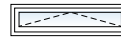
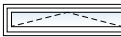
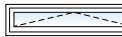
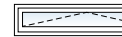









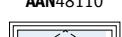
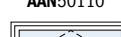
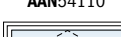

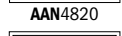

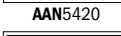
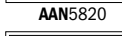

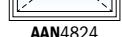

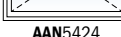
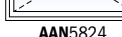

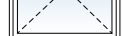
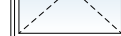

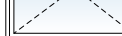
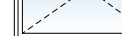
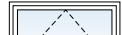
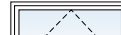
See pages 57-59 for horizontal and vertical joining details.

- 4 9/16" (116) base jamb depth measurement is from back side of installation flange.
- Light-colored areas are parts included with window. Dark-colored areas are additional Andersen® parts required to complete window assembly as shown.
- Dimensions in parentheses are in millimeters.
- Minimum rough opening dimensions may need to be increased to allow for use of building wraps, flashing, sill panning, brackets, fasteners or other items. See installation information on page 170.
- Details are for illustration only and are not intended to represent product installation methods or materials. Refer to product installation guides at andersenwindows.com.

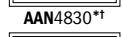

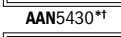
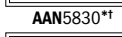

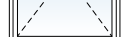
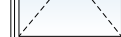
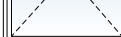
4'-7 1/4" (1403)	4'-11 1/4" (1505)	5'-3 1/4" (1607)	5'-7 1/4" (1708)	5'-11 1/4" (1810)
4'-8" (1422)	5'-0" (1524)	5'-4" (1626)	5'-8" (1727)	6'-0" (1829)
48 5/8" (1234)	52 5/8" (1336)	56 5/8" (1438)	60 5/8" (1539)	64 5/8" (1641)

 AAN4814	 AAN5014	 AAN5414	 AAN5814	 AAN6014
 AAN4818	 AAN5018	 AAN5418	 AAN5818	 AAN6018
 AAN48110	 AAN50110	 AAN54110	 AAN58110	 AAN60110
 AAN4820	 AAN5020	 AAN5420	 AAN5820	 AAN6020
 AAN4824	 AAN5024	 AAN5424	 AAN5824	 AAN6024
 AAN4828	 AAN5028	 AAN5428†	 AAN5828†	 AAN6028†
 AAN4830**	 AAN5030**	 AAN5430**	 AAN5830**	 AAN6030**
 AAN4834**	 AAN5034**	 AAN5434**	 AAN5834**	 AAN6034**
 AAN4838**	 AAN5038**	 AAN5438**	 AAN5838**	 AAN6038**
 AAN4840**	 AAN5040**	 AAN5440**	 AAN5840**	 AAN6040**



Custom-size windows are available in 1/8" (3) increments.  
See page 60 for custom sizes and specifications.

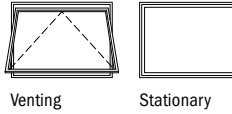

Choose venting or stationary.

**Awning window must be installed to vent as shown and should not be rotated and used as a hopper.**

Details and grille patterns shown on page 35.

• "Window Dimension" always refers to outside frame to frame dimension.  
 • **"Minimum Rough Opening" dimensions may need to be increased to allow for use of building wraps, flashing, sill panning, brackets, fasteners or other items. See installation information on page 170.**  
 \* Dimensions in parentheses are in millimeters.  
 \* Multi-point locks are standard.  
 † Factory-applied operator slide shoe bracket.

## Awning Window Opening and Area Specifications

Window Number	Clear Opening in Full Open Position		Glass Area Sq. Ft./ (m <sup>2</sup> )	Vent Sq. Ft./ (m <sup>2</sup> )	Top of Subfloor to Top of Inside Sill Stop Inches/ (mm)	Overall Window Area Sq. Ft./ (m <sup>2</sup> )	
	Clear Opening Sq. Ft./ (m <sup>2</sup> )	Width Inches/ (mm)					Depth Inches/ (mm)
AAN1814	0.59 (0.05)	14 5/16" (364)	5 7/8" (150)	0.68 (0.06)	0.59 (0.05)	70 1/16" (1779)	2.04 (0.19)
AAN1818	0.59 (0.05)	14 5/16" (364)	5 7/8" (150)	1.03 (0.10)	0.59 (0.05)	66 1/16" (1678)	2.57 (0.24)
AAN18110	0.59 (0.05)	14 5/16" (364)	5 7/8" (150)	1.21 (0.11)	0.59 (0.05)	64 1/16" (1627)	2.84 (0.26)
AAN1820	0.59 (0.05)	14 5/16" (364)	5 7/8" (150)	1.38 (0.13)	0.59 (0.05)	62 1/16" (1576)	3.11 (0.29)
AAN1824	0.59 (0.05)	14 5/16" (364)	5 7/8" (150)	1.73 (0.16)	0.59 (0.05)	58 1/16" (1475)	3.64 (0.34)
AAN1828	0.59 (0.05)	14 5/16" (364)	5 7/8" (150)	2.08 (0.19)	0.59 (0.05)	54 1/16" (1373)	4.18 (0.39)
AAN1830	0.59 (0.05)	14 5/16" (364)	5 7/8" (150)	2.43 (0.23)	0.59 (0.05)	50 1/16" (1271)	4.71 (0.44)
AAN1834	0.59 (0.05)	14 5/16" (364)	5 7/8" (150)	2.78 (0.26)	0.59 (0.05)	46 1/16" (1170)	5.25 (0.49)
AAN1838	0.59 (0.05)	14 5/16" (364)	5 7/8" (150)	3.13 (0.29)	0.59 (0.05)	42 1/16" (1068)	5.78 (0.54)
AAN1840	0.59 (0.05)	14 5/16" (364)	5 7/8" (150)	3.48 (0.32)	0.59 (0.05)	38 1/16" (967)	6.32 (0.59)
AAN2014	0.75 (0.07)	18 5/16" (465)	5 7/8" (150)	0.90 (0.08)	0.75 (0.07)	70 1/16" (1779)	2.46 (0.23)
AAN2018	0.75 (0.07)	18 5/16" (465)	5 7/8" (150)	1.36 (0.13)	0.75 (0.07)	66 1/16" (1678)	3.11 (0.29)
AAN20110	0.75 (0.07)	18 5/16" (465)	5 7/8" (150)	1.59 (0.15)	0.75 (0.07)	64 1/16" (1627)	3.43 (0.32)
AAN2020	0.75 (0.07)	18 5/16" (465)	5 7/8" (150)	1.82 (0.17)	0.75 (0.07)	62 1/16" (1576)	3.75 (0.35)
AAN2024	0.75 (0.07)	18 5/16" (465)	5 7/8" (150)	2.28 (0.21)	0.75 (0.07)	58 1/16" (1475)	4.40 (0.41)
AAN2028	0.75 (0.07)	18 5/16" (465)	5 7/8" (150)	2.74 (0.25)	0.75 (0.07)	54 1/16" (1373)	5.05 (0.47)
AAN2030	0.75 (0.07)	18 5/16" (465)	5 7/8" (150)	3.21 (0.30)	0.75 (0.07)	50 1/16" (1271)	5.69 (0.53)
AAN2034	0.75 (0.07)	18 5/16" (465)	5 7/8" (150)	3.67 (0.34)	0.75 (0.07)	46 1/16" (1170)	6.34 (0.59)
AAN2038	0.75 (0.07)	18 5/16" (465)	5 7/8" (150)	4.13 (0.38)	0.75 (0.07)	42 1/16" (1068)	6.98 (0.65)
AAN2040	0.75 (0.07)	18 5/16" (465)	5 7/8" (150)	4.59 (0.43)	0.75 (0.07)	38 1/16" (967)	7.63 (0.71)
AAN2414	0.91 (0.08)	22 5/16" (567)	5 7/8" (150)	1.12 (0.10)	0.91 (0.08)	70 1/16" (1779)	2.89 (0.27)
AAN2418	0.91 (0.08)	22 5/16" (567)	5 7/8" (150)	1.69 (0.16)	0.91 (0.08)	66 1/16" (1678)	3.64 (0.34)
AAN24110	0.91 (0.08)	22 5/16" (567)	5 7/8" (150)	1.97 (0.18)	0.91 (0.08)	64 1/16" (1627)	4.02 (0.37)
AAN2420	0.91 (0.08)	22 5/16" (567)	5 7/8" (150)	2.26 (0.21)	0.91 (0.08)	62 1/16" (1576)	4.40 (0.41)
AAN2424	0.91 (0.08)	22 5/16" (567)	5 7/8" (150)	2.83 (0.26)	0.91 (0.08)	58 1/16" (1475)	5.16 (0.48)
AAN2428	0.91 (0.08)	22 5/16" (567)	5 7/8" (150)	3.41 (0.32)	0.91 (0.08)	54 1/16" (1373)	5.91 (0.55)
AAN2430	0.91 (0.08)	22 5/16" (567)	5 7/8" (150)	3.98 (0.37)	0.91 (0.08)	50 1/16" (1271)	6.67 (0.62)
AAN2434	0.91 (0.08)	22 5/16" (567)	5 7/8" (150)	4.55 (0.42)	0.91 (0.08)	46 1/16" (1170)	7.43 (0.69)
AAN2438	0.91 (0.08)	22 5/16" (567)	5 7/8" (150)	5.12 (0.48)	0.91 (0.08)	42 1/16" (1068)	8.18 (0.76)
AAN2440	0.91 (0.08)	22 5/16" (567)	5 7/8" (150)	5.69 (0.53)	0.91 (0.08)	38 1/16" (967)	8.94 (0.83)
AAN2614	0.99 (0.09)	24 5/16" (618)	5 7/8" (150)	1.22 (0.11)	0.99 (0.09)	70 1/16" (1779)	3.10 (0.29)
AAN2618	0.99 (0.09)	24 5/16" (618)	5 7/8" (150)	1.85 (0.17)	0.99 (0.09)	66 1/16" (1678)	3.91 (0.36)
AAN26110	0.99 (0.09)	24 5/16" (618)	5 7/8" (150)	2.17 (0.20)	0.99 (0.09)	64 1/16" (1627)	4.32 (0.40)
AAN2620	0.99 (0.09)	24 5/16" (618)	5 7/8" (150)	2.48 (0.23)	0.99 (0.09)	62 1/16" (1576)	4.72 (0.44)
AAN2624	0.99 (0.09)	24 5/16" (618)	5 7/8" (150)	3.11 (0.29)	0.99 (0.09)	58 1/16" (1475)	5.54 (0.51)
AAN2628	0.99 (0.09)	24 5/16" (618)	5 7/8" (150)	3.75 (0.35)	0.99 (0.09)	54 1/16" (1373)	6.35 (0.59)
AAN2630	0.99 (0.09)	24 5/16" (618)	5 7/8" (150)	4.36 (0.41)	0.99 (0.09)	50 1/16" (1271)	7.16 (0.67)
AAN2634	0.99 (0.09)	24 5/16" (618)	5 7/8" (150)	4.99 (0.46)	0.99 (0.09)	46 1/16" (1170)	7.97 (0.74)
AAN2638	0.99 (0.09)	24 5/16" (618)	5 7/8" (150)	5.62 (0.52)	0.99 (0.09)	42 1/16" (1068)	8.79 (0.82)
AAN2640	0.99 (0.09)	24 5/16" (618)	5 7/8" (150)	6.25 (0.58)	0.99 (0.09)	38 1/16" (967)	9.60 (0.89)
AAN2814	1.08 (0.10)	26 5/16" (668)	5 7/8" (150)	1.33 (0.12)	1.08 (0.10)	70 1/16" (1779)	3.31 (0.31)
AAN2818	1.08 (0.10)	26 5/16" (668)	5 7/8" (150)	2.02 (0.19)	1.08 (0.10)	66 1/16" (1678)	4.18 (0.39)
AAN28110	1.08 (0.10)	26 5/16" (668)	5 7/8" (150)	2.36 (0.22)	1.08 (0.10)	64 1/16" (1627)	4.61 (0.43)
AAN2820	1.08 (0.10)	26 5/16" (668)	5 7/8" (150)	2.70 (0.25)	1.08 (0.10)	62 1/16" (1576)	5.05 (0.47)
AAN2824	1.08 (0.10)	26 5/16" (668)	5 7/8" (150)	3.38 (0.31)	1.08 (0.10)	58 1/16" (1475)	5.91 (0.55)
AAN2828	1.08 (0.10)	26 5/16" (668)	5 7/8" (150)	4.07 (0.38)	1.08 (0.10)	54 1/16" (1373)	6.78 (0.63)
AAN2830	1.08 (0.10)	26 5/16" (668)	5 7/8" (150)	4.75 (0.44)	1.08 (0.10)	50 1/16" (1271)	7.65 (0.71)
AAN2834	1.08 (0.10)	26 5/16" (668)	5 7/8" (150)	5.43 (0.50)	1.08 (0.10)	46 1/16" (1170)	8.52 (0.79)
AAN2838	1.08 (0.10)	26 5/16" (668)	5 7/8" (150)	6.11 (0.57)	1.08 (0.10)	42 1/16" (1068)	9.39 (0.87)
AAN2840	1.08 (0.10)	26 5/16" (668)	5 7/8" (150)	6.80 (0.63)	1.08 (0.10)	38 1/16" (967)	10.25 (0.95)
AAN21014	1.16 (0.11)	28 5/16" (719)	5 7/8" (150)	1.44 (0.13)	1.16 (0.11)	70 1/16" (1779)	3.52 (0.33)
AAN21018	1.16 (0.11)	28 5/16" (719)	5 7/8" (150)	2.18 (0.20)	1.16 (0.11)	66 1/16" (1678)	4.45 (0.41)
AAN210110	1.16 (0.11)	28 5/16" (719)	5 7/8" (150)	2.55 (0.24)	1.16 (0.11)	64 1/16" (1627)	4.91 (0.46)
AAN21020	1.16 (0.11)	28 5/16" (719)	5 7/8" (150)	2.92 (0.27)	1.16 (0.11)	62 1/16" (1576)	5.37 (0.50)
AAN21024	1.16 (0.11)	28 5/16" (719)	5 7/8" (150)	3.66 (0.34)	1.16 (0.11)	58 1/16" (1475)	6.29 (0.58)
AAN21028	1.16 (0.11)	28 5/16" (719)	5 7/8" (150)	4.40 (0.41)	1.16 (0.11)	54 1/16" (1373)	7.22 (0.67)
AAN21030	1.16 (0.11)	28 5/16" (719)	5 7/8" (150)	5.14 (0.48)	1.16 (0.11)	50 1/16" (1271)	8.14 (0.76)
AAN21034	1.16 (0.11)	28 5/16" (719)	5 7/8" (150)	5.87 (0.55)	1.16 (0.11)	46 1/16" (1170)	9.06 (0.84)
AAN21038	1.16 (0.11)	28 5/16" (719)	5 7/8" (150)	6.61 (0.61)	1.16 (0.11)	42 1/16" (1068)	9.99 (0.93)

\*Top of Subfloor to Top of Inside Sill Stop" is calculated based upon a structural header height of 6'-10 1/2" (2096).  
 \*Dimensions in parentheses are in millimeters or square meters.

continued on next page

**Awning Window Opening and Area Specifications** *(continued)*

Window Number	Clear Opening Sq. Ft./ (m <sup>2</sup> )	Clear Opening in Full Open Position		Glass Area Sq. Ft./ (m <sup>2</sup> )	Vent Sq. Ft./ (m <sup>2</sup> )	Top of Subfloor to Top of Inside Sill Stop Inches/ (mm)	Overall Window Area Sq. Ft./ (m <sup>2</sup> )
		Width Inches/ (mm)	Depth Inches/ (mm)				
AAN21040	1.16 (0.11)	28 5/16" (719)	5 7/8" (150)	7.35 (0.68)	1.16 (0.11)	38 1/16" (967)	10.91 (1.01)
AAN3014	1.24 (0.12)	30 5/16" (770)	5 7/8" (150)	1.55 (0.14)	1.24 (0.12)	70 1/16" (1779)	3.73 (0.35)
AAN3018	1.24 (0.12)	30 5/16" (770)	5 7/8" (150)	2.34 (0.22)	1.24 (0.12)	66 1/16" (1678)	4.71 (0.44)
AAN30110	1.24 (0.12)	30 5/16" (770)	5 7/8" (150)	2.74 (0.25)	1.24 (0.12)	64 1/16" (1627)	5.20 (0.48)
AAN3020	1.24 (0.12)	30 5/16" (770)	5 7/8" (150)	3.14 (0.29)	1.24 (0.12)	62 1/16" (1576)	5.69 (0.53)
AAN3024	1.24 (0.12)	30 5/16" (770)	5 7/8" (150)	3.93 (0.37)	1.24 (0.12)	58 1/16" (1475)	6.67 (0.62)
AAN3028	1.24 (0.12)	30 5/16" (770)	5 7/8" (150)	4.73 (0.44)	1.24 (0.12)	54 1/16" (1373)	7.56 (0.70)
AAN3030	1.24 (0.12)	30 5/16" (770)	5 7/8" (150)	5.52 (0.51)	1.24 (0.12)	50 1/16" (1271)	8.63 (0.80)
AAN3034	1.24 (0.12)	30 5/16" (770)	5 7/8" (150)	6.32 (0.59)	1.24 (0.12)	46 1/16" (1170)	9.61 (0.89)
AAN3038	1.24 (0.12)	30 5/16" (770)	5 7/8" (150)	7.11 (0.66)	1.24 (0.12)	42 1/16" (1068)	10.59 (0.98)
AAN3040	1.24 (0.12)	30 5/16" (770)	5 7/8" (150)	7.90 (0.73)	1.24 (0.12)	38 1/16" (967)	11.57 (1.07)
AAN3214	1.32 (0.12)	32 5/16" (821)	5 7/8" (150)	1.66 (0.15)	1.32 (0.12)	70 1/16" (1779)	3.95 (0.37)
AAN3218	1.32 (0.12)	32 5/16" (821)	5 7/8" (150)	2.51 (0.23)	1.32 (0.12)	66 1/16" (1678)	4.98 (0.46)
AAN32110	1.32 (0.12)	32 5/16" (821)	5 7/8" (150)	2.93 (0.27)	1.32 (0.12)	64 1/16" (1627)	5.50 (0.51)
AAN3220	1.32 (0.12)	32 5/16" (821)	5 7/8" (150)	3.36 (0.31)	1.32 (0.12)	62 1/16" (1576)	6.01 (0.56)
AAN3224	1.32 (0.12)	32 5/16" (821)	5 7/8" (150)	4.21 (0.39)	1.32 (0.12)	58 1/16" (1475)	7.05 (0.65)
AAN3228	1.32 (0.12)	32 5/16" (821)	5 7/8" (150)	5.06 (0.47)	1.32 (0.12)	54 1/16" (1373)	8.08 (0.75)
AAN3230	1.32 (0.12)	32 5/16" (821)	5 7/8" (150)	5.91 (0.55)	1.32 (0.12)	50 1/16" (1271)	9.12 (0.85)
AAN3234	1.32 (0.12)	32 5/16" (821)	5 7/8" (150)	6.76 (0.63)	1.32 (0.12)	46 1/16" (1170)	10.15 (0.94)
AAN3238	1.32 (0.12)	32 5/16" (821)	5 7/8" (150)	7.61 (0.71)	1.32 (0.12)	42 1/16" (1068)	11.19 (1.04)
AAN3240	1.32 (0.12)	32 5/16" (821)	5 7/8" (150)	8.46 (0.79)	1.32 (0.12)	38 1/16" (967)	12.22 (1.14)
AAN3414	1.40 (0.13)	34 5/16" (872)	5 7/8" (150)	1.77 (0.16)	1.40 (0.13)	70 1/16" (1779)	4.16 (0.39)
AAN3418	1.40 (0.13)	34 5/16" (872)	5 7/8" (150)	2.67 (0.25)	1.40 (0.13)	66 1/16" (1678)	5.25 (0.49)
AAN34110	1.40 (0.13)	34 5/16" (872)	5 7/8" (150)	3.12 (0.29)	1.40 (0.13)	64 1/16" (1627)	5.79 (0.54)
AAN3420	1.40 (0.13)	34 5/16" (872)	5 7/8" (150)	3.58 (0.33)	1.40 (0.13)	62 1/16" (1576)	6.34 (0.59)
AAN3424	1.40 (0.13)	34 5/16" (872)	5 7/8" (150)	4.48 (0.42)	1.40 (0.13)	58 1/16" (1475)	7.43 (0.69)
AAN3428	1.40 (0.13)	34 5/16" (872)	5 7/8" (150)	5.39 (0.50)	1.40 (0.13)	54 1/16" (1373)	8.52 (0.79)
AAN3430	1.40 (0.13)	34 5/16" (872)	5 7/8" (150)	6.29 (0.58)	1.40 (0.13)	50 1/16" (1271)	9.61 (0.89)
AAN3434	1.40 (0.13)	34 5/16" (872)	5 7/8" (150)	7.20 (0.67)	1.40 (0.13)	46 1/16" (1170)	10.70 (0.99)
AAN3438	1.40 (0.13)	34 5/16" (872)	5 7/8" (150)	8.10 (0.75)	1.40 (0.13)	42 1/16" (1068)	11.79 (1.10)
AAN3440	1.40 (0.13)	34 5/16" (872)	5 7/8" (150)	9.01 (0.84)	1.40 (0.13)	38 1/16" (967)	12.88 (1.20)
AAN3814	1.57 (0.15)	38 5/16" (973)	5 7/8" (150)	1.98 (0.18)	1.57 (0.15)	70 1/16" (1779)	4.58 (0.43)
AAN3818	1.57 (0.15)	38 5/16" (973)	5 7/8" (150)	3.00 (0.28)	1.57 (0.15)	66 1/16" (1678)	5.78 (0.54)
AAN38110	1.57 (0.15)	38 5/16" (973)	5 7/8" (150)	3.51 (0.33)	1.57 (0.15)	64 1/16" (1627)	6.38 (0.59)
AAN3820	1.57 (0.15)	38 5/16" (973)	5 7/8" (150)	4.02 (0.37)	1.57 (0.15)	62 1/16" (1576)	6.98 (0.65)
AAN3824	1.57 (0.15)	38 5/16" (973)	5 7/8" (150)	5.03 (0.47)	1.57 (0.15)	58 1/16" (1475)	8.18 (0.76)
AAN3828	1.57 (0.15)	38 5/16" (973)	5 7/8" (150)	6.05 (0.56)	1.57 (0.15)	54 1/16" (1373)	9.39 (0.87)
AAN3830	1.57 (0.15)	38 5/16" (973)	5 7/8" (150)	7.07 (0.66)	1.57 (0.15)	50 1/16" (1271)	10.59 (0.98)
AAN3834	1.57 (0.15)	38 5/16" (973)	5 7/8" (150)	8.08 (0.75)	1.57 (0.15)	46 1/16" (1170)	11.79 (1.10)
AAN3838	1.57 (0.15)	38 5/16" (973)	5 7/8" (150)	9.10 (0.85)	1.57 (0.15)	42 1/16" (1068)	12.99 (1.21)
AAN3840	1.57 (0.15)	38 5/16" (973)	5 7/8" (150)	10.12 (0.94)	1.57 (0.15)	38 1/16" (967)	14.19 (1.32)
AAN4014	1.73 (0.16)	42 5/16" (1075)	5 7/8" (150)	2.20 (0.20)	1.73 (0.16)	70 1/16" (1779)	5.00 (0.46)
AAN4018	1.73 (0.16)	42 5/16" (1075)	5 7/8" (150)	3.33 (0.31)	1.73 (0.16)	66 1/16" (1678)	6.32 (0.59)
AAN40110	1.73 (0.16)	42 5/16" (1075)	5 7/8" (150)	3.89 (0.36)	1.73 (0.16)	64 1/16" (1627)	6.97 (0.65)
AAN4020	1.73 (0.16)	42 5/16" (1075)	5 7/8" (150)	4.46 (0.41)	1.73 (0.16)	62 1/16" (1576)	7.63 (0.71)
AAN4024	1.73 (0.16)	42 5/16" (1075)	5 7/8" (150)	5.58 (0.52)	1.73 (0.16)	58 1/16" (1475)	8.94 (0.83)
AAN4028	1.73 (0.16)	42 5/16" (1075)	5 7/8" (150)	6.71 (0.62)	1.73 (0.16)	54 1/16" (1373)	10.25 (0.95)
AAN4030	1.73 (0.16)	42 5/16" (1075)	5 7/8" (150)	7.84 (0.73)	1.73 (0.16)	50 1/16" (1271)	11.57 (1.07)
AAN4034	1.73 (0.16)	42 5/16" (1075)	5 7/8" (150)	8.97 (0.83)	1.73 (0.16)	46 1/16" (1170)	12.88 (1.20)
AAN4038	1.73 (0.16)	42 5/16" (1075)	5 7/8" (150)	10.09 (0.94)	1.73 (0.16)	42 1/16" (1068)	14.19 (1.32)
AAN4040	1.73 (0.16)	42 5/16" (1075)	5 7/8" (150)	11.22 (1.04)	1.73 (0.16)	38 1/16" (967)	15.50 (1.44)
AAN4414	1.90 (0.18)	46 5/16" (1176)	5 7/8" (150)	2.42 (0.22)	1.90 (0.18)	70 1/16" (1779)	5.43 (0.50)
AAN4418	1.90 (0.18)	46 5/16" (1176)	5 7/8" (150)	3.66 (0.34)	1.90 (0.18)	66 1/16" (1678)	6.85 (0.64)
AAN44110	1.90 (0.18)	46 5/16" (1176)	5 7/8" (150)	4.27 (0.40)	1.90 (0.18)	64 1/16" (1627)	7.56 (0.70)
AAN4420	1.90 (0.18)	46 5/16" (1176)	5 7/8" (150)	4.89 (0.45)	1.90 (0.18)	62 1/16" (1576)	8.28 (0.77)
AAN4424	1.90 (0.18)	46 5/16" (1176)	5 7/8" (150)	6.13 (0.57)	1.90 (0.18)	58 1/16" (1475)	9.70 (0.90)
AAN4428	1.90 (0.18)	46 5/16" (1176)	5 7/8" (150)	7.37 (0.68)	1.90 (0.18)	54 1/16" (1373)	11.12 (1.03)
AAN4430	1.90 (0.18)	46 5/16" (1176)	5 7/8" (150)	8.61 (0.80)	1.90 (0.18)	50 1/16" (1271)	12.55 (1.17)
AAN4434	1.90 (0.18)	46 5/16" (1176)	5 7/8" (150)	9.85 (0.92)	1.90 (0.18)	46 1/16" (1170)	13.97 (1.30)

\*Top of Subfloor to Top of Inside Sill Stop" is calculated based upon a structural header height of 6'-10 1/2" (2096).  
 •Dimensions in parentheses are in millimeters or square meters.

*continued on next page*

A-Series Casement & Awning Windows

## Awning Window Opening and Area Specifications (continued)

Window Number	Clear Opening in Full Open Position		Glass Area Sq. Ft./ (m <sup>2</sup> )	Vent Sq. Ft./ (m <sup>2</sup> )	Top of Subfloor to Top of Inside Sill Stop Inches/ (mm)	Overall Window Area Sq. Ft./ (m <sup>2</sup> )
	Clear Opening Sq. Ft./ (m <sup>2</sup> )	Width Inches/ (mm)				
AAN4438	1.90 (0.18)	46 5/16" (1176)	5 7/8" (150)	11.09 (1.03)	1.90 (0.18)	42 1/16" (1068) 15.39 (1.43)
AAN4440	1.90 (0.18)	46 5/16" (1176)	5 7/8" (150)	12.33 (1.15)	1.90 (0.18)	38 1/16" (967) 16.82 (1.56)
AAN4814	2.06 (0.19)	50 5/16" (1278)	5 7/8" (150)	2.63 (0.24)	2.06 (0.19)	70 1/16" (1779) 5.85 (0.54)
AAN4818	2.06 (0.19)	50 5/16" (1278)	5 7/8" (150)	3.98 (0.37)	2.06 (0.19)	66 1/16" (1678) 7.39 (0.69)
AAN48110	2.06 (0.19)	50 5/16" (1278)	5 7/8" (150)	4.66 (0.43)	2.06 (0.19)	64 1/16" (1627) 8.15 (0.76)
AAN4820	2.06 (0.19)	50 5/16" (1278)	5 7/8" (150)	5.33 (0.50)	2.06 (0.19)	62 1/16" (1576) 8.92 (0.83)
AAN4824	2.06 (0.19)	50 5/16" (1278)	5 7/8" (150)	6.68 (0.62)	2.06 (0.19)	58 1/16" (1475) 10.46 (0.97)
AAN4828	2.06 (0.19)	50 5/16" (1278)	5 7/8" (150)	8.03 (0.75)	2.06 (0.19)	54 1/16" (1373) 11.99 (1.11)
AAN4830	2.06 (0.19)	50 5/16" (1278)	5 7/8" (150)	9.38 (0.87)	2.06 (0.19)	50 1/16" (1271) 13.53 (1.26)
AAN4834	2.06 (0.19)	50 5/16" (1278)	5 7/8" (150)	10.73 (1.00)	2.06 (0.19)	46 1/16" (1170) 15.06 (1.40)
AAN4838	2.06 (0.19)	50 5/16" (1278)	5 7/8" (150)	12.08 (1.12)	2.06 (0.19)	42 1/16" (1068) 16.59 (1.54)
AAN4840	2.06 (0.19)	50 5/16" (1278)	5 7/8" (150)	13.43 (1.25)	2.06 (0.19)	38 1/16" (967) 18.13 (1.68)
AAN5014	2.22 (0.21)	54 5/16" (1380)	5 7/8" (150)	2.85 (0.26)	2.22 (0.21)	70 1/16" (1779) 6.28 (0.58)
AAN5018	2.22 (0.21)	54 5/16" (1380)	5 7/8" (150)	4.31 (0.40)	2.22 (0.21)	66 1/16" (1678) 7.92 (0.74)
AAN50110	2.22 (0.21)	54 5/16" (1380)	5 7/8" (150)	5.04 (0.47)	2.22 (0.21)	64 1/16" (1627) 8.74 (0.81)
AAN5020	2.22 (0.21)	54 5/16" (1380)	5 7/8" (150)	5.77 (0.54)	2.22 (0.21)	62 1/16" (1576) 9.57 (0.89)
AAN5024	2.22 (0.21)	54 5/16" (1380)	5 7/8" (150)	7.23 (0.67)	2.22 (0.21)	58 1/16" (1475) 11.21 (1.04)
AAN5028	2.39 (0.22)	54 5/16" (1380)	5 7/8" (150)	9.36 (0.87)	2.39 (0.22)	54 1/16" (1373) 13.73 (1.28)
AAN5030	2.22 (0.21)	54 5/16" (1380)	5 7/8" (150)	10.16 (0.94)	2.22 (0.21)	50 1/16" (1271) 14.50 (1.35)
AAN5034	2.05 (0.19)	54 5/16" (1380)	5 7/8" (150)	11.62 (1.08)	2.05 (0.19)	46 1/16" (1170) 16.15 (1.50)
AAN5038	1.88 (0.17)	54 5/16" (1380)	5 7/8" (150)	13.08 (1.22)	1.88 (0.17)	42 1/16" (1068) 17.80 (1.65)
AAN5040	1.71 (0.16)	54 5/16" (1380)	5 7/8" (150)	14.54 (1.35)	1.71 (0.16)	38 1/16" (967) 19.44 (1.81)
AAN5414	2.39 (0.22)	58 5/16" (1481)	5 7/8" (150)	3.07 (0.29)	2.39 (0.22)	70 1/16" (1779) 6.70 (0.62)
AAN5418	2.39 (0.22)	58 5/16" (1481)	5 7/8" (150)	4.64 (0.43)	2.39 (0.22)	66 1/16" (1678) 8.46 (0.79)
AAN54110	2.39 (0.22)	58 5/16" (1481)	5 7/8" (150)	5.42 (0.50)	2.39 (0.22)	64 1/16" (1627) 9.33 (0.87)
AAN5420	2.39 (0.22)	58 5/16" (1481)	5 7/8" (150)	6.21 (0.58)	2.39 (0.22)	62 1/16" (1576) 10.21 (0.95)
AAN5424	2.39 (0.22)	58 5/16" (1481)	5 7/8" (150)	7.78 (0.72)	2.39 (0.22)	58 1/16" (1475) 11.97 (1.11)
AAN5028	2.22 (0.21)	58 5/16" (1481)	5 7/8" (150)	8.69 (0.81)	2.22 (0.21)	54 1/16" (1373) 12.86 (1.19)
AAN5430	2.39 (0.22)	58 5/16" (1481)	5 7/8" (150)	10.93 (1.02)	2.39 (0.22)	50 1/16" (1271) 15.48 (1.44)
AAN5434	2.56 (0.24)	58 5/16" (1481)	5 7/8" (150)	12.50 (1.16)	2.56 (0.24)	46 1/16" (1170) 17.24 (1.60)
AAN5438	2.73 (0.25)	58 5/16" (1481)	5 7/8" (150)	14.07 (1.31)	2.73 (0.25)	42 1/16" (1068) 19.00 (1.77)
AAN5440	2.90 (0.27)	58 5/16" (1481)	5 7/8" (150)	15.64 (1.45)	2.90 (0.27)	38 1/16" (967) 20.75 (1.93)
AAN5814	2.55 (0.24)	62 5/16" (1583)	5 7/8" (150)	3.28 (0.30)	2.55 (0.24)	70 1/16" (1779) 7.12 (0.66)
AAN5818	2.55 (0.24)	62 5/16" (1583)	5 7/8" (150)	4.97 (0.46)	2.55 (0.24)	66 1/16" (1678) 8.99 (0.84)
AAN58110	2.55 (0.24)	62 5/16" (1583)	5 7/8" (150)	5.81 (0.54)	2.55 (0.24)	64 1/16" (1627) 9.92 (0.92)
AAN5820	2.55 (0.24)	62 5/16" (1583)	5 7/8" (150)	6.65 (0.62)	2.55 (0.24)	62 1/16" (1576) 10.86 (1.01)
AAN5824	2.55 (0.24)	62 5/16" (1583)	5 7/8" (150)	8.33 (0.77)	2.55 (0.24)	58 1/16" (1475) 12.73 (1.18)
AAN5828	2.55 (0.24)	62 5/16" (1583)	5 7/8" (150)	10.02 (0.93)	2.55 (0.24)	54 1/16" (1373) 14.59 (1.36)
AAN5830	2.55 (0.24)	62 5/16" (1583)	5 7/8" (150)	11.70 (1.09)	2.55 (0.24)	50 1/16" (1271) 16.46 (1.53)
AAN5834	2.55 (0.24)	62 5/16" (1583)	5 7/8" (150)	13.38 (1.24)	2.55 (0.24)	46 1/16" (1170) 18.33 (1.70)
AAN5838	2.55 (0.24)	62 5/16" (1583)	5 7/8" (150)	15.07 (1.40)	2.55 (0.24)	42 1/16" (1068) 20.20 (1.88)
AAN5840	2.55 (0.24)	62 5/16" (1583)	5 7/8" (150)	16.75 (1.56)	2.55 (0.24)	38 1/16" (967) 22.07 (2.05)
AAN6014	2.71 (0.25)	66 5/16" (1684)	5 7/8" (150)	3.50 (0.33)	2.71 (0.25)	70 1/16" (1779) 7.55 (0.70)
AAN6018	2.71 (0.25)	66 5/16" (1684)	5 7/8" (150)	5.29 (0.49)	2.71 (0.25)	66 1/16" (1678) 9.53 (0.89)
AAN60110	2.71 (0.25)	66 5/16" (1684)	5 7/8" (150)	6.19 (0.58)	2.71 (0.25)	64 1/16" (1627) 10.51 (0.98)
AAN6020	2.71 (0.25)	66 5/16" (1684)	5 7/8" (150)	7.09 (0.66)	2.71 (0.25)	62 1/16" (1576) 11.50 (1.07)
AAN6024	2.71 (0.25)	66 5/16" (1684)	5 7/8" (150)	8.88 (0.82)	2.71 (0.25)	58 1/16" (1475) 13.48 (1.25)
AAN6028	2.71 (0.25)	66 5/16" (1684)	5 7/8" (150)	10.68 (0.99)	2.71 (0.25)	54 1/16" (1373) 15.46 (1.44)
AAN6030	2.71 (0.25)	66 5/16" (1684)	5 7/8" (150)	12.47 (1.16)	2.71 (0.25)	50 1/16" (1271) 17.44 (1.62)
AAN6034	2.71 (0.25)	66 5/16" (1684)	5 7/8" (150)	14.27 (1.33)	2.71 (0.25)	46 1/16" (1170) 19.42 (1.80)
AAN6038	2.71 (0.25)	66 5/16" (1684)	5 7/8" (150)	16.06 (1.49)	2.71 (0.25)	42 1/16" (1068) 21.40 (1.99)
AAN6040	2.71 (0.25)	66 5/16" (1684)	5 7/8" (150)	17.85 (1.66)	2.71 (0.25)	38 1/16" (967) 23.38 (2.17)

\* "Top of Subfloor to Top of Inside Sill Stop" is calculated based upon a structural header height of 6'-10 1/2" (2096).  
 \* Dimensions in parentheses are in millimeters or square meters.

**Grille Patterns**

	Queen Anne	Diamond	Prairie A	Specified Equal Light with Simulated Meeting Rail	Colonial	Modified Colonial	Modified Colonial with Simulated Meeting Rail	Tall Fractional	Tall Fractional with Simulated Meeting Rail	Short Fractional	Short Fractional with Simulated Meeting Rail
<b>Casement</b>											
<b>Awning</b>											

• Andersen® Finelight™ grilles available in 3/4" (19) profile only.

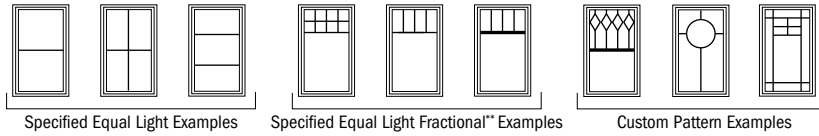

\*\*Daylight opening dimensions are available at 8" (203), 10" (254), 12" (305), center and custom dimensions.

**Number of lights and overall pattern varies with window size.**

**Patterns shown may not be available for all sizes.** Specified equal light and custom patterns are also available. For more information on divided light, see page 15 or visit [andersenwindows.com/grilles](http://andersenwindows.com/grilles).

A-Series Casement & Awning Windows

**Awning Window Details**

Scale 1 1/2" (38) = 1'-0" (305) – 1:8

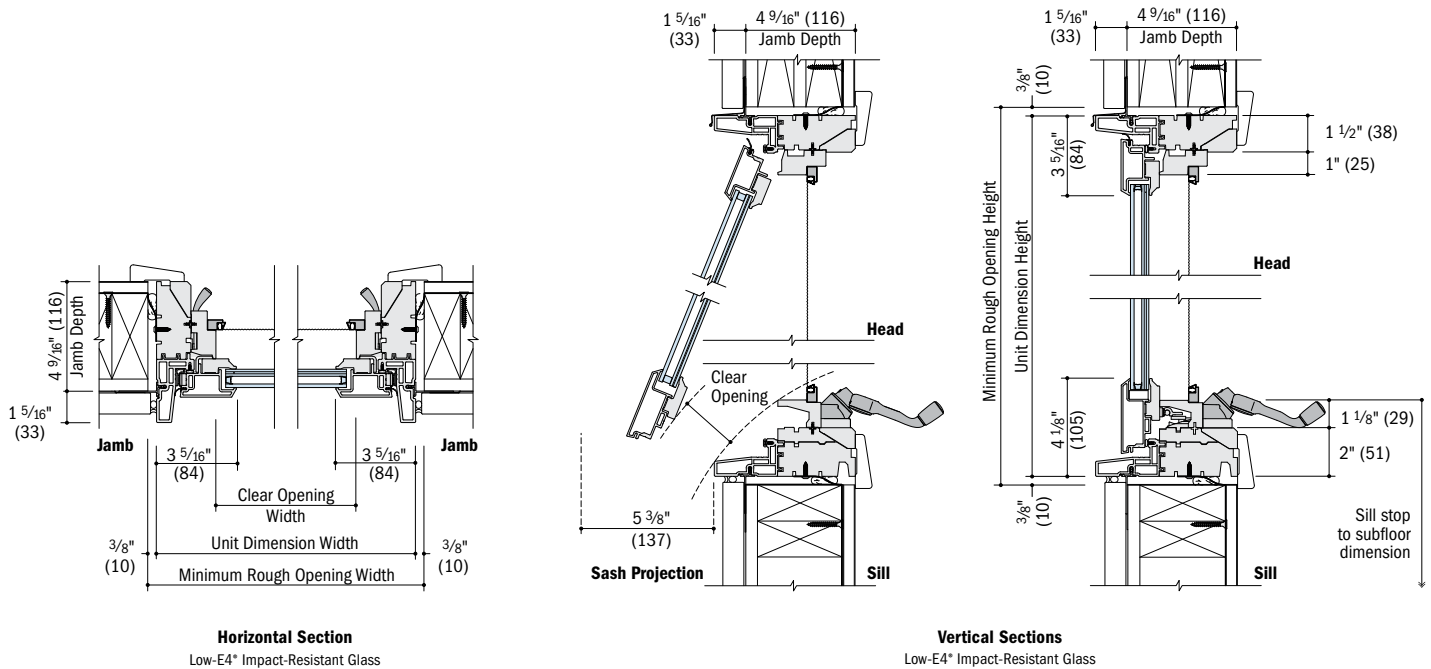

See pages 57-59 for horizontal and vertical joining details.

- 4 9/16" (116) jamb depth measurement is from back side of installation flange.
- Light-colored areas are parts included with window. Dark-colored areas are additional Andersen® parts required to complete window assembly as shown.
- Dimensions in parentheses are in millimeters.
- **Minimum rough opening dimensions may need to be increased to allow for use of building wraps, flashing, sill panning, brackets, fasteners or other items. See installation information on page 170.**
- Details are for illustration only and are not intended to represent product installation methods or materials. Refer to product installation guides at [andersenwindows.com](http://andersenwindows.com).

## Table of Double-Hung Window Sizes

Scale 1/8" (3) = 1'-0" (305) – 1:96

Notes on the next page also apply to this page.

Unit Dimension	1'-7 1/4"	1'-11 1/4"	2'-3 1/4"	2'-5 1/4"	2'-7 1/4"	2'-9 1/4"	2'-11 1/4"	3'-1 1/4"	3'-3 1/4"	3'-7 1/4"	3'-11 1/4"
	(489)	(591)	(692)	(743)	(794)	(845)	(895)	(946)	(997)	(1099)	(1200)
<b>Minimum Rough Opening</b>	1'-8"	2'-0"	2'-4"	2'-6"	2'-8"	2'-10"	3'-0"	3'-2"	3'-4"	3'-8"	4'-0"
	(508)	(610)	(711)	(762)	(813)	(864)	(914)	(965)	(1016)	(1118)	(1219)
Unobstructed Glass (lower sash only)	12 5/8"	16 5/8"	20 5/8"	22 5/8"	24 5/8"	26 5/8"	28 5/8"	30 5/8"	32 5/8"	36 5/8"	40 5/8"
	(321)	(422)	(524)	(575)	(625)	(676)	(727)	(778)	(829)	(930)	(1032)

2:3 cottage or 3:2 reverse cottage sash ratio available for all standard widths and heights up to 6'-7 1/4" (2013). Custom sizes available. See page 61.

CUSTOM SIZES AVAILABLE												
2'-11 1/4" (895)												<p>Cottage Reverse Cottage</p>
3'-3 1/4" (997)	ADH1830	ADH2030	ADH2430	ADH2630	ADH2830	ADH21030	ADH3030	ADH3230	ADH3430	ADH3830	ADH4030	
3'-7 1/4" (1099)												
3'-11 1/4" (1200)	ADH1834	ADH2034	ADH2434	ADH2634	ADH2834	ADH21034	ADH3034	ADH3234	ADH3434	ADH3834	ADH4034	
4'-3 1/4" (1302)												
4'-7 1/4" (1403)	ADH1838	ADH2038	ADH2438	ADH2638	ADH2838	ADH21038	ADH3038	ADH3238	ADH3438	ADH3838	ADH4038	
4'-11 1/4" (1505)												
5'-3 1/4" (1607)	ADH1840	ADH2040	ADH2440	ADH2640	ADH2840	ADH21040	ADH3040	ADH3240	ADH3440	ADH3840	ADH4040	
5'-7 1/4" (1708)												
5'-11 1/4" (1810)	ADH1844	ADH2044	ADH2444	ADH2644	ADH2844	ADH21044	ADH3044	ADH3244	ADH3444	ADH3844	ADH4044	
6'-3 1/4" (1911)												
	ADH1848	ADH2048	ADH2448	ADH2648	ADH2848	ADH21048	ADH3048	ADH3248	ADH3448	ADH3848	ADH4048	
	ADH1850	ADH2050	ADH2450	ADH2650	ADH2850	ADH21050	ADH3050	ADH3250 <sup>o</sup>	ADH3450 <sup>o</sup>	ADH3850 <sup>o</sup>	ADH4050 <sup>o</sup>	
	ADH1854	ADH2054	ADH2454	ADH2654	ADH2854	ADH21054	ADH3054 <sup>o</sup>	ADH3254 <sup>o</sup>	ADH3454 <sup>o</sup>	ADH3854 <sup>o</sup>	ADH4054 <sup>o</sup>	
	ADH1858	ADH2058	ADH2458	ADH2658	ADH2858	ADH21058 <sup>o</sup>	ADH3058 <sup>o</sup>	ADH3258 <sup>o</sup>	ADH3458 <sup>o</sup>	ADH3858 <sup>o</sup>	ADH4058 <sup>o</sup>	
	ADH1860	ADH2060	ADH2460	ADH2660	ADH2860 <sup>o</sup>	ADH21060 <sup>o</sup>	ADH3060 <sup>o</sup>	ADH3260 <sup>o</sup>	ADH3460 <sup>o</sup>	ADH3860 <sup>o</sup>	ADH4060 <sup>o</sup>	
	ADH1864	ADH2064	ADH2464	ADH2664 <sup>o</sup>	ADH2864 <sup>o</sup>	ADH21064 <sup>o</sup>	ADH3064 <sup>o</sup>	ADH3264 <sup>o</sup>	ADH3464 <sup>o</sup>	ADH3864 <sup>o</sup>	ADH4064 <sup>o+</sup>	

continued on next page

**Table of Double-Hung Window Sizes** (continued)

Scale 1/8" (3) = 1'-0" (305) – 1:96

Unit Dimension	1'-7 1/4" (489)	1'-11 1/4" (591)	2'-3 1/4" (692)	2'-5 1/4" (743)	2'-7 1/4" (794)	2'-9 1/4" (845)	2'-11 1/4" (895)	3'-1 1/4" (946)	3'-3 1/4" (997)	3'-7 1/4" (1099)	3'-11 1/4" (1200)
<b>Minimum Rough Opening</b>	1'-8" (508)	2'-0" (610)	2'-4" (711)	2'-6" (762)	2'-8" (813)	2'-10" (864)	3'-0" (914)	3'-2" (965)	3'-4" (1016)	3'-8" (1118)	4'-0" (1219)
Unobstructed Glass (lower sash only)	12 5/8" (321)	16 5/8" (422)	20 5/8" (524)	22 5/8" (575)	24 5/8" (625)	26 5/8" (676)	28 5/8" (727)	30 5/8" (778)	32 5/8" (829)	36 5/8" (930)	40 5/8" (1031)

2:3 cottage or 3:2 reverse cottage sash ratio available for all standard widths and heights up to 6'-7 1/4" (2013). Custom sizes available. See page 61.

**CUSTOM SIZES AVAILABLE**

Window Height	ADH1868	ADH2068	ADH2468	ADH2668 <sup>o</sup>	ADH2868 <sup>o</sup>	ADH21068 <sup>o</sup>	ADH3068 <sup>o</sup>	ADH3268 <sup>o</sup>	ADH3468 <sup>o</sup>	ADH3868 <sup>o</sup>	ADH4068 <sup>o+</sup>
6'-7 1/4" (2013) 6'-8" (2032) 34 13/16" (884)											
7'-3 1/4" (2216) 7'-4" (2235) 38 13/16" (986)											
7'-11 1/4" (2419) 8'-0" (2438) 42 13/16" (1087)											

2:3 Cottage 3:2 Reverse Cottage



Custom-size windows are available in 1/8" (3) increments.

See page 61 for custom sizes and specifications.

Two locks are standard on all A-Series double-hung windows with Stormwatch® Protection.

Details and grille patterns shown on page 41.

• "Window Dimension" always refers to outside frame to frame dimension.  
 • "Minimum Rough Opening" dimensions may need to be increased to allow for use of building wraps, flashing, sill panning, brackets, fasteners or other items. See installation information on page 170.  
 • Dimensions in parentheses are in millimeters.  
<sup>o</sup>Equal sash ratio sizes that meet or exceed clear opening area of 5.7 sq. ft. or 0.53 m<sup>2</sup>, clear opening width of 20" (508) and clear opening height of 24"(610). See tables on pages 38-40.  
 +Limited sash travel.

## Double-Hung Window Opening and Area Specifications

Window Number	Clear Opening Area Sq. Ft./ (m <sup>2</sup> )	Clear Opening in Full Open Position		Glass Area Sq. Ft./ (m <sup>2</sup> )	Vent Area Sq. Ft./ (m <sup>2</sup> )	Top of Subfloor to Top of Inside Sill Stop Inches/ (mm)	Overall Window Area Sq. Ft./ (m <sup>2</sup> )
		Width Inches/ (mm)	Height Inches/ (mm)				
ADH1830	1.37 (0.13)	15 3/16" (386)	13" (330)	2.24 (1.38)	1.46 (0.14)	48 7/8" (1241)	4.71 (0.44)
ADH1834	1.58 (0.15)	15 3/16" (386)	15" (381)	2.59 (1.46)	1.67 (0.16)	44 7/8" (1140)	5.25 (0.49)
ADH1838	1.79 (0.17)	15 3/16" (386)	17" (432)	2.94 (1.63)	1.88 (0.17)	40 7/8" (1038)	5.78 (0.54)
ADH1840	2.00 (0.19)	15 3/16" (386)	19" (483)	3.29 (1.80)	2.09 (0.19)	36 7/8" (937)	6.32 (0.59)
ADH1844	2.21 (0.21)	15 3/16" (386)	21" (533)	3.64 (0.60)	2.30 (0.21)	32 7/8" (835)	6.85 (0.64)
ADH1848	2.42 (0.23)	15 3/16" (386)	23" (584)	3.99 (0.70)	2.51 (0.23)	28 7/8" (733)	7.39 (0.69)
ADH1850	2.64 (0.24)	15 3/16" (386)	25" (635)	4.34 (0.79)	2.72 (0.25)	24 7/8" (632)	7.92 (0.74)
ADH1854	2.85 (0.26)	15 3/16" (386)	27" (686)	4.69 (0.89)	2.94 (0.27)	20 7/8" (530)	8.46 (0.79)
ADH1858	3.06 (0.28)	15 3/16" (386)	29" (737)	5.04 (0.98)	3.15 (0.29)	16 7/8" (429)	8.99 (0.84)
ADH1860	3.27 (0.30)	15 3/16" (386)	31" (787)	5.39 (1.08)	3.36 (0.31)	12 7/8" (327)	9.52 (0.88)
ADH1864	3.48 (0.32)	15 3/16" (386)	33" (838)	5.74 (1.17)	3.56 (0.33)	8 7/8" (225)	10.06 (0.93)
ADH1868	3.69 (0.34)	15 3/16" (386)	35" (889)	6.09 (1.27)	3.78 (0.35)	4 7/8" (124)	10.59 (0.98)
ADH1874	4.11 (0.38)	15 3/16" (386)	39" (991)	6.79 (1.36)	4.20 (0.39)	10 3/8" (264)	11.66 (1.08)
ADH1880	4.53 (0.42)	15 3/16" (386)	43" (1092)	7.49 (1.45)	4.62 (0.43)	2 3/8" (60)	12.73 (1.18)
ADH2030	1.73 (0.16)	19 3/16" (487)	13" (330)	2.95 (1.55)	1.84 (0.17)	48 7/8" (1241)	5.69 (0.53)
ADH2034	2.00 (0.19)	19 3/16" (487)	15" (381)	3.41 (1.64)	2.11 (0.20)	44 7/8" (1140)	6.34 (0.59)
ADH2038	2.26 (0.21)	19 3/16" (487)	17" (432)	3.87 (1.83)	2.38 (0.22)	40 7/8" (1038)	6.98 (0.65)
ADH2040	2.53 (0.24)	19 3/16" (487)	19" (483)	4.33 (2.02)	2.64 (0.25)	36 7/8" (937)	7.63 (0.71)
ADH2044	2.80 (0.26)	19 3/16" (487)	21" (533)	4.80 (0.67)	2.91 (0.27)	32 7/8" (835)	8.27 (0.77)
ADH2048	3.06 (0.28)	19 3/16" (487)	23" (584)	5.26 (0.78)	3.18 (0.29)	28 7/8" (733)	8.92 (0.83)
ADH2050	3.33 (0.31)	19 3/16" (487)	25" (635)	5.72 (0.88)	3.44 (0.32)	24 7/8" (632)	9.57 (0.89)
ADH2054	3.60 (0.33)	19 3/16" (487)	27" (686)	6.18 (0.98)	3.71 (0.34)	20 7/8" (530)	10.21 (0.95)
ADH2058	3.86 (0.36)	19 3/16" (487)	29" (737)	6.64 (1.09)	3.98 (0.37)	16 7/8" (429)	10.86 (1.01)
ADH2060	4.13 (0.38)	19 3/16" (487)	31" (787)	7.10 (1.19)	4.24 (0.39)	12 7/8" (327)	11.50 (1.07)
ADH2064	4.40 (0.41)	19 3/16" (487)	33" (838)	7.56 (1.30)	4.50 (0.42)	8 7/8" (225)	12.15 (1.13)
ADH2068	4.66 (0.43)	19 3/16" (487)	35" (889)	8.02 (1.40)	4.77 (0.44)	4 7/8" (124)	12.80 (1.19)
ADH2074	5.20 (0.48)	19 3/16" (487)	39" (991)	8.95 (1.51)	5.30 (0.49)	10 3/8" (264)	14.09 (1.31)
ADH2080	5.73 (0.53)	19 3/16" (487)	43" (1092)	9.87 (1.61)	5.84 (0.54)	2 3/8" (60)	15.38 (1.43)
ADH2430	2.09 (0.19)	23 3/16" (589)	13" (330)	3.66 (1.72)	2.23 (0.21)	48 7/8" (1241)	6.67 (0.62)
ADH2434	2.41 (0.22)	23 3/16" (589)	15" (381)	4.24 (1.82)	2.55 (0.24)	44 7/8" (1140)	7.43 (0.69)
ADH2438	2.73 (0.25)	23 3/16" (589)	17" (432)	4.81 (2.03)	2.87 (0.27)	40 7/8" (1038)	8.18 (0.76)
ADH2440	3.06 (0.28)	23 3/16" (589)	19" (483)	5.38 (2.24)	3.19 (0.30)	36 7/8" (937)	8.94 (0.83)
ADH2444	3.38 (0.31)	23 3/16" (589)	21" (533)	5.95 (0.55)	3.51 (0.33)	32 7/8" (835)	9.70 (0.90)
ADH2448	3.70 (0.34)	23 3/16" (589)	23" (584)	6.52 (0.61)	3.84 (0.36)	28 7/8" (733)	10.46 (0.97)
ADH2450	4.02 (0.37)	23 3/16" (589)	25" (635)	7.10 (0.66)	4.16 (0.39)	24 7/8" (632)	11.21 (1.04)
ADH2454	4.35 (0.40)	23 3/16" (589)	27" (686)	7.67 (0.71)	4.48 (0.42)	20 7/8" (530)	11.97 (1.11)
ADH2458	4.67 (0.43)	23 3/16" (589)	29" (737)	8.24 (0.77)	4.80 (0.45)	16 7/8" (429)	12.73 (1.18)
ADH2460	4.99 (0.46)	23 3/16" (589)	31" (787)	8.81 (0.82)	5.13 (0.48)	12 7/8" (327)	13.48 (1.25)
ADH2464	5.31 (0.49)	23 3/16" (589)	33" (838)	9.39 (0.87)	5.44 (0.51)	8 7/8" (225)	14.24 (1.32)
ADH2468	5.63 (0.52)	23 3/16" (589)	35" (889)	9.96 (0.93)	5.76 (0.54)	4 7/8" (124)	15.00 (1.39)
ADH2474 ◊	6.28 (0.58)	23 3/16" (589)	39" (991)	11.10 (1.03)	6.41 (0.60)	10 3/8" (264)	16.51 (1.53)
ADH2480 ◊	6.92 (0.64)	23 3/16" (589)	43" (1092)	12.25 (1.14)	7.05 (0.66)	2 3/8" (60)	18.02 (1.67)
ADH2630	2.27 (0.21)	25 3/16" (640)	13" (330)	4.02 (0.37)	2.42 (0.22)	48 7/8" (1241)	7.16 (0.67)
ADH2634	2.62 (0.24)	25 3/16" (640)	15" (381)	4.65 (0.43)	2.77 (0.26)	44 7/8" (1140)	7.97 (0.74)
ADH2638	2.97 (0.28)	25 3/16" (640)	17" (432)	5.27 (0.49)	3.12 (0.29)	40 7/8" (1038)	8.79 (0.82)
ADH2640	3.32 (0.31)	25 3/16" (640)	19" (483)	5.90 (0.55)	3.47 (0.32)	36 7/8" (937)	9.60 (0.89)
ADH2644	3.67 (0.34)	25 3/16" (640)	21" (533)	6.53 (0.61)	3.82 (0.35)	32 7/8" (835)	10.41 (0.97)
ADH2648	4.02 (0.37)	25 3/16" (640)	23" (584)	7.16 (0.66)	4.17 (0.39)	28 7/8" (733)	11.22 (1.04)
ADH2650	4.37 (0.41)	25 3/16" (640)	25" (635)	7.79 (0.72)	4.52 (0.42)	24 7/8" (632)	12.04 (1.12)
ADH2654	4.72 (0.44)	25 3/16" (640)	27" (686)	8.41 (0.78)	4.87 (0.45)	20 7/8" (530)	12.85 (1.19)
ADH2658	5.07 (0.47)	25 3/16" (640)	29" (737)	9.04 (0.84)	5.22 (0.48)	16 7/8" (429)	13.66 (1.27)
ADH2660	5.42 (0.50)	25 3/16" (640)	31" (787)	9.67 (0.90)	5.57 (0.52)	12 7/8" (327)	14.47 (1.34)
ADH2664 ◊	5.77 (0.54)	25 3/16" (640)	33" (838)	10.30 (0.96)	5.91 (0.55)	8 7/8" (225)	15.29 (1.42)
ADH2668 ◊	6.12 (0.57)	25 3/16" (640)	35" (889)	10.92 (1.01)	6.26 (0.58)	4 7/8" (124)	16.10 (1.50)
ADH2674 ◊	6.82 (0.63)	25 3/16" (640)	39" (991)	12.18 (1.13)	6.96 (0.65)	10 3/8" (264)	17.72 (1.65)
ADH2680 ◊	7.52 (0.70)	25 3/16" (640)	43" (1092)	13.44 (1.25)	7.66 (0.71)	2 3/8" (60)	19.35 (1.80)
ADH2830	2.45 (0.23)	27 3/16" (691)	13" (330)	4.37 (0.41)	2.61 (0.24)	48 7/8" (1241)	7.65 (0.71)
ADH2834	2.83 (0.26)	27 3/16" (691)	15" (381)	5.06 (0.47)	2.99 (0.28)	44 7/8" (1140)	8.52 (0.79)

For cottage and reverse cottage sash ratio opening specifications, visit [andersenwindows.com/openingspecs](http://andersenwindows.com/openingspecs).

\* "Top of Subfloor to Top of Inside Sill Stop" is calculated based upon a structural header height of 6'-10 1/2" (2096) except for units greater than 81 3/4" (2076) in height which are calculated using a header height of 8' (2438).  
 \* Dimensions in parentheses are in millimeters or square meters.  
 ◊ Meet or exceed clear opening area of 5.7 sq. ft. or 0.53 m<sup>2</sup>, clear opening width of 20" (508) and clear opening height of 24" (610). continued on next page



**Double-Hung Window Opening and Area Specifications** *(continued)*

Window Number	Clear Opening Area Sq. Ft./ (m <sup>2</sup> )		Clear Opening in Full Open Position		Glass Area Sq. Ft./ (m <sup>2</sup> )	Vent Area Sq. Ft./ (m <sup>2</sup> )	Top of Subfloor to Top of Inside Sill Stop Inches/(mm)	Overall Window Area Sq. Ft./ (m <sup>2</sup> )
			Width Inches/(mm)	Height Inches/(mm)				
ADH2838	3.21 (0.30)	27 3/16" (691)	17" (432)	5.74 (0.53)	3.37 (0.31)	40 7/8" (1038)	9.39 (0.87)	
ADH2840	3.58 (0.33)	27 3/16" (691)	19" (483)	6.42 (0.60)	3.74 (0.35)	36 7/8" (937)	10.25 (0.95)	
ADH2844	3.96 (0.37)	27 3/16" (691)	21" (533)	7.11 (0.66)	4.12 (0.38)	32 7/8" (835)	11.12 (1.03)	
ADH2848	4.34 (0.40)	27 3/16" (691)	23" (584)	7.79 (0.72)	4.50 (0.42)	28 7/8" (733)	11.99 (1.11)	
ADH2850	4.72 (0.44)	27 3/16" (691)	25" (635)	8.47 (0.79)	4.88 (0.45)	24 7/8" (632)	12.86 (1.19)	
ADH2854	5.10 (0.47)	27 3/16" (691)	27" (686)	9.16 (0.85)	5.25 (0.49)	20 7/8" (530)	13.73 (1.28)	
ADH2858	5.47 (0.51)	27 3/16" (691)	29" (737)	9.84 (0.91)	5.63 (0.52)	16 7/8" (429)	14.59 (1.36)	
ADH2860 ◊	5.85 (0.54)	27 3/16" (691)	31" (787)	10.52 (0.98)	6.01 (0.56)	12 7/8" (327)	15.46 (1.44)	
ADH2864 ◊	6.23 (0.58)	27 3/16" (691)	33" (838)	11.21 (1.04)	6.38 (0.59)	8 7/8" (225)	16.33 (1.52)	
ADH2868 ◊	6.61 (0.61)	27 3/16" (691)	35" (889)	11.89 (1.10)	6.76 (0.63)	4 7/8" (124)	17.20 (1.60)	
ADH2874 ◊	7.36 (0.68)	27 3/16" (691)	39" (991)	13.26 (1.23)	7.51 (0.70)	10 3/8" (264)	18.93 (1.76)	
ADH2880 ◊	8.12 (0.75)	27 3/16" (691)	43" (1092)	14.62 (1.36)	8.27 (0.77)	2 3/8" (60)	20.67 (1.92)	
ADH21030	2.63 (0.24)	29 3/16" (741)	13" (330)	4.73 (0.44)	2.80 (0.26)	48 7/8" (1241)	8.14 (0.76)	
ADH21034	3.04 (0.28)	29 3/16" (741)	15" (381)	5.47 (0.51)	3.21 (0.30)	44 7/8" (1140)	9.06 (0.84)	
ADH21038	3.44 (0.32)	29 3/16" (741)	17" (432)	6.21 (0.58)	3.61 (0.34)	40 7/8" (1038)	9.99 (0.93)	
ADH21040	3.85 (0.36)	29 3/16" (741)	19" (483)	6.95 (0.65)	4.02 (0.37)	36 7/8" (937)	10.91 (1.01)	
ADH21044	4.25 (0.40)	29 3/16" (741)	21" (533)	7.69 (0.71)	4.42 (0.41)	32 7/8" (835)	11.83 (1.10)	
ADH21048	4.66 (0.43)	29 3/16" (741)	23" (584)	8.42 (0.78)	4.83 (0.45)	28 7/8" (733)	12.76 (1.19)	
ADH21050	5.06 (0.47)	29 3/16" (741)	25" (635)	9.16 (0.85)	5.24 (0.49)	24 7/8" (632)	13.68 (1.27)	
ADH21054	5.47 (0.51)	29 3/16" (741)	27" (686)	9.90 (0.92)	5.64 (0.52)	20 7/8" (530)	14.60 (1.36)	
ADH21058 ◊	5.88 (0.55)	29 3/16" (741)	29" (737)	10.64 (0.99)	6.05 (0.56)	16 7/8" (429)	15.53 (1.44)	
ADH21060 ◊	6.28 (0.58)	29 3/16" (741)	31" (787)	11.38 (1.06)	6.45 (0.60)	12 7/8" (327)	16.45 (1.53)	
ADH21064 ◊	6.69 (0.62)	29 3/16" (741)	33" (838)	12.12 (1.13)	6.85 (0.64)	8 7/8" (225)	17.38 (1.61)	
ADH21068 ◊	7.09 (0.66)	29 3/16" (741)	35" (889)	12.86 (1.19)	7.25 (0.67)	4 7/8" (124)	18.30 (1.70)	
ADH21074 ◊	7.90 (0.73)	29 3/16" (741)	39" (991)	14.34 (1.33)	8.07 (0.75)	10 3/8" (264)	20.15 (1.87)	
ADH21080 ◊	8.71 (0.81)	29 3/16" (741)	43" (1092)	15.81 (1.47)	8.88 (0.82)	2 3/8" (60)	21.99 (2.04)	
ADH3030	2.81 (0.26)	31 3/16" (792)	13" (330)	5.09 (0.47)	2.99 (0.28)	48 7/8" (1241)	8.63 (0.80)	
ADH3034	3.25 (0.30)	31 3/16" (792)	15" (381)	5.88 (0.55)	3.43 (0.32)	44 7/8" (1140)	9.61 (0.89)	
ADH3038	3.68 (0.34)	31 3/16" (792)	17" (432)	6.67 (0.62)	3.86 (0.36)	40 7/8" (1038)	10.59 (0.98)	
ADH3040	4.11 (0.38)	31 3/16" (792)	19" (483)	7.47 (0.69)	4.29 (0.40)	36 7/8" (937)	11.57 (1.07)	
ADH3044	4.54 (0.42)	31 3/16" (792)	21" (533)	8.26 (0.77)	4.73 (0.44)	32 7/8" (835)	12.55 (1.17)	
ADH3048	4.98 (0.46)	31 3/16" (792)	23" (584)	9.06 (0.84)	5.16 (0.48)	28 7/8" (733)	13.52 (1.26)	
ADH3050	5.41 (0.50)	31 3/16" (792)	25" (635)	9.85 (0.92)	5.59 (0.52)	24 7/8" (632)	14.50 (1.35)	
ADH3054 ◊	5.84 (0.54)	31 3/16" (792)	27" (686)	10.65 (0.99)	6.03 (0.56)	20 7/8" (530)	15.48 (1.44)	
ADH3058 ◊	6.28 (0.58)	31 3/16" (792)	29" (737)	11.44 (1.06)	6.46 (0.60)	16 7/8" (429)	16.46 (1.53)	
ADH3060 ◊	6.71 (0.62)	31 3/16" (792)	31" (787)	12.24 (1.14)	6.89 (0.64)	12 7/8" (327)	17.44 (1.62)	
ADH3064 ◊	7.14 (0.66)	31 3/16" (792)	33" (838)	13.03 (1.21)	7.32 (0.68)	8 7/8" (225)	18.42 (1.71)	
ADH3068 ◊	7.58 (0.70)	31 3/16" (792)	35" (889)	13.82 (1.28)	7.75 (0.72)	4 7/8" (124)	19.40 (1.80)	
ADH3074 ◊	8.44 (0.78)	31 3/16" (792)	39" (991)	15.41 (1.43)	8.62 (0.80)	10 3/8" (264)	21.36 (1.98)	
ADH3080 ◊	9.31 (0.86)	31 3/16" (792)	43" (1092)	17.00 (1.58)	9.48 (0.88)	2 3/8" (60)	23.32 (2.17)	
ADH3230	2.99 (0.28)	33 3/16" (843)	13" (330)	5.44 (0.51)	3.19 (0.30)	48 7/8" (1241)	9.12 (0.85)	
ADH3234	3.45 (0.32)	33 3/16" (843)	15" (381)	6.29 (0.58)	3.65 (0.34)	44 7/8" (1140)	10.15 (0.94)	
ADH3238	3.91 (0.36)	33 3/16" (843)	17" (432)	7.14 (0.66)	4.11 (0.38)	40 7/8" (1038)	11.19 (1.04)	
ADH3240	4.38 (0.41)	33 3/16" (843)	19" (483)	7.99 (0.74)	4.57 (0.42)	36 7/8" (937)	12.22 (1.14)	
ADH3244	4.84 (0.45)	33 3/16" (843)	21" (533)	8.84 (0.82)	5.03 (0.47)	32 7/8" (835)	13.26 (1.23)	
ADH3248	5.30 (0.49)	33 3/16" (843)	23" (584)	9.69 (0.90)	5.49 (0.51)	28 7/8" (733)	14.29 (1.33)	
ADH3250 ◊	5.76 (0.53)	33 3/16" (843)	25" (635)	10.54 (0.98)	5.95 (0.55)	24 7/8" (632)	15.33 (1.42)	
ADH3254 ◊	6.22 (0.58)	33 3/16" (843)	27" (686)	11.39 (1.06)	6.41 (0.60)	20 7/8" (530)	16.36 (1.52)	
ADH3258 ◊	6.68 (0.62)	33 3/16" (843)	29" (737)	12.24 (1.14)	6.87 (0.64)	16 7/8" (429)	17.40 (1.62)	
ADH3260 ◊	7.14 (0.66)	33 3/16" (843)	31" (787)	13.09 (1.22)	7.34 (0.68)	12 7/8" (327)	18.43 (1.71)	
ADH3264 ◊	7.60 (0.71)	33 3/16" (843)	33" (838)	13.94 (1.30)	7.79 (0.72)	8 7/8" (225)	19.47 (1.81)	
ADH3268 ◊	8.06 (0.75)	33 3/16" (843)	35" (889)	14.79 (1.37)	8.25 (0.77)	4 7/8" (124)	20.50 (1.90)	
ADH3274 ◊	8.99 (0.83)	33 3/16" (843)	39" (991)	16.49 (1.53)	9.17 (0.85)	10 3/8" (264)	22.57 (2.10)	
ADH3280*	5.65 (0.52)	33 3/16" (843)	24 1/2" (622)	18.19 (1.69)	10.09 (0.94)	2 3/8" (60)	24.64 (2.29)	
ADH3430	3.17 (0.29)	35 3/16" (894)	13" (330)	5.80 (0.54)	3.38 (0.31)	48 7/8" (1241)	9.61 (0.89)	
ADH3434	3.66 (0.34)	35 3/16" (894)	15" (381)	6.70 (0.62)	3.87 (0.36)	44 7/8" (1140)	10.70 (0.99)	
ADH3438	4.15 (0.39)	35 3/16" (894)	17" (432)	7.61 (0.71)	4.36 (0.40)	40 7/8" (1038)	11.79 (1.10)	

For cottage and reverse cottage sash ratio opening specifications, visit [andersenwindows.com/openingspecs](http://andersenwindows.com/openingspecs).

A-Series Double-Hung Windows

\*Top of Subfloor to Top of Inside Sill Stop\* is calculated based upon a structural header height of 6'-10 1/2" (2096) except for units greater than 81 3/4" (2076) in height which are calculated using a header height of 8' (2438).  
 ◊Meet or exceed clear opening area of 5.7 sq. ft. or 0.53 m<sup>2</sup>, clear opening width of 20" (508) and clear opening height of 24" (610).  
 \*Limited sash travel. *continued on next page*

## Double-Hung Window Opening and Area Specifications (continued)

Window Number	Clear Opening Area Sq. Ft./ (m <sup>2</sup> )		Clear Opening in Full Open Position		Glass Area Sq. Ft./ (m <sup>2</sup> )	Vent Area Sq. Ft./ (m <sup>2</sup> )	Top of Subfloor to Top of Inside Sill Stop Inches/ (mm)	Overall Window Area Sq. Ft./ (m <sup>2</sup> )
			Width Inches/ (mm)	Height Inches/ (mm)				
ADH3440	4.64	(0.43)	35 3/16" (894)	19" (483)	8.51 (0.79)	4.84 (0.45)	36 7/8" (937)	12.88 (1.20)
ADH3444	5.13	(0.48)	35 3/16" (894)	21" (533)	9.42 (0.87)	5.33 (0.50)	32 7/8" (835)	13.97 (1.30)
ADH3448	5.62	(0.52)	35 3/16" (894)	23" (584)	10.32 (0.96)	5.82 (0.54)	28 7/8" (733)	15.06 (1.40)
ADH3450 ◊	6.11	(0.57)	35 3/16" (894)	25" (635)	11.23 (1.04)	6.31 (0.59)	24 7/8" (632)	16.15 (1.50)
ADH3454 ◊	6.59	(0.61)	35 3/16" (894)	27" (686)	12.14 (1.13)	6.80 (0.63)	20 7/8" (530)	17.24 (1.60)
ADH3458 ◊	7.08	(0.66)	35 3/16" (894)	29" (737)	13.04 (1.21)	7.29 (0.68)	16 7/8" (429)	18.33 (1.70)
ADH3460 ◊	7.57	(0.70)	35 3/16" (894)	31" (787)	13.95 (1.30)	7.78 (0.72)	12 7/8" (327)	19.42 (1.80)
ADH3464 ◊	8.06	(0.75)	35 3/16" (894)	33" (838)	14.85 (1.38)	8.26 (0.77)	8 7/8" (225)	20.51 (1.91)
ADH3468 ◊	8.55	(0.79)	35 3/16" (894)	35" (889)	15.76 (1.46)	8.74 (0.81)	4 7/8" (124)	21.60 (2.01)
ADH3474 ◊	9.53	(0.89)	35 3/16" (894)	39" (991)	17.57 (1.63)	9.72 (0.90)	10 3/8" (264)	23.78 (2.21)
ADH3480 ◊+	5.99	(0.56)	35 3/16" (894)	24 1/2" (622)	19.38 (1.80)	10.70 (0.99)	2 3/8" (60)	25.96 (2.41)
ADH3830	3.53	(0.33)	39 3/16" (995)	13" (330)	6.51 (0.60)	3.76 (0.35)	48 7/8" (1241)	10.59 (0.98)
ADH3834	4.08	(0.38)	39 3/16" (995)	15" (381)	7.52 (0.70)	4.31 (0.40)	44 7/8" (1140)	11.79 (1.10)
ADH3838	4.62	(0.43)	39 3/16" (995)	17" (432)	8.54 (0.79)	4.85 (0.45)	40 7/8" (1038)	12.99 (1.21)
ADH3840	5.17	(0.48)	39 3/16" (995)	19" (483)	9.56 (0.89)	5.40 (0.50)	36 7/8" (937)	14.19 (1.32)
ADH3844	5.71	(0.53)	39 3/16" (995)	21" (533)	10.57 (0.98)	5.94 (0.55)	32 7/8" (835)	15.39 (1.43)
ADH3848	6.25	(0.58)	39 3/16" (995)	23" (584)	11.59 (1.08)	6.48 (0.60)	28 7/8" (733)	16.59 (1.54)
ADH3850 ◊	6.80	(0.63)	39 3/16" (995)	25" (635)	12.61 (1.17)	7.03 (0.65)	24 7/8" (632)	17.80 (1.65)
ADH3854 ◊	7.34	(0.68)	39 3/16" (995)	27" (686)	13.62 (1.27)	7.57 (0.70)	20 7/8" (530)	19.00 (1.77)
ADH3858 ◊	7.89	(0.73)	39 3/16" (995)	29" (737)	14.64 (1.36)	8.12 (0.75)	16 7/8" (429)	20.20 (1.88)
ADH3860 ◊	8.43	(0.78)	39 3/16" (995)	31" (787)	15.66 (1.45)	8.66 (0.80)	12 7/8" (327)	21.40 (1.99)
ADH3864 ◊	8.98	(0.83)	39 3/16" (995)	33" (838)	16.67 (1.55)	9.19 (0.85)	8 7/8" (225)	22.60 (2.10)
ADH3868 ◊	9.52	(0.88)	39 3/16" (995)	39" (991)	17.69 (1.64)	9.74 (0.90)	4 7/8" (124)	23.80 (2.21)
ADH3874 ◊+	6.67	(0.62)	39 3/16" (995)	24 1/2" (622)	19.72 (1.83)	10.83 (1.01)	10 3/8" (264)	26.21 (2.43)
ADH3880 ◊+	6.67	(0.62)	39 3/16" (995)	24 1/2" (622)	21.76 (2.02)	11.92 (1.11)	2 3/8" (60)	28.61 (2.66)
ADH4030	3.89	(0.36)	43 3/16" (1097)	13" (330)	7.22 (0.67)	4.15 (0.39)	48 7/8" (1241)	11.57 (1.07)
ADH4034	4.49	(0.42)	43 3/16" (1097)	15" (381)	8.35 (0.78)	4.75 (0.44)	44 7/8" (1140)	12.88 (1.20)
ADH4038	5.09	(0.47)	43 3/16" (1097)	17" (432)	9.47 (0.88)	5.35 (0.50)	40 7/8" (1038)	14.19 (1.32)
ADH4040	5.69	(0.53)	43 3/16" (1097)	19" (483)	10.60 (0.98)	5.95 (0.55)	36 7/8" (937)	15.50 (1.44)
ADH4044	6.29	(0.58)	43 3/16" (1097)	21" (533)	11.73 (1.09)	6.55 (0.61)	32 7/8" (835)	16.82 (1.56)
ADH4048	6.89	(0.64)	43 3/16" (1097)	23" (584)	12.86 (1.19)	7.15 (0.66)	28 7/8" (733)	18.13 (1.68)
ADH4050 ◊	7.49	(0.70)	43 3/16" (1097)	25" (635)	13.99 (1.30)	7.75 (0.72)	24 7/8" (632)	19.44 (1.81)
ADH4054 ◊	8.09	(0.75)	43 3/16" (1097)	27" (686)	15.11 (1.40)	8.35 (0.78)	20 7/8" (530)	20.75 (1.93)
ADH4058 ◊	8.69	(0.81)	43 3/16" (1097)	29" (737)	16.24 (1.51)	8.95 (0.83)	16 7/8" (429)	22.07 (2.05)
ADH4060 ◊	9.29	(0.86)	43 3/16" (1097)	31" (787)	17.37 (1.61)	9.55 (0.89)	12 7/8" (327)	23.38 (2.17)
ADH4064 ◊+	7.35	(0.68)	43 3/16" (1097)	24 1/2" (622)	18.50 (1.72)	10.13 (0.94)	8 7/8" (225)	24.96 (2.32)
ADH4068 ◊+	7.35	(0.68)	43 3/16" (1097)	24 1/2" (622)	19.62 (1.82)	10.73 (1.00)	4 7/8" (124)	26.00 (2.42)
ADH4074 ◊+	7.35	(0.68)	43 3/16" (1097)	24 1/2" (622)	21.88 (2.03)	11.93 (1.11)	10 3/8" (264)	28.63 (2.66)
ADH4080 ◊+	7.35	(0.68)	43 3/16" (1097)	24 1/2" (622)	24.14 (2.24)	13.13 (1.22)	2 3/8" (60)	31.25 (2.90)

For cottage and reverse cottage sash ratio opening specifications, visit [andersenwindows.com/openingspecs](http://andersenwindows.com/openingspecs).

\*"Top of Subfloor to Top of Inside Sill Stop" is calculated based upon a structural header height of 6'-10 1/2" (2096) except for units greater than 81 3/4" (2076) in height which are calculated using a header height of 8' (2438).

\* Dimensions in parentheses are in millimeters or square meters.

◊ Meet or exceed clear opening area of 5.7 sq. ft. or 0.53 m<sup>2</sup>, clear opening width of 20" (508) and clear opening height of 24" (610).

+ Limited sash travel.

**Grille Patterns**

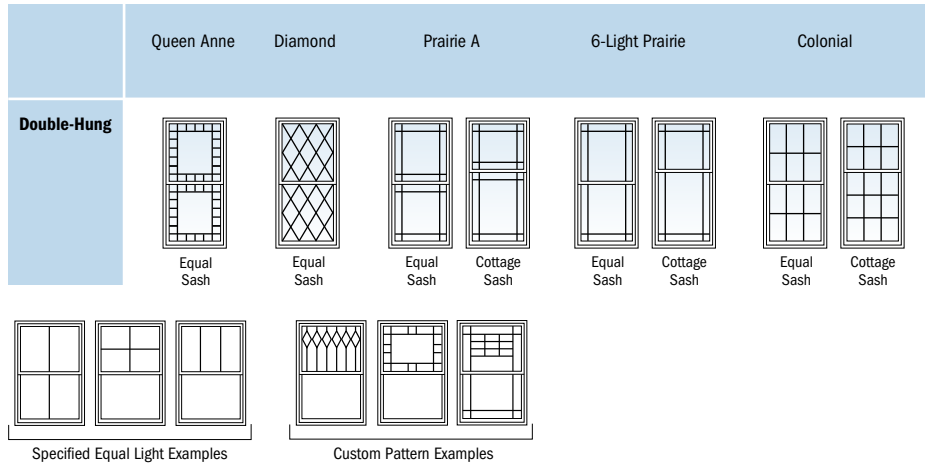

Double-hung grille patterns are also available in Upper Sash Only (USO) configurations. For picture window patterns that require alignment with double-hung patterns, identify the double-hung sash style (equal, cottage or reverse cottage sash ratio) when ordering. **Number of lights and overall pattern varies with window size.**

**Patterns shown may not be available for all sizes.**

Specified equal light and custom patterns are also available. Some restrictions apply. For more information on divided light, see page 15 or visit [andersenwindows.com/grilles](http://andersenwindows.com/grilles).

A-Series Double-Hung Windows

**Double-Hung Window Details**

Scale 1 1/2" (38) = 1'-0" (305) – 1:8

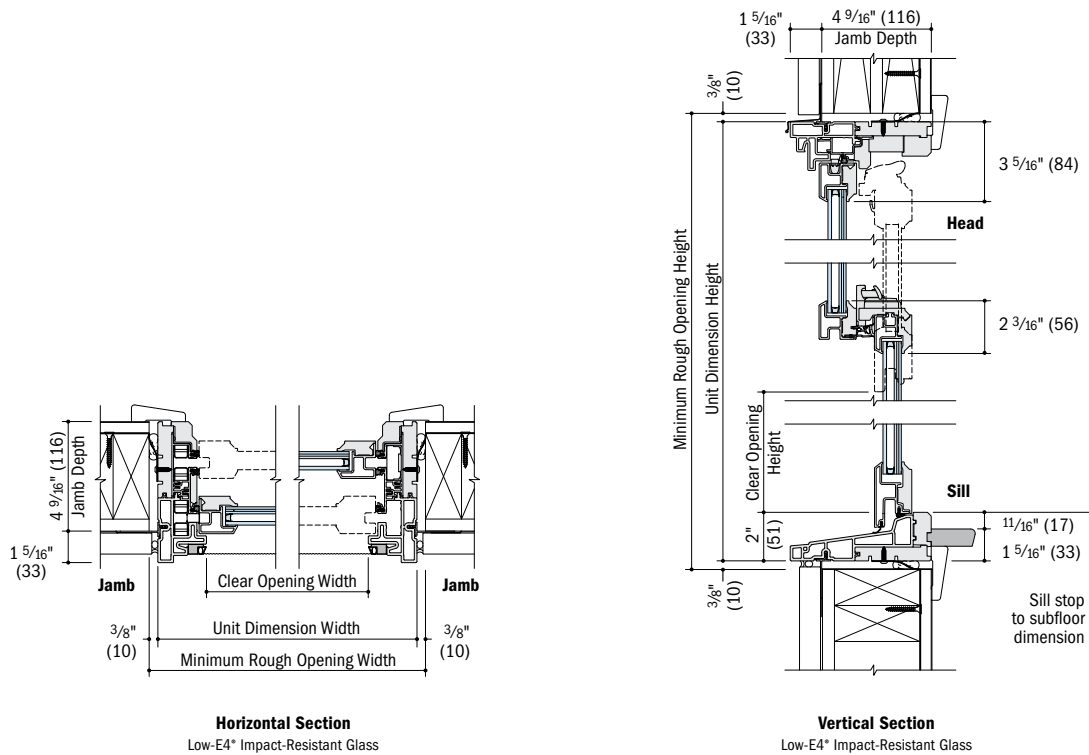

See pages 57-59 for horizontal and vertical joining details.

- 4 9/16" (116) jamb depth measurement is from back side of installation flange.
- Light-colored areas are parts included with window. Dark-colored areas are additional Andersen® parts required to complete window assembly as shown.
- Dimensions in parentheses are in millimeters.
- **Minimum rough opening dimensions may need to be increased to allow for use of building wraps, flashing, sill panning, brackets, fasteners or other items. See installation information on page 170.**
- Details are for illustration only and are not intended to represent product installation methods or materials. Refer to product installation guides at [andersenwindows.com](http://andersenwindows.com).

## Table of Picture Window Sizes

Scale 1/8" (3) = 1'-0" (305) – 1:96

Notes on the next page also apply to this page.

Window Dimension	1'-3 1/4"	1'-7 1/4"	1'-11 1/4"	2'-3 1/4"	2'-5 1/4"	2'-7 1/4"	2'-9 1/4"	2'-11 1/4"	3'-1 1/4"	3'-3 1/4"	3'-7 1/4"	3'-11 1/4"
	(387)	(489)	(591)	(692)	(743)	(794)	(845)	(895)	(946)	(997)	(1099)	(1200)
<b>Minimum Rough Opening</b>	1'-4"	1'-8"	2'-0"	2'-4"	2'-6"	2'-8"	2'-10"	3'-0"	3'-2"	3'-4"	3'-8"	4'-0"
	(406)	(508)	(610)	(711)	(762)	(813)	(864)	(914)	(965)	(1016)	(1118)	(1219)
Unobstructed Glass	8 5/8"	12 5/8"	16 5/8"	20 5/8"	22 5/8"	24 5/8"	26 5/8"	28 5/8"	30 5/8"	32 5/8"	36 5/8"	40 5/8"
	(219)	(321)	(422)	(524)	(575)	(625)	(676)	(727)	(778)	(829)	(930)	(1032)

### CUSTOM SIZES AVAILABLE

Window Dimension	1'-11 1/4"	2'-3 1/4"	2'-7 1/4"	2'-11 1/4"	3'-3 1/4"	3'-7 1/4"	3'-11 1/4"	4'-3 1/4"	4'-7 1/4"	4'-11 1/4"	5'-3 1/4"	5'-7 1/4"	5'-11 1/4"
	(591)	(692)	(794)	(895)	(997)	(1099)	(1200)	(1302)	(1403)	(1505)	(1607)	(1708)	(1810)
	2'-0"	2'-4"	2'-8"	3'-0"	3'-4"	3'-8"	4'-0"	4'-4"	4'-8"	5'-0"	5'-4"	5'-8"	6'-0"
	(610)	(711)	(813)	(914)	(1016)	(1118)	(1219)	(1321)	(1422)	(1524)	(1626)	(1727)	(1829)
	15 13/16"	19 13/16"	23 13/16"	27 13/16"	31 13/16"	35 13/16"	39 13/16"	43 13/16"	47 13/16"	51 13/16"	55 13/16"	59 13/16"	63 13/16"
	(401)	(503)	(604)	(706)	(808)	(910)	(1011)	(1113)	(1214)	(1316)	(1418)	(1519)	(1621)
<b>CUSTOM SIZES AVAILABLE</b>													
APW1420	APW1820	APW2020	APW2420	APW2620	APW2820	APW21020	APW3020	APW3220	APW3420	APW3820	APW4020		
APW1424	APW1824	APW2024	APW2424	APW2624	APW2824	APW21024	APW3024	APW3224	APW3424	APW3824	APW4024		
APW1428	APW1828	APW2028	APW2428	APW2628	APW2828	APW21028	APW3028	APW3228	APW3428	APW3828	APW4028		
APW1430	APW1830	APW2030	APW2430	APW2630	APW2830	APW21030	APW3030	APW3230	APW3430	APW3830	APW4030		
APW1434	APW1834	APW2034	APW2434	APW2634	APW2834	APW21034	APW3034	APW3234	APW3434	APW3834	APW4034		
APW1438	APW1838	APW2038	APW2438	APW2638	APW2838	APW21038	APW3038	APW3238	APW3438	APW3838	APW4038		
APW1440	APW1840	APW2040	APW2440	APW2640	APW2840	APW21040	APW3040	APW3240	APW3440	APW3840	APW4040		
APW1444	APW1844	APW2044	APW2444	APW2644	APW2844	APW21044	APW3044	APW3244	APW3444	APW3844	APW4044		
APW1448	APW1848	APW2048	APW2448	APW2648	APW2848	APW21048	APW3048	APW3248	APW3448	APW3848	APW4048		
APW1450	APW1850	APW2050	APW2450	APW2650	APW2850	APW21050	APW3050	APW3250	APW3450	APW3850	APW4050		
APW1454	APW1854	APW2054	APW2454	APW2654	APW2854	APW21054	APW3054	APW3254	APW3454	APW3854	APW4054		
APW1458	APW1858	APW2058	APW2458	APW2658	APW2858	APW21058	APW3058	APW3258	APW3458	APW3858	APW4058		
APW1460	APW1860	APW2060	APW2460	APW2660	APW2860	APW21060	APW3060	APW3260	APW3460	APW3860	APW4060		

Picture sizes on pages 42-46.

4'-3 1/4" (1302)	4'-7 1/4" (1403)	4'-11 1/4" (1505)	5'-3 1/4" (1607)	5'-7 1/4" (1708)	5'-11 1/4" (1810)	6'-3 1/4" (1911)
4'-4" (1321)	4'-8" (1422)	5'-0" (1524)	5'-4" (1626)	5'-8" (1727)	6'-0" (1829)	6'-4" (1930)
44 5/8" (1133)	48 5/8" (1235)	52 5/8" (1337)	56 5/8" (1438)	60 5/8" (1540)	64 5/8" (1641)	68 5/8" (1743)

 APW4420	 APW4820	 APW5020	 APW5420	 APW5820	 APW6020	 APW6420
 APW4424	 APW4824	 APW5024	 APW5424	 APW5824	 APW6024	 APW6424
 APW4428	 APW4828	 APW5028	 APW5428	 APW5828	 APW6028	 APW6428
 APW4430	 APW4830	 APW5030	 APW5430	 APW5830	 APW6030	 APW6430
 APW4434	 APW4834	 APW5034	 APW5434	 APW5834	 APW6034	 APW6434
 APW4438	 APW4838	 APW5038	 APW5438	 APW5838	 APW6038	 APW6438
 APW4440	 APW4840	 APW5040	 APW5440	 APW5840	 APW6040	 APW6440
 APW4444	 APW4844	 APW5044	 APW5444	 APW5844	 APW6044	 APW6444
 APW4448	 APW4848	 APW5048	 APW5448	 APW5848	 APW6048	 APW6448
 APW4450	 APW4850	 APW5050	 APW5450	 APW5850	 APW6050	 APW6450
 APW4454	 APW4854	 APW5054	 APW5454	 APW5854	 APW6054	 APW6454
 APW4458	 APW4858	 APW5058	 APW5458	 APW5858	 APW6058	 APW6458
 APW4460	 APW4860	 APW5060	 APW5460	 APW5860	 APW6060	 APW6460



Custom-size windows are available in 1/8" (3) increments. See page 62 for custom sizes and specifications.

**Picture window must be installed as shown and should not be rotated.** Tall bottom rail is designed to align with bottom rail of double-hung and casement windows.

Details shown on page 49.  
Grille patterns shown on page 45.

\* "Window Dimension" always refers to outside frame to frame dimension.  
\* "Minimum Rough Opening" dimensions may need to be increased to allow for use of building wraps, flashing, sill panning, brackets, fasteners or other items. See installation information on page 170.  
\* Dimensions in parentheses are in millimeters.

continued on next page

**Table of Picture Window Sizes** (continued)

Notes on the next page also apply to this page.

Scale 1/8" (3) = 1'-0" (305) – 1:96

Window Dimension	1'-3 1/4"	1'-7 1/4"	1'-11 1/4"	2'-3 1/4"	2'-5 1/4"	2'-7 1/4"	2'-9 1/4"	2'-11 1/4"	3'-1 1/4"	3'-3 1/4"	3'-7 1/4"	3'-11 1/4"
	(387)	(489)	(591)	(692)	(743)	(794)	(845)	(895)	(946)	(997)	(1099)	(1200)
<b>Minimum Rough Opening</b>	1'-4"	1'-8"	2'-0"	2'-4"	2'-6"	2'-8"	2'-10"	3'-0"	3'-2"	3'-4"	3'-8"	4'-0"
	(406)	(508)	(610)	(711)	(762)	(813)	(864)	(914)	(965)	(1016)	(1118)	(1219)
Unobstructed Glass	8 5/8"	12 5/8"	16 5/8"	20 5/8"	22 5/8"	24 5/8"	26 5/8"	28 5/8"	30 5/8"	32 5/8"	36 5/8"	40 5/8"
	(219)	(321)	(422)	(524)	(575)	(625)	(676)	(727)	(778)	(829)	(930)	(1032)

**CUSTOM SIZES AVAILABLE**

Window Dimension	1'-3 1/4"	1'-7 1/4"	1'-11 1/4"	2'-3 1/4"	2'-5 1/4"	2'-7 1/4"	2'-9 1/4"	2'-11 1/4"	3'-1 1/4"	3'-3 1/4"	3'-7 1/4"	3'-11 1/4"
6'-3 1/4" (1911)	6'-4" (1930)	6'-7 1/4" (2013)	6'-8" (2032)	7'-4" (2235)	8'-0" (2438)	87 13/16" (2230)						
	67 13/16" (1722)	71 13/16" (1824)	79 13/16" (2027)									
	APW1464	APW1864	APW2064	APW2464	APW2664	APW2864	APW21064	APW3064	APW3264	APW3464	APW3864	APW4064
	APW1468	APW1868	APW2068	APW2468	APW2668	APW2868	APW21068	APW3068	APW3268	APW3468	APW3868	APW4068
	APW1474	APW1874	APW2074	APW2474	APW2674	APW2874	APW21074	APW3074	APW3274	APW3474	APW3874	APW4074
	APW1480	APW1880	APW2080	APW2480	APW2680	APW2880	APW21080	APW3080	APW3280	APW3480	APW3880	APW4080

\* "Window Dimension" always refers to outside frame to frame dimension.  
 • "Minimum Rough Opening" dimensions may need to be increased to allow for use of building wraps, flashing, sill panning, brackets, fasteners or other items. See installation information on page 170.  
 • Dimensions in parentheses are in millimeters.

Picture sizes on pages 42-46.

4'-3 1/4" (1302)	4'-7 1/4" (1403)	4'-11 1/4" (1505)	5'-3 1/4" (1607)	5'-7 1/4" (1708)	5'-11 1/4" (1810)
4'-4" (1321)	4'-8" (1422)	5'-0" (1524)	5'-4" (1626)	5'-8" (1727)	6'-0" (1829)
44 5/8" (1133)	48 5/8" (1235)	52 5/8" (1337)	56 5/8" (1438)	60 5/8" (1540)	64 5/8" (1641)



Custom-size windows are available in 1/8" (3) increments. See page 62 for custom sizes and specifications.

**Picture window must be installed as shown and should not be rotated.**

Tall bottom rail is designed to align with bottom rail of double-hung and casement windows.

Details shown on page 49.

Grille patterns shown below.



*continued on next page*

- \*"Window Dimension" always refers to outside frame to frame dimension.
- \*\*"Minimum Rough Opening" dimensions may need to be increased to allow for use of building wraps, flashing, sill panning, brackets, fasteners or other items. See installation information on page 170.
- \*Dimensions in parentheses are in millimeters.
- \*Tempered laminated glass required. Some visual distortion may occur.

**Grille Patterns**

	Queen Anne	Diamond	Prairie A	Specified Equal Light with Simulated Check Rail	Colonial	Modified Colonial	Modified Colonial with Simulated Check Rail	Tall Fractional	Tall Fractional with Simulated Check Rail	Short Fractional	Short Fractional with Simulated Check Rail
Picture											

\*Andersen® Finelight™ grilles available in 3/4" (19) profile only.

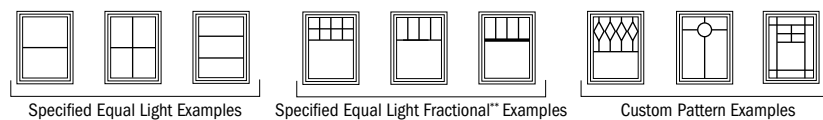

\*\*Daylight opening dimensions are available at 8" (203), 10" (254), 12" (305), center and custom dimensions.

For picture window patterns that require alignment with double-hung patterns, identify the double-hung sash style (equal, cottage, reverse cottage sash ratio) when ordering. **Number of lights and overall pattern varies with window size. Patterns shown may not be available for all sizes.** Specified equal light and custom patterns are also available. For more information on divided light, see page 15 or visit [andersenwindows.com/grilles](http://andersenwindows.com/grilles).

**Table of Picture Window Sizes** (continued)  
Scale 1/8" (3) = 1'-0" (305) – 1:96

Picture sizes on pages 42-46.

Window Dimension	6'-7 1/4" (2013)	6'-11 1/4" (2115)	7'-3 1/4" (2216)	7'-7 1/4" (2318)	7'-11 1/4" (2419)
<b>Minimum Rough Opening</b>	6'-8" (2032)	7'-0" (2133)	7'-4" (2235)	7'-8" (2336)	8'-0" (2438)
Unobstructed Glass	72 5/8" (1845)	76 5/8" (1946)	80 5/8" (2048)	84 5/8" (2149)	88 5/8" (2251)

CUSTOM SIZES AVAILABLE						
1'-11 1/4" (591)	2'-0" (610)	APW6820	APW7020	APW7420	APW7820	APW8020
2'-3 1/4" (692)	2'-4" (711)	APW6824	APW7024	APW7424	APW7824	APW8024
2'-7 1/4" (794)	2'-8" (813)	APW6828	APW7028	APW7428	APW7828	APW8028
2'-11 1/4" (895)	3'-0" (914)	APW6830	APW7030	APW7430	APW7830	APW8030
3'-3 1/4" (997)	3'-4" (1016)	APW6834	APW7034	APW7434	APW7834	APW8034
3'-7 1/4" (1099)	3'-8" (1118)	APW6838	APW7038	APW7438	APW7838	APW8038
3'-11 1/4" (1200)	4'-0" (1219)	APW6840	APW7040	APW7440	APW7840	APW8040
4'-3 1/4" (1302)	4'-4" (1321)	APW6844	APW7044	APW7444	APW7844	APW8044
4'-7 1/4" (1403)	4'-8" (1422)	APW6848	APW7048	APW7448	APW7848	APW8048
4'-11 1/4" (1505)	5'-0" (1524)	APW6850	APW7050	APW7450	APW7850	APW8050*
5'-3 1/4" (1607)	5'-4" (1626)	APW6854	APW7054	APW7454	APW7854*	APW8054*
5'-7 1/4" (1708)	5'-8" (1727)	APW6858	APW7058	APW7458*	APW7858*	APW8058*
5'-11 1/4" (1810)	6'-0" (1829)	APW6860	APW7060*	APW7460*	APW7860*	APW8060*



Custom-size windows are available in 1/8" (3) increments. See page 62 for custom sizes and specifications.

**Picture window must be installed as shown and should not be rotated.** Tall bottom rail is designed to align with bottom rail of double-hung and casement windows.

Details shown on page 49. Grille patterns shown on page 45.

\* "Window Dimension" always refers to outside frame to frame dimension.  
 • "Minimum Rough Opening" dimensions may need to be increased to allow for use of building wraps, flashing, sill panning, brackets, fasteners or other items. See installation information on page 170.  
 • Dimensions in parentheses are in millimeters.  
 \*Tempered laminated glass required. Some visual distortion may occur.



**Picture Window Area Specifications**

Window Number	Glass Area Sq. Ft./ (m <sup>2</sup> )	Overall Window Area Sq. Ft./ (m <sup>2</sup> )
APW1420	0.94 (0.09)	2.46 (0.23)
APW1424	1.18 (0.11)	2.89 (0.27)
APW1428	1.42 (0.13)	3.31 (0.31)
APW1430	1.66 (0.15)	3.73 (0.35)
APW1434	1.90 (0.18)	4.16 (0.39)
APW1438	2.14 (0.20)	4.58 (0.43)
APW1440	2.38 (0.22)	5.00 (0.46)
APW1444	2.62 (0.24)	5.43 (0.50)
APW1448	2.85 (0.26)	5.85 (0.54)
APW1450	3.09 (0.29)	6.27 (0.58)
APW1454	3.33 (0.31)	6.70 (0.62)
APW1458	3.57 (0.33)	7.12 (0.66)
APW1460	3.81 (0.35)	7.55 (0.70)
APW1464	4.05 (0.38)	7.97 (0.74)
APW1468	4.29 (0.40)	8.39 (0.78)
APW1474	4.77 (0.44)	9.24 (0.86)
APW1480	5.24 (0.49)	10.09 (0.94)
APW1820	1.38 (0.13)	3.11 (0.29)
APW1824	1.73 (0.16)	3.64 (0.34)
APW1828	2.08 (0.19)	4.18 (0.39)
APW1830	2.43 (0.23)	4.71 (0.44)
APW1834	2.78 (0.26)	5.25 (0.49)
APW1838	3.13 (0.29)	5.78 (0.54)
APW1840	3.48 (0.32)	6.32 (0.59)
APW1844	3.83 (0.36)	6.85 (0.64)
APW1848	4.18 (0.39)	7.39 (0.69)
APW1850	4.53 (0.42)	7.92 (0.74)
APW1854	4.88 (0.45)	8.46 (0.79)
APW1858	5.23 (0.49)	8.99 (0.84)
APW1860	5.58 (0.52)	9.52 (0.88)
APW1864	5.93 (0.55)	10.06 (0.93)
APW1868	6.28 (0.58)	10.59 (0.98)
APW1874	6.98 (0.65)	11.66 (1.08)
APW1880	7.68 (0.71)	12.73 (1.18)
APW2020	1.82 (0.17)	3.75 (0.35)
APW2024	2.28 (0.21)	4.40 (0.41)
APW2028	2.74 (0.25)	5.05 (0.47)
APW2030	3.20 (0.30)	5.69 (0.53)
APW2034	3.67 (0.34)	6.34 (0.59)
APW2038	4.13 (0.38)	6.98 (0.65)
APW2040	4.59 (0.43)	7.63 (0.71)
APW2044	5.05 (0.47)	8.27 (0.77)
APW2048	5.51 (0.51)	8.92 (0.83)
APW2050	5.97 (0.55)	9.57 (0.89)
APW2054	6.43 (0.60)	10.21 (0.95)
APW2058	6.89 (0.64)	10.86 (1.01)
APW2060	7.35 (0.68)	11.50 (1.07)
APW2064	7.82 (0.73)	12.15 (1.13)
APW2068	8.28 (0.77)	12.80 (1.19)
APW2074	9.20 (0.85)	14.09 (1.31)
APW2080	10.12 (0.94)	15.38 (1.43)
APW2420	2.26 (0.21)	4.40 (0.41)
APW2424	2.83 (0.26)	5.16 (0.48)
APW2428	3.40 (0.32)	5.91 (0.55)
APW2430	3.98 (0.37)	6.67 (0.62)
APW2434	4.55 (0.42)	7.43 (0.69)
APW2438	5.12 (0.48)	8.18 (0.76)
APW2440	5.69 (0.53)	8.94 (0.83)
APW2444	6.27 (0.58)	9.70 (0.90)
APW2448	6.84 (0.64)	10.46 (0.97)
APW2450	7.41 (0.69)	11.21 (1.04)

Window Number	Glass Area Sq. Ft./ (m <sup>2</sup> )	Overall Window Area Sq. Ft./ (m <sup>2</sup> )
APW2454	7.98 (0.74)	11.97 (1.11)
APW2458	8.55 (0.79)	12.73 (1.18)
APW2460	9.13 (0.85)	13.48 (1.25)
APW2464	9.70 (0.90)	14.24 (1.32)
APW2468	10.27 (0.95)	15.00 (1.39)
APW2474	11.42 (1.06)	16.51 (1.53)
APW2480	12.56 (1.17)	18.02 (1.67)
APW2620	2.48 (0.23)	4.72 (0.44)
APW2624	3.11 (0.29)	5.54 (0.51)
APW2628	3.74 (0.35)	6.35 (0.59)
APW2630	4.36 (0.41)	7.16 (0.67)
APW2634	4.99 (0.46)	7.97 (0.74)
APW2638	5.62 (0.52)	8.79 (0.82)
APW2640	6.25 (0.58)	9.60 (0.89)
APW2644	6.87 (0.64)	10.41 (0.97)
APW2648	7.50 (0.70)	11.22 (1.04)
APW2650	8.13 (0.76)	12.04 (1.12)
APW2654	8.76 (0.81)	12.85 (1.19)
APW2658	9.39 (0.87)	13.66 (1.27)
APW2660	10.01 (0.93)	14.47 (1.34)
APW2664	10.64 (0.99)	15.29 (1.42)
APW2668	11.27 (1.05)	16.10 (1.50)
APW2674	12.52 (1.16)	17.72 (1.65)
APW2680	13.78 (1.28)	19.35 (1.80)
APW2820	2.70 (0.25)	5.05 (0.47)
APW2824	3.38 (0.31)	5.91 (0.55)
APW2828	4.07 (0.38)	6.78 (0.63)
APW2830	4.75 (0.44)	7.65 (0.71)
APW2834	5.43 (0.50)	8.52 (0.79)
APW2838	6.12 (0.57)	9.39 (0.87)
APW2840	6.80 (0.63)	10.25 (0.95)
APW2844	7.48 (0.69)	11.12 (1.03)
APW2848	8.17 (0.76)	11.99 (1.11)
APW2850	8.85 (0.82)	12.86 (1.19)
APW2854	9.53 (0.89)	13.73 (1.28)
APW2858	10.22 (0.95)	14.59 (1.36)
APW2860	10.90 (1.01)	15.46 (1.44)
APW2864	11.58 (1.08)	16.33 (1.52)
APW2868	12.27 (1.14)	17.20 (1.60)
APW2874	13.63 (1.27)	18.93 (1.76)
APW2880	15.00 (1.39)	20.67 (1.92)
APW21020	2.92 (0.27)	5.37 (0.50)
APW21024	3.66 (0.34)	6.29 (0.58)
APW21024	3.66 (0.34)	6.29 (0.58)
APW21028	4.40 (0.41)	7.22 (0.67)
APW21030	5.14 (0.48)	8.14 (0.76)
APW21034	5.87 (0.55)	9.06 (0.84)
APW21038	6.61 (0.61)	9.99 (0.93)
APW21040	7.35 (0.68)	10.91 (1.01)
APW21044	8.09 (0.75)	11.83 (1.10)
APW21048	8.83 (0.82)	12.76 (1.19)
APW21050	9.57 (0.89)	13.68 (1.27)
APW21054	10.31 (0.96)	14.60 (1.36)
APW21058	11.05 (1.03)	15.53 (1.44)
APW21060	11.79 (1.10)	16.45 (1.53)
APW21064	12.52 (1.16)	17.38 (1.61)
APW21068	13.26 (1.23)	18.30 (1.70)
APW21074	14.74 (1.37)	20.15 (1.87)
APW21080	16.22 (1.51)	21.99 (2.04)
APW3020	3.14 (0.29)	5.69 (0.53)
APW3024	3.93 (0.37)	6.67 (0.62)

Window Number	Glass Area Sq. Ft./ (m <sup>2</sup> )	Overall Window Area Sq. Ft./ (m <sup>2</sup> )
APW3028	4.73 (0.44)	7.65 (0.71)
APW3030	5.52 (0.51)	8.63 (0.80)
APW3034	6.32 (0.59)	9.61 (0.89)
APW3038	7.11 (0.66)	10.59 (0.98)
APW3040	7.90 (0.73)	11.57 (1.07)
APW3044	8.70 (0.81)	12.55 (1.17)
APW3044	8.70 (0.81)	12.55 (1.17)
APW3048	9.49 (0.88)	13.52 (1.26)
APW3050	10.29 (0.96)	14.50 (1.35)
APW3054	11.08 (1.03)	15.48 (1.44)
APW3058	11.88 (1.10)	16.46 (1.53)
APW3060	12.67 (1.18)	17.44 (1.62)
APW3064	13.47 (1.25)	18.42 (1.71)
APW3068	14.26 (1.32)	19.40 (1.80)
APW3074	15.85 (1.47)	21.36 (1.98)
APW3080	17.44 (1.62)	23.32 (2.17)
APW3220	3.36 (0.31)	6.01 (0.56)
APW3224	4.21 (0.39)	7.05 (0.65)
APW3228	5.06 (0.47)	8.08 (0.75)
APW3230	5.91 (0.55)	9.12 (0.85)
APW3234	6.76 (0.63)	10.15 (0.94)
APW3238	7.61 (0.71)	11.19 (1.04)
APW3240	8.46 (0.79)	12.22 (1.14)
APW3244	9.31 (0.86)	13.26 (1.23)
APW3248	10.16 (0.94)	14.29 (1.33)
APW3250	11.01 (1.02)	15.33 (1.42)
APW3254	11.86 (1.10)	16.36 (1.52)
APW3258	12.71 (1.18)	17.40 (1.62)
APW3260	13.56 (1.26)	18.43 (1.71)
APW3264	14.41 (1.34)	19.47 (1.81)
APW3268	15.26 (1.42)	20.50 (1.90)
APW3274	16.96 (1.58)	22.57 (2.10)
APW3280	18.66 (1.73)	24.64 (2.29)
APW3420	3.58 (0.33)	6.34 (0.59)
APW3424	4.48 (0.42)	7.43 (0.69)
APW3428	5.39 (0.50)	8.52 (0.79)
APW3430	6.29 (0.58)	9.61 (0.89)
APW3434	7.20 (0.67)	10.70 (0.99)
APW3438	8.10 (0.75)	11.79 (1.10)
APW3440	9.01 (0.84)	12.88 (1.20)
APW3444	9.92 (0.92)	13.97 (1.30)
APW3448	10.82 (1.01)	15.06 (1.40)
APW3450	11.73 (1.09)	16.15 (1.50)
APW3454	12.63 (1.17)	17.24 (1.60)
APW3458	13.54 (1.26)	18.33 (1.70)
APW3460	14.44 (1.34)	19.42 (1.80)
APW3464	15.35 (1.43)	20.51 (1.91)
APW3468	16.25 (1.51)	21.60 (2.01)
APW3474	18.07 (1.68)	23.78 (2.21)
APW3480	19.88 (1.85)	25.96 (2.41)
APW3820	4.02 (0.37)	6.98 (0.65)
APW3824	5.03 (0.47)	8.18 (0.76)
APW3828	6.05 (0.56)	9.39 (0.87)
APW3830	7.07 (0.66)	10.59 (0.98)
APW3834	8.08 (0.75)	11.79 (1.10)
APW3838	9.10 (0.85)	12.99 (1.21)
APW3840	10.12 (0.94)	14.19 (1.32)
APW3844	11.13 (1.03)	15.39 (1.43)
APW3848	12.15 (1.13)	16.59 (1.54)
APW3850	13.17 (1.22)	17.80 (1.65)

\*Dimensions in parentheses are in square meters.

continued on next page

A-Series Picture Windows

Picture Window Area Specifications *(continued)*

Window Number	Glass Area		Overall Window Area	
	Sq. Ft./	(m <sup>2</sup> )	Sq. Ft./	(m <sup>2</sup> )
APW3854	14.18	(1.32)	19.00	(1.77)
APW3858	15.20	(1.41)	20.20	(1.88)
APW3860	16.22	(1.51)	21.40	(1.99)
APW3864	17.23	(1.60)	22.60	(2.10)
APW3868	18.25	(1.70)	23.80	(2.21)
APW3874	20.28	(1.88)	26.21	(2.43)
APW3880	22.32	(2.07)	28.61	(2.66)
APW4020	4.45	(0.41)	7.63	(0.71)
APW4024	5.58	(0.52)	8.94	(0.83)
APW4028	6.71	(0.62)	10.25	(0.95)
APW4030	7.84	(0.73)	11.57	(1.07)
APW4034	8.97	(0.83)	12.88	(1.20)
APW4038	10.09	(0.94)	14.19	(1.32)
APW4040	11.22	(1.04)	15.50	(1.44)
APW4044	12.35	(1.15)	16.82	(1.56)
APW4048	13.48	(1.25)	18.13	(1.68)
APW4050	14.60	(1.36)	19.44	(1.81)
APW4054	15.73	(1.46)	20.75	(1.93)
APW4058	16.86	(1.57)	22.07	(2.05)
APW4060	17.99	(1.67)	23.38	(2.17)
APW4064	19.12	(1.78)	24.69	(2.29)
APW4068	20.24	(1.88)	26.00	(2.42)
APW4074	22.50	(2.09)	28.63	(2.66)
APW4080	24.75	(2.30)	31.25	(2.90)
APW4420	4.89	(0.45)	8.27	(0.77)
APW4424	6.13	(0.57)	9.70	(0.90)
APW4428	7.37	(0.68)	11.12	(1.03)
APW4430	8.61	(0.80)	12.55	(1.17)
APW4434	9.85	(0.92)	13.97	(1.30)
APW4438	11.09	(1.03)	15.39	(1.43)
APW4440	12.33	(1.15)	16.82	(1.56)
APW4444	13.57	(1.26)	18.24	(1.69)
APW4448	14.80	(1.37)	19.66	(1.83)
APW4450	16.04	(1.49)	21.09	(1.96)
APW4454	17.28	(1.61)	22.51	(2.09)
APW4458	18.52	(1.72)	23.93	(2.22)
APW4460	19.76	(1.84)	25.36	(2.36)
APW4464	21.00	(1.95)	26.78	(2.49)
APW4468	22.24	(2.07)	28.21	(2.62)
APW4474	24.72	(2.30)	31.05	(2.88)
APW4480	27.19	(2.53)	33.90	(3.15)
APW4820	5.33	(0.50)	8.92	(0.83)
APW4824	6.68	(0.62)	10.46	(0.97)
APW4828	8.03	(0.75)	11.99	(1.11)
APW4830	9.38	(0.87)	13.52	(1.26)
APW4834	10.73	(1.00)	15.06	(1.40)
APW4838	12.08	(1.12)	16.59	(1.54)
APW4840	13.43	(1.25)	18.13	(1.68)
APW4844	14.78	(1.37)	19.66	(1.83)
APW4848	16.13	(1.50)	21.20	(1.97)
APW4850	17.48	(1.62)	22.73	(2.11)
APW4854	18.83	(1.75)	24.27	(2.25)
APW4858	20.18	(1.87)	25.80	(2.40)
APW4860	21.53	(2.00)	27.34	(2.54)
APW4864	22.88	(2.13)	28.87	(2.68)
APW4868	24.23	(2.25)	30.41	(2.83)
APW4874	26.93	(2.50)	33.48	(3.11)
APW4880	29.63	(2.75)	36.55	(3.40)
APW5020	5.77	(0.54)	9.57	(0.89)
APW5024	7.23	(0.67)	11.21	(1.04)
APW5028	8.69	(0.81)	12.86	(1.19)

Window Number	Glass Area		Overall Window Area	
	Sq. Ft./	(m <sup>2</sup> )	Sq. Ft./	(m <sup>2</sup> )
APW5030	10.15	(0.94)	14.50	(1.35)
APW5034	11.62	(1.08)	16.15	(1.50)
APW5038	13.08	(1.22)	17.80	(1.65)
APW5040	14.54	(1.35)	19.44	(1.81)
APW5044	16.00	(1.49)	21.09	(1.96)
APW5048	17.46	(1.62)	22.73	(2.11)
APW5050	18.92	(1.76)	24.38	(2.26)
APW5054	20.38	(1.89)	26.02	(2.42)
APW5058	21.84	(2.03)	27.67	(2.57)
APW5060	23.30	(2.16)	29.32	(2.72)
APW5064	24.77	(2.30)	30.96	(2.88)
APW5068	26.23	(2.44)	32.61	(3.03)
APW5074	29.15	(2.71)	35.90	(3.34)
APW5080	32.07	(2.98)	39.19	(3.64)
APW5420	6.21	(0.58)	10.21	(0.95)
APW5424	7.78	(0.72)	11.97	(1.11)
APW5428	9.35	(0.87)	13.73	(1.28)
APW5430	10.93	(1.02)	15.48	(1.44)
APW5434	12.50	(1.16)	17.24	(1.60)
APW5438	14.07	(1.31)	19.00	(1.77)
APW5440	15.64	(1.45)	20.75	(1.93)
APW5444	17.22	(1.60)	22.51	(2.09)
APW5448	18.79	(1.75)	24.27	(2.25)
APW5450	20.36	(1.89)	26.02	(2.42)
APW5454	21.93	(2.04)	27.78	(2.58)
APW5458	23.50	(2.18)	29.54	(2.74)
APW5460	25.08	(2.33)	31.30	(2.91)
APW5464	26.65	(2.48)	33.05	(3.07)
APW5468	28.22	(2.62)	34.81	(3.23)
APW5474	31.37	(2.91)	38.32	(3.56)
APW5480	34.51	(3.21)	41.84	(3.89)
APW5820	6.65	(0.62)	10.86	(1.01)
APW5824	8.33	(0.77)	12.73	(1.18)
APW5828	10.02	(0.93)	14.59	(1.36)
APW5830	11.70	(1.09)	16.46	(1.53)
APW5834	13.38	(1.24)	18.33	(1.70)
APW5838	15.07	(1.40)	20.20	(1.88)
APW5840	16.75	(1.56)	22.07	(2.05)
APW5844	18.43	(1.71)	23.93	(2.22)
APW5848	20.12	(1.87)	25.80	(2.40)
APW5850	21.80	(2.03)	27.67	(2.57)
APW5854	23.48	(2.18)	29.54	(2.74)
APW5858	25.17	(2.34)	31.41	(2.92)
APW5860	26.85	(2.49)	33.27	(3.09)
APW5864	28.53	(2.65)	35.14	(3.26)
APW5868	30.22	(2.81)	37.01	(3.44)
APW5874	33.58	(3.12)	40.75	(3.79)
APW5880	36.95	(3.43)	44.48	(4.13)
APW6020	7.09	(0.66)	11.50	(1.07)
APW6024	8.88	(0.82)	13.48	(1.25)
APW6028	10.68	(0.99)	15.46	(1.44)
APW6030	12.47	(1.16)	17.44	(1.62)
APW6034	14.27	(1.33)	19.42	(1.80)
APW6038	16.06	(1.49)	21.40	(1.99)
APW6040	17.85	(1.66)	23.38	(2.17)
APW6044	19.65	(1.83)	25.36	(2.36)
APW6048	21.44	(1.99)	27.34	(2.54)
APW6050	23.24	(2.16)	29.32	(2.72)
APW6054	25.03	(2.33)	31.30	(2.91)
APW6058	26.83	(2.49)	33.27	(3.09)
APW6060	28.62	(2.66)	35.25	(3.27)

Window Number	Glass Area		Overall Window Area	
	Sq. Ft./	(m <sup>2</sup> )	Sq. Ft./	(m <sup>2</sup> )
APW6064	30.42	(2.83)	37.23	(3.46)
APW6068	32.21	(2.99)	39.21	(3.64)
APW6074	35.80	(3.33)	43.17	(4.01)
APW6080	39.39	(3.66)	47.13	(4.38)
APW6420	7.53	(0.70)	12.15	(1.13)
APW6424	9.43	(0.88)	14.24	(1.32)
APW6428	11.34	(1.05)	16.33	(1.52)
APW6430	13.24	(1.23)	18.42	(1.71)
APW6434	15.15	(1.41)	20.51	(1.91)
APW6438	17.05	(1.58)	22.60	(2.10)
APW6440	18.96	(1.76)	24.69	(2.29)
APW6444	20.87	(1.94)	26.78	(2.49)
APW6448	22.77	(2.12)	28.87	(2.68)
APW6450	24.68	(2.29)	30.96	(2.88)
APW6454	26.58	(2.47)	33.05	(3.07)
APW6458	28.49	(2.65)	35.14	(3.26)
APW6460	30.39	(2.82)	37.23	(3.46)
APW6820	7.97	(0.74)	12.80	(1.19)
APW6824	9.98	(0.98)	15.00	(1.39)
APW6828	12.00	(1.11)	17.20	(1.60)
APW6830	14.02	(1.30)	19.40	(1.80)
APW6834	16.03	(1.49)	21.60	(2.01)
APW6838	18.05	(1.68)	23.80	(2.21)
APW6840	20.07	(1.86)	26.00	(2.42)
APW6844	22.08	(2.05)	28.20	(2.62)
APW6848	24.10	(2.24)	30.40	(2.82)
APW6850	26.12	(2.43)	32.61	(3.03)
APW6854	28.13	(2.61)	34.81	(3.23)
APW6858	30.15	(2.80)	37.01	(3.44)
APW6860	32.17	(2.99)	39.21	(3.64)
APW7020	8.40	(0.78)	13.44	(1.25)
APW7024	10.53	(0.98)	15.75	(1.46)
APW7028	12.66	(1.18)	18.07	(1.68)
APW7030	14.79	(1.37)	20.38	(1.89)
APW7034	16.92	(1.57)	22.69	(2.11)
APW7038	19.04	(1.77)	25.00	(2.32)
APW7040	21.17	(1.97)	27.32	(2.54)
APW7044	23.30	(2.16)	29.63	(2.75)
APW7048	25.43	(2.36)	31.94	(2.97)
APW7050	27.55	(2.56)	34.25	(3.18)
APW7054	29.68	(2.76)	36.57	(3.40)
APW7058	31.81	(2.96)	38.88	(3.61)
APW7060	33.94	(3.15)	41.19	(3.83)
APW7420	8.84	(0.82)	14.09	(1.31)
APW7424	11.08	(1.03)	16.51	(1.53)
APW7428	13.32	(1.24)	18.93	(1.76)
APW7430	15.56	(1.45)	21.36	(1.98)
APW7434	17.80	(1.65)	23.78	(2.21)
APW7438	20.04	(1.86)	26.21	(2.43)
APW7440	22.28	(2.07)	28.63	(2.66)
APW7444	24.52	(2.28)	31.05	(2.88)
APW7448	26.75	(2.49)	33.48	(3.11)
APW7450	29.00	(2.69)	35.90	(3.34)
APW7454	31.23	(2.90)	38.32	(3.56)
APW7458	33.47	(3.11)	40.75	(3.79)
APW7460	35.71	(3.32)	43.17	(4.01)
APW7820	9.28	(0.86)	14.73	(1.37)
APW7824	11.63	(1.08)	17.26	(1.60)
APW7828	13.98	(1.30)	19.80	(1.84)
APW7830	16.33	(1.52)	22.34	(2.08)

\* Dimensions in parentheses are in square meters.

*continued on next page*

**Picture Window Area Specifications** *(continued)*

Window Number	Glass Area Sq. Ft./ (m <sup>2</sup> )	Overall Window Area Sq. Ft./ (m <sup>2</sup> )
APW7834	18.68 (1.74)	24.87 (2.31)
APW7838	21.03 (1.95)	27.41 (2.55)
APW7840	23.38 (2.17)	29.94 (2.78)
APW7844	25.73 (2.39)	32.48 (3.02)
APW7848	28.08 (2.61)	35.01 (3.25)
APW7850	30.43 (2.83)	37.55 (3.49)
APW7854	32.78 (3.05)	40.08 (3.72)
APW7858	35.13 (3.26)	42.62 (3.96)
APW7860	37.48 (3.48)	45.15 (4.19)
APW8020	9.72 (0.90)	15.38 (1.43)
APW8024	12.18 (1.13)	18.02 (1.67)
APW8028	14.64 (1.36)	20.67 (1.92)
APW8030	17.10 (1.59)	23.32 (2.17)
APW8034	19.57 (1.82)	25.96 (2.41)
APW8038	22.03 (2.05)	28.61 (2.66)
APW8040	24.49 (2.28)	31.25 (2.90)
APW8044	26.95 (2.50)	33.90 (3.15)
APW8048	29.41 (2.73)	36.55 (3.40)
APW8050	31.87 (2.96)	39.19 (3.64)
APW8054	34.33 (3.19)	41.84 (3.89)
APW8058	36.79 (3.42)	44.48 (4.13)
APW8060	39.25 (3.65)	47.13 (4.38)

\* Dimensions in parentheses are in square meters.

**Picture Window Details**

Scale 1 1/2" (38) = 1'-0" (305) – 1:8

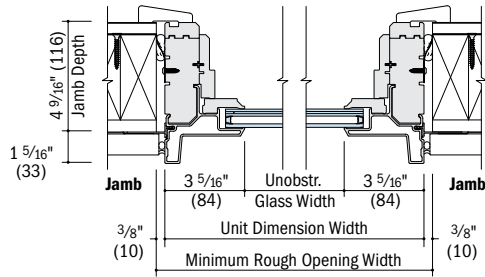

**Horizontal Section**  
Low-E4\* Impact-Resistant Glass

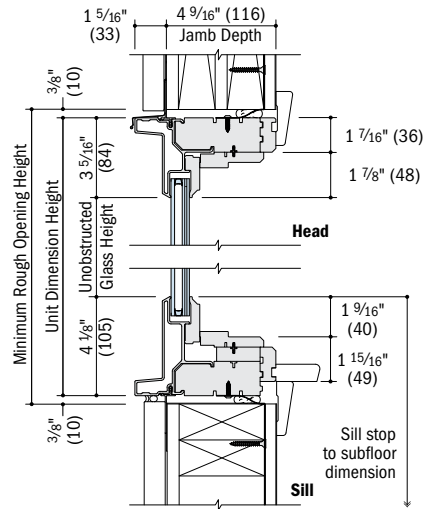

**Vertical Section**  
Low-E4\* Impact-Resistant Glass

A-Series Picture Windows

See pages 57-59 for horizontal and vertical joining details.

- 4 9/16" (116) jamb depth measurement is from back side of installation flange.
- Light-colored areas are parts included with window. Dark-colored areas are additional Andersen® parts required to complete window assembly as shown.
- Dimensions in parentheses are in millimeters.
- Minimum rough opening dimensions may need to be increased to allow for use of building wraps, flashing, sill panning, brackets, fasteners or other items. See installation information on page 170.
- Details are for illustration only and are not intended to represent product installation methods or materials. Refer to product installation guides at andersenwindows.com.

## Table of Transom Window Sizes

Scale 1/8" (3) = 1'-0" (305) – 1:96

Notes on the next page also apply to this page.

Window Dimension	1'-3 1/4" (387)	1'-7 1/4" (489)	1'-11 1/4" (591)	2'-3 1/4" (692)	2'-5 1/4" (743)	2'-7 1/4" (794)	2'-9 1/4" (845)	2'-11 1/4" (895)	3'-1 1/4" (946)	3'-3 1/4" (997)	3'-7 1/4" (1099)	3'-11 1/4" (1200)
<b>Minimum Rough Opening</b>	1'-4" (406)	1'-8" (508)	2'-0" (610)	2'-4" (711)	2'-6" (762)	2'-8" (813)	2'-10" (864)	3'-0" (914)	3'-2" (965)	3'-4" (1016)	3'-8" (1118)	4'-0" (1219)
<b>Unobstructed Glass</b>	8 5/8" (219)	12 5/8" (321)	16 5/8" (422)	20 5/8" (524)	22 5/8" (575)	24 5/8" (625)	26 5/8" (676)	28 5/8" (727)	30 5/8" (778)	32 5/8" (829)	36 5/8" (930)	40 5/8" (1032)

Window Dimension	CUSTOM SIZES AVAILABLE											
	ATF1410	ATF1810	ATF2010	ATF2410	ATF2610	ATF2810	ATF21010	ATF3010	ATF3210	ATF3410	ATF3810	ATF4010
11 1/4" (286)												
1'-3 1/4" (387)	ATF1414	ATF1814	ATF2014	ATF2414	ATF2614	ATF2814	ATF21014	ATF3014	ATF3214	ATF3414	ATF3814	ATF4014
	ATV1814	ATV2014	ATV2414	ATV2614	ATV2814	ATV21014	ATV3014	ATV3214	ATV3414	ATV3814	ATV4014	
1'-5 1/4" (438)	ATF1416	ATF1816	ATF2016	ATF2416	ATF2616	ATF2816	ATF21016	ATF3016	ATF3216	ATF3416	ATF3816	ATF4016
	ATV1816	ATV2016	ATV2416	ATV2616	ATV2816	ATV21016	ATV3016	ATV3216	ATV3416	ATV3816	ATV4016	
1'-7 1/4" (489)	ATF1418	ATF1818	ATF2018	ATF2418	ATF2618	ATF2818	ATF21018	ATF3018	ATF3218	ATF3418	ATF3818	ATF4018
	ATV1818	ATV2018	ATV2418	ATV2618	ATV2818	ATV21018	ATV3018	ATV3218	ATV3418	ATV3818	ATV4018	
1'-9 1/4" (540)	ATF14110	ATF18110	ATF20110	ATF24110	ATF26110	ATF28110	ATF210110	ATF30110	ATF32110	ATF34110	ATF38110	ATF40110
	ATV18110	ATV20110	ATV24110	ATV26110	ATV28110	ATV210110	ATV30110	ATV32110	ATV34110	ATV38110	ATV40110	
1'-11 1/4" (591)	ATF1420	ATF1820	ATF2020	ATF2420	ATF2620	ATF2820	ATF21020	ATF3020	ATF3220	ATF3420	ATF3820	ATF4020
	ATV1820	ATV2020	ATV2420	ATV2620	ATV2820	ATV21020	ATV3020	ATV3220	ATV3420	ATV3820	ATV4020	
2'-1 1/4" (641)	ATF1422	ATF1822	ATF2022	ATF2422	ATF2622	ATF2822	ATF21022	ATF3022	ATF3222	ATF3422	ATF3822	ATF4022
	ATV1822	ATV2022	ATV2422	ATV2622	ATV2822	ATV21022	ATV3022	ATV3222	ATV3422	ATV3822	ATV4022	
2'-3 1/4" (692)	ATF1424	ATF1824	ATF2024	ATF2424	ATF2624	ATF2824	ATF21024	ATF3024	ATF3224	ATF3424	ATF3824	ATF4024
	ATV1824	ATV2024	ATV2424	ATV2624	ATV2824	ATV21024	ATV3024	ATV3224	ATV3424	ATV3824	ATV4024	
2'-5 1/4" (743)	ATF1426	ATF1826	ATF2026	ATF2426	ATF2626	ATF2826	ATF21026	ATF3026	ATF3226	ATF3426	ATF3826	ATF4026
	ATV1826	ATV2026	ATV2426	ATV2626	ATV2826	ATV21026	ATV3026	ATV3226	ATV3426	ATV3826	ATV4026	
2'-7 1/4" (794)	ATF1428	ATF1828	ATF2028	ATF2428	ATF2628	ATF2828	ATF21028	ATF3028	ATF3228	ATF3428	ATF3828	ATF4028
	ATV1828	ATV2028	ATV2428	ATV2628	ATV2828	ATV21028	ATV3028	ATV3228	ATV3428	ATV3828	ATV4028	

Picture sizes on pages 50-53.

4'-3 1/4" (1302)	4'-7 1/4" (1403)	4'-11 1/4" (1505)	5'-3 1/4" (1607)	5'-7 1/4" (1708)	5'-11 1/4" (1810)
4'-4" (1321)	4'-8" (1422)	5'-0" (1524)	5'-4" (1626)	5'-8" (1727)	6'-0" (1829)
44 5/8" (1133)	48 5/8" (1335)	52 5/8" (1337)	56 5/8" (1438)	60 5/8" (1540)	64 5/8" (1641)



Custom-size windows are available in 1/8" (3) increments. See page 62 for custom sizes and specifications.

ATF4410	ATF4810	ATF5010	ATF5410	ATF5810	ATF6010
ATF4414	ATF4814	ATF5014	ATF5414	ATF5814	ATF6014
ATV4414	ATV4814	ATV5014			
ATF4416	ATF4816	ATF5016	ATF5416	ATF5816	ATF6016
ATV4416	ATV4816	ATV5016			
ATF4418	ATF4818	ATF5018	ATF5418	ATF5818	ATF6018
ATV4418	ATV4818	ATV5018			
ATF44110	ATF48110	ATF50110	ATF54110	ATF58110	ATF60110
ATV44110	ATV48110	ATV50110			
ATF4420	ATF4820	ATF5020	ATF5420	ATF5820	ATF6020
ATV4420	ATV4820	ATV5020			
ATF4422	ATF4822	ATF5022	ATF5422	ATF5822	ATF6022
ATV4422	ATV4822	ATV5022			
ATF4424	ATF4824	ATF5024	ATF5424	ATF5824	ATF6024
ATV4424	ATV4824	ATV5024			
ATF4426	ATF4826	ATF5026	ATF5426	ATF5826	ATF6026
ATV4426	ATV4826	ATV5026			
ATF4428	ATF4828	ATF5028	ATF5428	ATF5828	ATF6028
ATV4428	ATV4828	ATV5028			

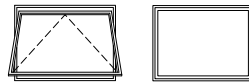

Venting Transom Fixed Transom

Choose venting (ATV) or fixed (ATF).

**Venting window must be installed to vent as shown and should not be rotated and used as a hopper.**

Details shown on page 56.

Grille patterns shown on page 55.

- "Window Dimension" always refers to outside frame to frame dimension.
- "Minimum Rough Opening" dimensions may need to be increased to allow for use of building wraps, flashing, sill panning, brackets, fasteners or other items. See installation information on page 170.
- Dimensions in parentheses are in millimeters.

continued on next page

**Table of Transom Window Sizes** (continued)

Scale 1/8" (3) = 1'-0" (305) – 1:96

Notes on the next page also apply to this page.

Window Dimension	1'-3 1/4" (387)	1'-7 1/4" (489)	1'-11 1/4" (591)	2'-3 1/4" (692)	2'-5 1/4" (743)	2'-7 1/4" (794)	2'-9 1/4" (845)	2'-11 1/4" (895)	3'-1 1/4" (946)	3'-3 1/4" (997)	3'-7 1/4" (1099)	3'-11 1/4" (1200)
<b>Minimum Rough Opening</b>	1'-4" (406)	1'-8" (508)	2'-0" (610)	2'-4" (711)	2'-6" (762)	2'-8" (813)	2'-10" (864)	3'-0" (914)	3'-2" (965)	3'-4" (1016)	3'-8" (1118)	4'-0" (1219)
Unobstructed Glass	8 5/8" (219)	12 5/8" (321)	16 5/8" (422)	20 5/8" (524)	22 5/8" (575)	24 5/8" (625)	26 5/8" (676)	28 5/8" (727)	30 5/8" (778)	32 5/8" (829)	36 5/8" (930)	40 5/8" (1032)

**CUSTOM SIZES AVAILABLE**

Window Dimension	2'-11 1/4" (895)	3'-0" (914)	28 5/8" (727)
<b>CUSTOM AVAILABLE</b>	ATF1430	ATF1830	ATF2030
	ATF1434	ATF1834	ATF2034
	ATF2430	ATF2630	ATF2830
	ATF2434	ATF2634	ATF2834
	ATF21030	ATF21034	ATF3030
	ATF3030	ATF3230	ATF3430
	ATF3230	ATF3430	ATF3830
	ATF3430	ATF3830	ATF4030
	ATF3434	ATF3834	ATF4034
	ATF3834	ATF4034	

- \* "Window Dimension" always refers to outside frame to frame dimension.
- \*\* "Minimum Rough Opening" dimensions may need to be increased to allow for use of building wraps, flashing, sill panning, brackets, fasteners or other items. See installation information on page 170.
- \* Dimensions in parentheses are in millimeters.

## Venting Transom Window Opening and Area Specifications

Window Number	Clear Opening Sq. Ft./ (m <sup>2</sup> )	Clear Opening in Full Open Position		Glass Area Sq. Ft./ (m <sup>2</sup> )	Vent Sq. Ft./ (m <sup>2</sup> )	Top of Subfloor to Top of Inside Sill Stop Inches/ (mm)	Overall Window Area Sq. Ft./ (m <sup>2</sup> )
		Width Inches/ (mm)	Depth Inches/ (mm)				
ATV1814	0.59 (0.05)	14 5/16" (364)	5 7/8" (149)	0.75 (0.07)	0.59 (0.05)	69 1/2" (1765)	2.04 (0.19)
ATV1816	0.59 (0.05)	14 5/16" (364)	5 7/8" (149)	0.93 (0.09)	0.59 (0.05)	67 1/2" (1715)	2.31 (0.21)
ATV1818	0.59 (0.05)	14 5/16" (364)	5 7/8" (149)	1.10 (0.10)	0.59 (0.05)	65 1/2" (1664)	2.57 (0.24)
ATV18110	0.59 (0.05)	14 5/16" (364)	5 7/8" (149)	1.28 (0.12)	0.59 (0.05)	63 1/2" (1613)	2.84 (0.26)
ATV1820	0.59 (0.05)	14 5/16" (364)	5 7/8" (149)	1.45 (0.13)	0.59 (0.05)	61 1/2" (1562)	3.11 (0.29)
ATV1822	0.59 (0.05)	14 5/16" (364)	5 7/8" (149)	1.63 (0.15)	0.59 (0.05)	59 1/2" (1511)	3.38 (0.31)
ATV1824	0.59 (0.05)	14 5/16" (364)	5 7/8" (149)	1.80 (0.17)	0.59 (0.05)	57 1/2" (1461)	3.64 (0.34)
ATV1826	0.59 (0.05)	14 5/16" (364)	5 7/8" (149)	1.98 (0.18)	0.59 (0.05)	55 1/2" (1410)	3.91 (0.36)
ATV1828	0.59 (0.05)	14 5/16" (364)	5 7/8" (149)	2.15 (0.20)	0.59 (0.05)	53 1/2" (1359)	4.18 (0.39)
ATV2014	0.75 (0.07)	18 5/16" (465)	5 7/8" (149)	0.99 (0.09)	0.75 (0.07)	69 1/2" (1765)	2.46 (0.23)
ATV2016	0.75 (0.07)	18 5/16" (465)	5 7/8" (149)	1.22 (0.11)	0.75 (0.07)	67 1/2" (1715)	2.79 (0.26)
ATV2018	0.75 (0.07)	18 5/16" (465)	5 7/8" (149)	1.45 (0.13)	0.75 (0.07)	65 1/2" (1664)	3.11 (0.29)
ATV20110	0.75 (0.07)	18 5/16" (465)	5 7/8" (149)	1.68 (0.16)	0.75 (0.07)	63 1/2" (1613)	3.43 (0.32)
ATV2020	0.75 (0.07)	18 5/16" (465)	5 7/8" (149)	1.91 (0.18)	0.75 (0.07)	61 1/2" (1562)	3.75 (0.35)
ATV2022	0.75 (0.07)	18 5/16" (465)	5 7/8" (149)	2.14 (0.20)	0.75 (0.07)	59 1/2" (1511)	4.08 (0.38)
ATV2024	0.75 (0.07)	18 5/16" (465)	5 7/8" (149)	2.38 (0.22)	0.75 (0.07)	57 1/2" (1461)	4.40 (0.41)
ATV2026	0.75 (0.07)	18 5/16" (465)	5 7/8" (149)	2.61 (0.24)	0.75 (0.07)	55 1/2" (1410)	4.72 (0.44)
ATV2028	0.75 (0.07)	18 5/16" (465)	5 7/8" (149)	2.84 (0.26)	0.75 (0.07)	53 1/2" (1359)	5.05 (0.47)
ATV2414	0.91 (0.08)	22 5/16" (567)	5 7/8" (149)	1.23 (0.11)	0.91 (0.08)	69 1/2" (1765)	2.89 (0.27)
ATV2416	0.91 (0.08)	22 5/16" (567)	5 7/8" (149)	1.52 (0.14)	0.91 (0.08)	67 1/2" (1715)	3.26 (0.30)
ATV2418	0.91 (0.08)	22 5/16" (567)	5 7/8" (149)	1.80 (0.17)	0.91 (0.08)	65 1/2" (1664)	3.64 (0.34)
ATV24110	0.91 (0.08)	22 5/16" (567)	5 7/8" (149)	2.09 (0.19)	0.91 (0.08)	63 1/2" (1613)	4.02 (0.37)
ATV2420	0.91 (0.08)	22 5/16" (567)	5 7/8" (149)	2.38 (0.22)	0.91 (0.08)	61 1/2" (1562)	4.40 (0.41)
ATV2422	0.91 (0.08)	22 5/16" (567)	5 7/8" (149)	2.66 (0.25)	0.91 (0.08)	59 1/2" (1511)	4.78 (0.44)
ATV2424	0.91 (0.08)	22 5/16" (567)	5 7/8" (149)	2.95 (0.27)	0.91 (0.08)	57 1/2" (1461)	5.16 (0.48)
ATV2426	0.91 (0.08)	22 5/16" (567)	5 7/8" (149)	3.23 (0.30)	0.91 (0.08)	55 1/2" (1410)	5.54 (0.51)
ATV2428	0.91 (0.08)	22 5/16" (567)	5 7/8" (149)	3.52 (0.33)	0.91 (0.08)	53 1/2" (1359)	5.91 (0.55)
ATV2614	0.99 (0.09)	24 5/16" (618)	5 7/8" (149)	1.35 (0.13)	0.99 (0.09)	69 1/2" (1765)	3.10 (0.29)
ATV2616	0.99 (0.09)	24 5/16" (618)	5 7/8" (149)	1.66 (0.15)	0.99 (0.09)	67 1/2" (1715)	3.50 (0.33)
ATV2618	0.99 (0.09)	24 5/16" (618)	5 7/8" (149)	1.98 (0.18)	0.99 (0.09)	65 1/2" (1664)	3.91 (0.36)
ATV26110	0.99 (0.09)	24 5/16" (618)	5 7/8" (149)	2.29 (0.21)	0.99 (0.09)	63 1/2" (1613)	4.32 (0.40)
ATV2620	0.99 (0.09)	24 5/16" (618)	5 7/8" (149)	2.61 (0.24)	0.99 (0.09)	61 1/2" (1562)	4.72 (0.44)
ATV2622	0.99 (0.09)	24 5/16" (618)	5 7/8" (149)	2.92 (0.27)	0.99 (0.09)	59 1/2" (1511)	5.13 (0.48)
ATV2624	0.99 (0.09)	24 5/16" (618)	5 7/8" (149)	3.23 (0.30)	0.99 (0.09)	57 1/2" (1461)	5.54 (0.51)
ATV2626	0.99 (0.09)	24 5/16" (618)	5 7/8" (149)	3.55 (0.33)	0.99 (0.09)	55 1/2" (1410)	5.94 (0.55)
ATV2628	0.99 (0.09)	24 5/16" (618)	5 7/8" (149)	3.86 (0.36)	0.99 (0.09)	53 1/2" (1359)	6.35 (0.59)

- \* "Top of Subfloor to Top of Inside Sill Stop" is calculated based upon a structural header height of 6'-10 1/2" (2096).
- \* Dimensions in parentheses are in millimeters or square meters.

continued on next page

continued on next page

## Fixed Transom Window Area Specifications

Window Number	Glass Area Sq. Ft./ (m <sup>2</sup> )	Overall Window Area Sq. Ft./ (m <sup>2</sup> )
ATF1410	0.27 (0.03)	1.19 (0.11)
ATF1414	0.51 (0.05)	1.62 (0.15)
ATF1416	0.63 (0.06)	1.83 (0.17)
ATF1418	0.75 (0.07)	2.04 (0.19)
ATF14110	0.87 (0.08)	2.25 (0.21)
ATF1420	0.99 (0.09)	2.46 (0.23)
ATF1422	1.11 (0.10)	2.67 (0.25)
ATF1424	1.23 (0.11)	2.89 (0.27)
ATF1426	1.35 (0.13)	3.10 (0.29)
ATF1428	1.47 (0.14)	3.31 (0.31)
ATF1430	1.71 (0.16)	3.73 (0.35)
ATF1434	1.95 (0.18)	4.16 (0.39)
ATF1810	0.40 (0.04)	1.50 (0.14)
ATF1814	0.75 (0.07)	2.04 (0.19)
ATF1816	0.93 (0.09)	2.31 (0.21)
ATF1818	1.10 (0.10)	2.57 (0.24)
ATF18110	1.28 (0.12)	2.84 (0.26)
ATF1820	1.45 (0.13)	3.11 (0.29)
ATF1822	1.63 (0.15)	3.38 (0.31)
ATF1824	1.80 (0.17)	3.64 (0.34)
ATF1826	1.98 (0.18)	3.91 (0.36)
ATF1828	2.15 (0.20)	4.18 (0.39)
ATF1830	2.50 (0.23)	4.71 (0.44)
ATF1834	2.85 (0.26)	5.25 (0.49)
ATF2010	0.53 (0.05)	1.82 (0.17)
ATF2014	0.99 (0.09)	2.46 (0.23)
ATF2016	1.22 (0.11)	2.79 (0.26)
ATF2018	1.45 (0.13)	3.11 (0.29)
ATF20110	1.68 (0.16)	3.43 (0.32)
ATF2020	1.91 (0.18)	3.75 (0.35)
ATF2022	2.14 (0.20)	4.08 (0.38)
ATF2024	2.37 (0.22)	4.40 (0.41)
ATF2026	2.61 (0.24)	4.72 (0.44)
ATF2028	2.84 (0.26)	5.05 (0.47)
ATF2030	3.30 (0.31)	5.69 (0.53)

- \* Dimensions in parentheses are in square meters.

Picture sizes on pages 50-53.

4'-3 1/4" (1302)	4'-7 1/4" (1403)	4'-11 1/4" (1505)	5'-3 1/4" (1607)	5'-7 1/4" (1708)	5'-11 1/4" (1810)
4'-4" (1321)	4'-8" (1422)	5'-0" (1524)	5'-4" (1626)	5'-8" (1727)	6'-0" (1829)
44 5/8" (1133)	48 5/8" (1335)	52 5/8" (1337)	56 5/8" (1438)	60 5/8" (1540)	64 5/8" (1641)



Custom-size windows are available in 1/8" (3) increments.  
See page 62 for custom sizes and specifications.

Choose venting (ATV) or fixed (ATF). See pages 50-51  
for venting sizes. Details shown on page 56.  
Grille patterns shown on page 55.

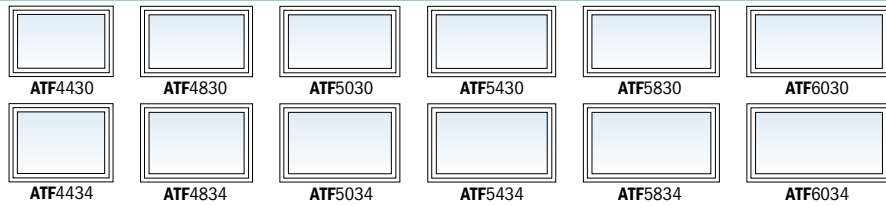

- "Window Dimension" always refers to outside frame to frame dimension.
- "Minimum Rough Opening" dimensions may need to be increased to allow for use of building wraps, flashing, sill panning, brackets, fasteners or other items. See installation information on page 170.
- Dimensions in parentheses are in millimeters.

**Venting Transom Window Opening and Area Specifications** (continued)

Window Number	Clear Opening		Clear Opening in Full Open Position		Glass Area Sq. Ft./ (m <sup>2</sup> )	Vent Sq. Ft./ (m <sup>2</sup> )	Top of Subfloor to Top of Inside Sill Stop Inches/(mm)	Overall Window Area Sq. Ft./ (m <sup>2</sup> )
	Sq. Ft./ (m <sup>2</sup> )	Width Inches/(mm)	Depth Inches/(mm)	Width Inches/(mm)				
ATV2814	1.08 (0.10)	26 5/16" (668)	5 7/8" (149)	1.47 (0.14)	1.08 (0.10)	69 1/2" (1765)	3.31 (0.31)	
ATV2816	1.08 (0.10)	26 5/16" (668)	5 7/8" (149)	1.81 (0.17)	1.08 (0.10)	67 1/2" (1715)	3.74 (0.35)	
ATV2818	1.08 (0.10)	26 5/16" (668)	5 7/8" (149)	2.15 (0.20)	1.08 (0.10)	65 1/2" (1664)	4.18 (0.39)	
ATV28110	1.08 (0.10)	26 5/16" (668)	5 7/8" (149)	2.49 (0.23)	1.08 (0.10)	63 1/2" (1613)	4.61 (0.43)	
ATV2820	1.08 (0.10)	26 5/16" (668)	5 7/8" (149)	2.84 (0.26)	1.08 (0.10)	61 1/2" (1562)	5.05 (0.47)	
ATV2822	1.08 (0.10)	26 5/16" (668)	5 7/8" (149)	3.18 (0.30)	1.08 (0.10)	59 1/2" (1511)	5.48 (0.51)	
ATV2824	1.08 (0.10)	26 5/16" (668)	5 7/8" (149)	3.52 (0.33)	1.08 (0.10)	57 1/2" (1461)	5.91 (0.55)	
ATV2826	1.08 (0.10)	26 5/16" (668)	5 7/8" (149)	3.86 (0.36)	1.08 (0.10)	55 1/2" (1410)	6.35 (0.59)	
ATV2828	1.08 (0.10)	26 5/16" (668)	5 7/8" (149)	4.20 (0.39)	1.08 (0.10)	53 1/2" (1359)	6.78 (0.63)	
ATV21014	1.16 (0.11)	28 5/16" (719)	5 7/8" (149)	1.59 (0.15)	1.16 (0.11)	69 1/2" (1765)	3.52 (0.33)	
ATV21016	1.16 (0.11)	28 5/16" (719)	5 7/8" (149)	1.96 (0.18)	1.16 (0.11)	67 1/2" (1715)	3.98 (0.37)	
ATV21018	1.16 (0.11)	28 5/16" (719)	5 7/8" (149)	2.33 (0.22)	1.16 (0.11)	65 1/2" (1664)	4.45 (0.41)	
ATV210110	1.16 (0.11)	28 5/16" (719)	5 7/8" (149)	2.70 (0.25)	1.16 (0.11)	63 1/2" (1613)	4.91 (0.46)	
ATV21020	1.16 (0.11)	28 5/16" (719)	5 7/8" (149)	3.07 (0.29)	1.16 (0.11)	61 1/2" (1562)	5.37 (0.50)	
ATV21022	1.16 (0.11)	28 5/16" (719)	5 7/8" (149)	3.44 (0.32)	1.16 (0.11)	59 1/2" (1511)	5.83 (0.54)	
ATV21024	1.16 (0.11)	28 5/16" (719)	5 7/8" (149)	3.81 (0.35)	1.16 (0.11)	57 1/2" (1461)	6.29 (0.58)	
ATV21026	1.16 (0.11)	28 5/16" (719)	5 7/8" (149)	4.18 (0.39)	1.16 (0.11)	55 1/2" (1410)	6.75 (0.63)	
ATV21028	1.16 (0.11)	28 5/16" (719)	5 7/8" (149)	4.54 (0.42)	1.16 (0.11)	53 1/2" (1359)	7.22 (0.67)	
ATV3014	1.24 (0.12)	30 5/16" (770)	5 7/8" (149)	1.71 (0.16)	1.24 (0.12)	69 1/2" (1765)	3.73 (0.35)	
ATV3016	1.24 (0.12)	30 5/16" (770)	5 7/8" (149)	2.11 (0.20)	1.24 (0.12)	67 1/2" (1715)	4.22 (0.39)	
ATV3018	1.24 (0.12)	30 5/16" (770)	5 7/8" (149)	2.50 (0.23)	1.24 (0.12)	65 1/2" (1664)	4.71 (0.44)	
ATV30110	1.24 (0.12)	30 5/16" (770)	5 7/8" (149)	2.90 (0.27)	1.24 (0.12)	63 1/2" (1613)	5.20 (0.48)	
ATV3020	1.24 (0.12)	30 5/16" (770)	5 7/8" (149)	3.30 (0.31)	1.24 (0.12)	61 1/2" (1562)	5.69 (0.53)	
ATV3022	1.24 (0.12)	30 5/16" (770)	5 7/8" (149)	3.69 (0.34)	1.24 (0.12)	59 1/2" (1511)	6.18 (0.57)	
ATV3024	1.24 (0.12)	30 5/16" (770)	5 7/8" (149)	4.09 (0.38)	1.24 (0.12)	57 1/2" (1461)	6.67 (0.62)	
ATV3026	1.24 (0.12)	30 5/16" (770)	5 7/8" (149)	4.49 (0.42)	1.24 (0.12)	55 1/2" (1410)	7.16 (0.67)	
ATV3028	1.24 (0.12)	30 5/16" (770)	5 7/8" (149)	4.89 (0.45)	1.24 (0.12)	53 1/2" (1359)	7.66 (0.70)	
ATV3214	1.32 (0.12)	32 5/16" (821)	5 7/8" (149)	1.83 (0.17)	1.32 (0.12)	69 1/2" (1765)	3.95 (0.37)	
ATV3216	1.32 (0.12)	32 5/16" (821)	5 7/8" (149)	2.25 (0.21)	1.32 (0.12)	67 1/2" (1715)	4.46 (0.41)	
ATV3218	1.32 (0.12)	32 5/16" (821)	5 7/8" (149)	2.68 (0.25)	1.32 (0.12)	65 1/2" (1664)	4.98 (0.46)	
ATV32110	1.32 (0.12)	32 5/16" (821)	5 7/8" (149)	3.10 (0.29)	1.32 (0.12)	63 1/2" (1613)	5.50 (0.51)	
ATV3220	1.32 (0.12)	32 5/16" (821)	5 7/8" (149)	3.53 (0.33)	1.32 (0.12)	61 1/2" (1562)	6.01 (0.56)	
ATV3222	1.32 (0.12)	32 5/16" (821)	5 7/8" (149)	3.95 (0.37)	1.32 (0.12)	59 1/2" (1511)	6.53 (0.61)	
ATV3224	1.32 (0.12)	32 5/16" (821)	5 7/8" (149)	4.38 (0.41)	1.32 (0.12)	57 1/2" (1461)	7.05 (0.65)	
ATV3226	1.32 (0.12)	32 5/16" (821)	5 7/8" (149)	4.80 (0.45)	1.32 (0.12)	55 1/2" (1410)	7.57 (0.70)	
ATV3228	1.32 (0.12)	32 5/16" (821)	5 7/8" (149)	5.23 (0.49)	1.32 (0.12)	53 1/2" (1359)	8.08 (0.75)	

• "Top of Subfloor to Top of Inside Sill Stop" is calculated based upon a structural header height of 6'-10 1/2" (2096).  
• Dimensions in parentheses are in millimeters or square meters.

continued on next page

continued on next page

**Fixed Transom Window Area Specifications** (continued)

Window Number	Glass Area Sq. Ft./ (m <sup>2</sup> )	Overall Window Area Sq. Ft./ (m <sup>2</sup> )
ATF2034	3.76 (0.35)	6.34 (0.59)
ATF2410	0.66 (0.06)	2.13 (0.20)
ATF2414	1.23 (0.11)	2.89 (0.27)
ATF2416	1.52 (0.14)	3.26 (0.30)
ATF2418	1.80 (0.17)	3.64 (0.34)
ATF24110	2.09 (0.19)	4.02 (0.37)
ATF2420	2.37 (0.22)	4.40 (0.41)
ATF2422	2.66 (0.25)	4.78 (0.44)
ATF2424	2.95 (0.27)	5.16 (0.48)
ATF2426	3.23 (0.30)	5.54 (0.51)
ATF2428	3.52 (0.33)	5.91 (0.55)
ATF2430	4.09 (0.38)	6.67 (0.62)
ATF2434	4.66 (0.43)	7.43 (0.69)
ATF2610	0.72 (0.07)	2.29 (0.21)
ATF2614	1.35 (0.13)	3.10 (0.29)
ATF2616	1.66 (0.15)	3.50 (0.33)
ATF2618	1.98 (0.18)	3.91 (0.36)
ATF26110	2.29 (0.21)	4.32 (0.40)
ATF2620	2.61 (0.24)	4.72 (0.44)
ATF2622	2.92 (0.27)	5.13 (0.48)
ATF2624	3.23 (0.30)	5.54 (0.51)
ATF2626	3.55 (0.33)	5.94 (0.55)
ATF2628	3.86 (0.36)	6.35 (0.59)
ATF2630	4.49 (0.42)	7.16 (0.67)
ATF2634	5.12 (0.48)	7.97 (0.74)
ATF2810	0.79 (0.07)	2.44 (0.23)
ATF2814	1.47 (0.14)	3.31 (0.31)
ATF2816	1.81 (0.17)	3.74 (0.35)
ATF2818	2.15 (0.20)	4.18 (0.39)
ATF28110	2.49 (0.23)	4.61 (0.43)
ATF2820	2.84 (0.26)	5.05 (0.47)
ATF2822	3.18 (0.30)	5.48 (0.51)
ATF2824	3.52 (0.33)	5.91 (0.55)
ATF2826	3.86 (0.36)	6.35 (0.59)
ATF2828	4.20 (0.39)	6.78 (0.63)

• Dimensions in parentheses are in square meters.

**Venting Transom Window Opening and Area Specifications** *(continued)*

Window Number	Clear Opening Sq. Ft./ (m <sup>2</sup> )		Clear Opening in Full Open Position				Glass Area Sq. Ft./ (m <sup>2</sup> )	Vent Sq. Ft./ (m <sup>2</sup> )		Top of Subfloor to Top of Inside Sill Stop Inches/ (mm)	Overall Window Area Sq. Ft./ (m <sup>2</sup> )			
			Width Inches/ (mm)		Depth Inches/ (mm)									
ATV3414	1.40	(0.13)	34 5/16"	(872)	5 7/8"	(149)	1.95	(0.18)	1.40	(0.13)	69 1/2"	(1765)	4.16	(0.39)
ATV3416	1.40	(0.13)	34 5/16"	(872)	5 7/8"	(149)	2.40	(0.22)	1.40	(0.13)	67 1/2"	(1715)	4.70	(0.44)
ATV3418	1.40	(0.13)	34 5/16"	(872)	5 7/8"	(149)	2.85	(0.26)	1.40	(0.13)	65 1/2"	(1664)	5.25	(0.49)
ATV34110	1.40	(0.13)	34 5/16"	(872)	5 7/8"	(149)	3.31	(0.31)	1.40	(0.13)	63 1/2"	(1613)	5.79	(0.54)
ATV3420	1.40	(0.13)	34 5/16"	(872)	5 7/8"	(149)	3.76	(0.35)	1.40	(0.13)	61 1/2"	(1562)	6.34	(0.59)
ATV3422	1.40	(0.13)	34 5/16"	(872)	5 7/8"	(149)	4.21	(0.39)	1.40	(0.13)	59 1/2"	(1511)	6.88	(0.64)
ATV3424	1.40	(0.13)	34 5/16"	(872)	5 7/8"	(149)	4.66	(0.43)	1.40	(0.13)	57 1/2"	(1461)	7.43	(0.69)
ATV3426	1.40	(0.13)	34 5/16"	(872)	5 7/8"	(149)	5.12	(0.48)	1.40	(0.13)	55 1/2"	(1410)	7.97	(0.74)
ATV3428	1.40	(0.13)	34 5/16"	(872)	5 7/8"	(149)	5.57	(0.52)	1.40	(0.13)	53 1/2"	(1359)	8.52	(0.79)
ATV3814	1.57	(0.15)	38 5/16"	(973)	5 7/8"	(149)	2.19	(0.20)	1.57	(0.15)	69 1/2"	(1765)	4.58	(0.43)
ATV3816	1.57	(0.15)	38 5/16"	(973)	5 7/8"	(149)	2.69	(0.25)	1.57	(0.15)	67 1/2"	(1715)	5.18	(0.48)
ATV3818	1.57	(0.15)	38 5/16"	(973)	5 7/8"	(149)	3.20	(0.30)	1.57	(0.15)	65 1/2"	(1664)	5.78	(0.54)
ATV38110	1.57	(0.15)	38 5/16"	(973)	5 7/8"	(149)	3.71	(0.34)	1.57	(0.15)	63 1/2"	(1613)	6.38	(0.59)
ATV3820	1.57	(0.15)	38 5/16"	(973)	5 7/8"	(149)	4.22	(0.39)	1.57	(0.15)	61 1/2"	(1562)	6.98	(0.65)
ATV3822	1.57	(0.15)	38 5/16"	(973)	5 7/8"	(149)	4.73	(0.44)	1.57	(0.15)	59 1/2"	(1511)	7.58	(0.70)
ATV3824	1.57	(0.15)	38 5/16"	(973)	5 7/8"	(149)	5.24	(0.49)	1.57	(0.15)	57 1/2"	(1461)	8.18	(0.76)
ATV3826	1.57	(0.15)	38 5/16"	(973)	5 7/8"	(149)	5.74	(0.53)	1.57	(0.15)	55 1/2"	(1410)	8.79	(0.82)
ATV3828	1.57	(0.15)	38 5/16"	(973)	5 7/8"	(149)	6.25	(0.58)	1.57	(0.15)	53 1/2"	(1359)	9.39	(0.87)
ATV4014	1.73	(0.16)	42 5/16"	(1075)	5 7/8"	(149)	2.43	(0.23)	1.73	(0.16)	69 1/2"	(1765)	5.00	(0.46)
ATV4016	1.73	(0.16)	42 5/16"	(1075)	5 7/8"	(149)	2.99	(0.28)	1.73	(0.16)	67 1/2"	(1715)	5.66	(0.53)
ATV4018	1.73	(0.16)	42 5/16"	(1075)	5 7/8"	(149)	3.55	(0.33)	1.73	(0.16)	65 1/2"	(1664)	6.32	(0.59)
ATV40110	1.73	(0.16)	42 5/16"	(1075)	5 7/8"	(149)	4.12	(0.38)	1.73	(0.16)	63 1/2"	(1613)	6.97	(0.65)
ATV4020	1.73	(0.16)	42 5/16"	(1075)	5 7/8"	(149)	4.68	(0.43)	1.73	(0.16)	61 1/2"	(1562)	7.63	(0.71)
ATV4022	1.73	(0.16)	42 5/16"	(1075)	5 7/8"	(149)	5.24	(0.49)	1.73	(0.16)	59 1/2"	(1511)	8.29	(0.77)
ATV4024	1.73	(0.16)	42 5/16"	(1075)	5 7/8"	(149)	5.81	(0.54)	1.73	(0.16)	57 1/2"	(1461)	8.94	(0.83)
ATV4026	1.73	(0.16)	42 5/16"	(1075)	5 7/8"	(149)	6.37	(0.59)	1.73	(0.16)	55 1/2"	(1410)	9.60	(0.89)
ATV4028	1.73	(0.16)	42 5/16"	(1075)	5 7/8"	(149)	6.94	(0.64)	1.73	(0.16)	53 1/2"	(1359)	10.25	(0.95)
ATV4414	1.90	(0.18)	46 5/16"	(1176)	5 7/8"	(149)	2.66	(0.25)	1.90	(0.18)	69 1/2"	(1765)	5.43	(0.50)
ATV4416	1.90	(0.18)	46 5/16"	(1176)	5 7/8"	(149)	3.28	(0.30)	1.90	(0.18)	67 1/2"	(1715)	6.14	(0.57)
ATV4418	1.90	(0.18)	46 5/16"	(1176)	5 7/8"	(149)	3.90	(0.36)	1.90	(0.18)	65 1/2"	(1664)	6.85	(0.64)
ATV44110	1.90	(0.18)	46 5/16"	(1176)	5 7/8"	(149)	4.55	(0.42)	1.90	(0.18)	63 1/2"	(1613)	7.56	(0.70)
ATV4420	1.90	(0.18)	46 5/16"	(1176)	5 7/8"	(149)	5.14	(0.48)	1.90	(0.18)	61 1/2"	(1562)	8.28	(0.77)
ATV4422	1.90	(0.18)	46 5/16"	(1176)	5 7/8"	(149)	5.76	(0.54)	1.90	(0.18)	59 1/2"	(1511)	8.99	(0.84)
ATV4424	1.90	(0.18)	46 5/16"	(1176)	5 7/8"	(149)	6.38	(0.59)	1.90	(0.18)	57 1/2"	(1461)	9.70	(0.90)
ATV4426	1.90	(0.18)	46 5/16"	(1176)	5 7/8"	(149)	7.00	(0.65)	1.90	(0.18)	55 1/2"	(1410)	10.41	(0.97)
ATV4428	1.90	(0.18)	46 5/16"	(1176)	5 7/8"	(149)	7.62	(0.71)	1.90	(0.18)	53 1/2"	(1359)	11.12	(1.03)
ATV4814	2.06	(0.19)	50 5/16"	(1278)	5 7/8"	(149)	2.90	(0.27)	2.06	(0.19)	69 1/2"	(1765)	5.85	(0.54)
ATV4816	2.06	(0.19)	50 5/16"	(1278)	5 7/8"	(149)	3.58	(0.33)	2.06	(0.19)	67 1/2"	(1715)	6.62	(0.62)
ATV4818	2.06	(0.19)	50 5/16"	(1278)	5 7/8"	(149)	4.25	(0.39)	2.06	(0.19)	65 1/2"	(1664)	7.39	(0.69)
ATV48110	2.06	(0.19)	50 5/16"	(1278)	5 7/8"	(149)	4.93	(0.46)	2.06	(0.19)	63 1/2"	(1613)	8.15	(0.76)
ATV4820	2.06	(0.19)	50 5/16"	(1278)	5 7/8"	(149)	5.60	(0.52)	2.06	(0.19)	61 1/2"	(1562)	8.92	(0.83)
ATV4822	2.06	(0.19)	50 5/16"	(1278)	5 7/8"	(149)	6.28	(0.58)	2.06	(0.19)	59 1/2"	(1511)	9.69	(0.90)
ATV4824	2.06	(0.19)	50 5/16"	(1278)	5 7/8"	(149)	6.95	(0.65)	2.06	(0.19)	57 1/2"	(1461)	10.46	(0.97)
ATV4826	2.06	(0.19)	50 5/16"	(1278)	5 7/8"	(149)	7.63	(0.71)	2.06	(0.19)	55 1/2"	(1410)	11.22	(1.04)
ATV4828	2.06	(0.19)	50 5/16"	(1278)	5 7/8"	(149)	8.30	(0.77)	2.06	(0.19)	53 1/2"	(1359)	11.99	(1.11)
ATV5014	2.22	(0.21)	54 5/16"	(1380)	5 7/8"	(149)	3.14	(0.29)	2.22	(0.21)	69 1/2"	(1765)	6.28	(0.58)
ATV5016	2.22	(0.21)	54 5/16"	(1380)	5 7/8"	(149)	3.87	(0.36)	2.22	(0.21)	67 1/2"	(1715)	7.10	(0.66)
ATV5018	2.22	(0.21)	54 5/16"	(1380)	5 7/8"	(149)	4.60	(0.43)	2.22	(0.21)	65 1/2"	(1664)	7.92	(0.74)
ATV50110	2.22	(0.21)	54 5/16"	(1380)	5 7/8"	(149)	5.33	(0.50)	2.22	(0.21)	63 1/2"	(1613)	8.74	(0.81)
ATV5020	2.22	(0.21)	54 5/16"	(1380)	5 7/8"	(149)	6.06	(0.56)	2.22	(0.21)	61 1/2"	(1562)	9.57	(0.89)
ATV5022	2.22	(0.21)	54 5/16"	(1380)	5 7/8"	(149)	6.79	(0.63)	2.22	(0.21)	59 1/2"	(1511)	10.39	(0.97)
ATV5024	2.22	(0.21)	54 5/16"	(1380)	5 7/8"	(149)	7.53	(0.70)	2.22	(0.21)	57 1/2"	(1461)	11.21	(1.04)
ATV5026	2.22	(0.21)	54 5/16"	(1380)	5 7/8"	(149)	8.26	(0.77)	2.22	(0.21)	55 1/2"	(1410)	12.04	(1.12)
ATV5028	2.22	(0.21)	54 5/16"	(1380)	5 7/8"	(149)	8.99	(0.84)	2.22	(0.21)	53 1/2"	(1359)	12.86	(1.19)

\*"Top of Subfloor to Top of Inside Sill Stop" is calculated based upon a structural header height of 6'-10 1/2" (2096).  
 \*Dimensions in parentheses are in millimeters or square meters.

**Fixed Transom Window Area Specifications** *(continued)*

Window Number	Glass Area Sq. Ft./ (m <sup>2</sup> )	Overall Window Area Sq. Ft./ (m <sup>2</sup> )
ATF2830	4.89 (0.45)	7.65 (0.71)
ATF2834	5.57 (0.52)	8.52 (0.79)
ATF21010	0.85 (0.08)	2.60 (0.24)
ATF21014	1.59 (0.15)	3.52 (0.33)
ATF21016	1.96 (0.18)	3.98 (0.37)
ATF21018	2.33 (0.22)	4.44 (0.41)
ATF210110	2.70 (0.25)	4.91 (0.46)
ATF21020	3.07 (0.29)	5.37 (0.50)
ATF21022	3.44 (0.32)	5.83 (0.54)
ATF21024	3.81 (0.35)	6.29 (0.58)
ATF21026	4.17 (0.39)	6.75 (0.63)
ATF21028	4.54 (0.42)	7.22 (0.67)
ATF21030	5.28 (0.49)	8.14 (0.76)
ATF21034	6.02 (0.56)	9.06 (0.84)
ATF3010	0.91 (0.08)	2.75 (0.26)
ATF3014	1.71 (0.16)	3.73 (0.35)
ATF3016	2.11 (0.20)	4.22 (0.39)
ATF3018	2.50 (0.23)	4.71 (0.44)
ATF30110	2.90 (0.27)	5.20 (0.48)
ATF3020	3.30 (0.31)	5.69 (0.53)
ATF3022	3.69 (0.34)	6.18 (0.57)
ATF3024	4.09 (0.38)	6.67 (0.62)
ATF3026	4.49 (0.42)	7.16 (0.67)
ATF3028	4.89 (0.45)	7.65 (0.71)
ATF3030	5.68 (0.53)	8.63 (0.80)
ATF3034	6.47 (0.60)	9.61 (0.89)
ATF3210	0.98 (0.09)	2.91 (0.27)
ATF3214	1.83 (0.17)	3.94 (0.37)
ATF3216	2.25 (0.21)	4.46 (0.41)
ATF3218	2.68 (0.25)	4.98 (0.46)
ATF32110	3.10 (0.29)	5.50 (0.51)
ATF3220	3.53 (0.33)	6.01 (0.56)
ATF3222	3.95 (0.37)	6.53 (0.61)
ATF3224	4.38 (0.41)	7.05 (0.65)
ATF3226	4.80 (0.45)	7.57 (0.70)
ATF3228	5.23 (0.49)	8.08 (0.75)
ATF3230	6.08 (0.56)	9.12 (0.85)
ATF3234	6.93 (0.64)	10.15 (0.94)
ATF3410	1.04 (0.10)	3.07 (0.29)
ATF3414	1.95 (0.18)	4.16 (0.39)
ATF3416	2.40 (0.22)	4.70 (0.44)
ATF3418	2.85 (0.26)	5.25 (0.49)
ATF34110	3.31 (0.31)	5.79 (0.54)
ATF3420	3.76 (0.35)	6.34 (0.59)
ATF3422	4.21 (0.39)	6.88 (0.64)
ATF3424	4.66 (0.43)	7.43 (0.69)
ATF3426	5.12 (0.48)	7.97 (0.74)
ATF3428	5.57 (0.52)	8.52 (0.79)
ATF3430	6.47 (0.60)	9.61 (0.89)
ATF3434	7.38 (0.69)	10.70 (0.99)
ATF3810	1.17 (0.11)	3.38 (0.31)
ATF3814	2.19 (0.20)	4.58 (0.43)
ATF3816	2.69 (0.25)	5.18 (0.48)
ATF3818	3.20 (0.30)	5.78 (0.54)
ATF38110	3.71 (0.34)	6.38 (0.59)
ATF3820	4.22 (0.39)	6.98 (0.65)
ATF3822	4.73 (0.44)	7.58 (0.70)
ATF3824	5.24 (0.49)	8.18 (0.76)

\*Dimensions in parentheses are in square meters.

*continued on next page*



**Fixed Transom Window Area Specifications** *(continued)*

Window Number	Glass Area Sq. Ft./ (m <sup>2</sup> )	Overall Window Area Sq. Ft./ (m <sup>2</sup> )
ATF3826	5.74 (0.53)	8.79 (0.82)
ATF3828	6.25 (0.58)	9.39 (0.87)
ATF3830	7.27 (0.68)	10.59 (0.98)
ATF3834	8.29 (0.77)	11.79 (1.10)
ATF4010	1.30 (0.12)	3.69 (0.34)
ATF4014	2.42 (0.22)	5.00 (0.46)
ATF4016	2.99 (0.28)	5.66 (0.53)
ATF4018	3.55 (0.33)	6.32 (0.59)
ATF40110	4.12 (0.38)	6.97 (0.65)
ATF4020	4.68 (0.43)	7.63 (0.71)
ATF4022	5.24 (0.49)	8.29 (0.77)
ATF4024	5.81 (0.54)	8.94 (0.83)
ATF4026	6.37 (0.59)	9.60 (0.89)
ATF4028	6.94 (0.64)	10.25 (0.95)
ATF4030	8.06 (0.75)	11.57 (1.07)
ATF4034	9.19 (0.85)	12.88 (1.20)
ATF4410	1.42 (0.13)	4.00 (0.37)
ATF4414	2.66 (0.25)	5.43 (0.50)
ATF4416	3.28 (0.30)	6.14 (0.57)
ATF4418	3.90 (0.36)	6.85 (0.64)
ATF44110	4.52 (0.42)	7.56 (0.70)
ATF4420	5.14 (0.48)	8.27 (0.77)
ATF4422	5.76 (0.54)	8.99 (0.84)
ATF4424	6.38 (0.59)	9.70 (0.90)
ATF4426	7.00 (0.65)	10.41 (0.97)
ATF4428	7.62 (0.71)	11.12 (1.03)
ATF4430	8.86 (0.82)	12.55 (1.17)
ATF4434	10.10 (0.94)	13.97 (1.30)
ATF4810	1.55 (0.14)	4.32 (0.40)
ATF4814	2.90 (0.27)	5.85 (0.54)

Window Number	Glass Area Sq. Ft./ (m <sup>2</sup> )	Overall Window Area Sq. Ft./ (m <sup>2</sup> )
ATF4816	3.58 (0.33)	6.62 (0.62)
ATF4818	4.25 (0.39)	7.39 (0.69)
ATF48110	4.93 (0.46)	8.15 (0.76)
ATF4820	5.60 (0.52)	8.92 (0.83)
ATF4822	6.28 (0.58)	9.69 (0.90)
ATF4824	6.95 (0.65)	10.46 (0.97)
ATF4826	7.63 (0.71)	11.22 (1.04)
ATF4828	8.30 (0.77)	11.99 (1.11)
ATF4830	9.65 (0.90)	13.52 (1.26)
ATF4834	11.00 (1.02)	15.06 (1.40)
ATF5010	1.68 (0.16)	4.63 (0.43)
ATF5014	3.14 (0.29)	6.27 (0.58)
ATF5016	3.87 (0.36)	7.10 (0.66)
ATF5018	4.60 (0.43)	7.92 (0.74)
ATF50110	5.33 (0.50)	8.74 (0.81)
ATF5020	6.06 (0.56)	9.57 (0.89)
ATF5022	6.79 (0.63)	10.39 (0.97)
ATF5024	7.52 (0.70)	11.21 (1.04)
ATF5026	8.26 (0.77)	12.04 (1.12)
ATF5028	8.99 (0.84)	12.86 (1.19)
ATF5030	10.45 (0.97)	14.50 (1.35)
ATF5034	11.91 (1.11)	16.15 (1.50)
ATF5410	1.81 (0.17)	4.94 (0.46)
ATF5414	3.38 (0.31)	6.70 (0.62)
ATF5416	4.17 (0.39)	7.58 (0.70)
ATF5418	4.95 (0.46)	8.46 (0.79)
ATF54110	5.74 (0.53)	9.33 (0.87)
ATF5420	6.52 (0.61)	10.21 (0.95)
ATF5422	7.31 (0.68)	11.09 (1.03)
ATF5424	8.10 (0.75)	11.97 (1.11)

Window Number	Glass Area Sq. Ft./ (m <sup>2</sup> )	Overall Window Area Sq. Ft./ (m <sup>2</sup> )
ATF5426	8.88 (0.82)	12.85 (1.19)
ATF5428	9.67 (0.90)	13.73 (1.28)
ATF5430	11.24 (1.04)	15.48 (1.44)
ATF5434	12.81 (1.19)	17.24 (1.60)
ATF5810	1.94 (0.18)	5.25 (0.49)
ATF5814	3.62 (0.34)	7.12 (0.66)
ATF5816	4.46 (0.41)	8.06 (0.75)
ATF5818	5.30 (0.49)	8.99 (0.84)
ATF58110	6.14 (0.57)	9.92 (0.92)
ATF5820	6.99 (0.65)	10.86 (1.01)
ATF5822	7.83 (0.73)	11.79 (1.10)
ATF5824	8.67 (0.81)	12.73 (1.18)
ATF5826	9.51 (0.88)	13.66 (1.27)
ATF5828	10.35 (0.96)	14.59 (1.36)
ATF5830	12.04 (1.12)	16.46 (1.53)
ATF5834	13.72 (1.27)	18.33 (1.70)
ATF6010	2.06 (0.19)	5.57 (0.52)
ATF6014	3.86 (0.36)	7.55 (0.70)
ATF6016	4.76 (0.44)	8.54 (0.79)
ATF6018	5.65 (0.52)	9.52 (0.88)
ATF60110	6.55 (0.61)	10.51 (0.98)
ATF6020	7.45 (0.69)	11.50 (1.07)
ATF6022	8.34 (0.77)	12.49 (1.16)
ATF6024	9.24 (0.86)	13.48 (1.25)
ATF6026	10.14 (0.94)	14.47 (1.34)
ATF6028	11.04 (1.03)	15.46 (1.44)
ATF6030	12.83 (1.19)	17.44 (1.62)
ATF6034	14.62 (1.36)	19.42 (1.80)

\* Dimensions in parentheses are in square meters.

**Grille Patterns**

	Queen Anne	Diamond	Prairie A	Colonial
<b>Transom</b>				

\* Andersen® Finelight™ grilles available in 3/4" (19) profile only.

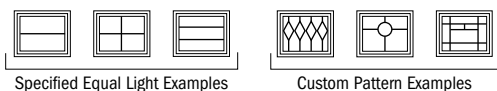

**Number of lights and overall pattern varies with window size.**

**Patterns shown may not be available for all sizes.** Specified equal light and custom patterns are also available. For more information on divided light, see page 15 or visit [andersenwindows.com/grilles](http://andersenwindows.com/grilles).

## Fixed Transom Window Details

Scale 1 1/2" (38) = 1'-0" (305) – 1:8

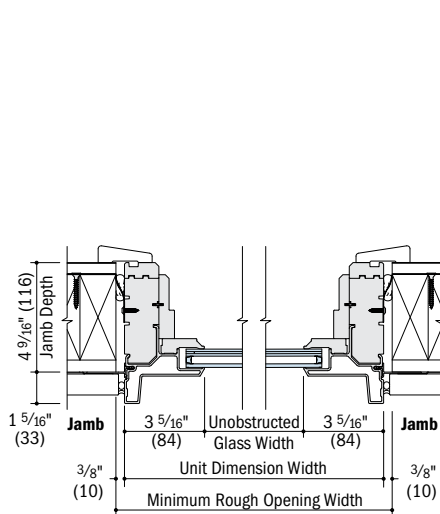

**Horizontal Section**  
Low-E4\* Impact-Resistant Glass

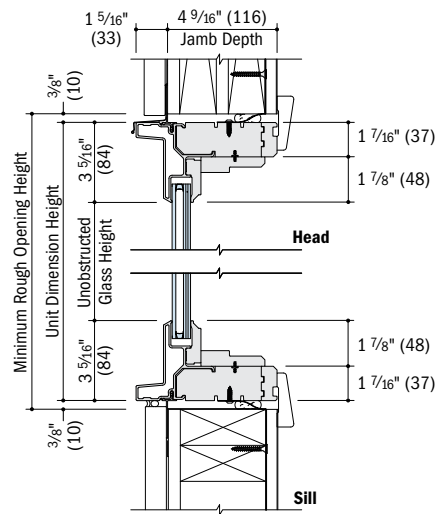

**Vertical Section**  
Low-E4\* Impact-Resistant Glass

## Venting Transom Window Details

Scale 1 1/2" (38) = 1'-0" (305) – 1:8

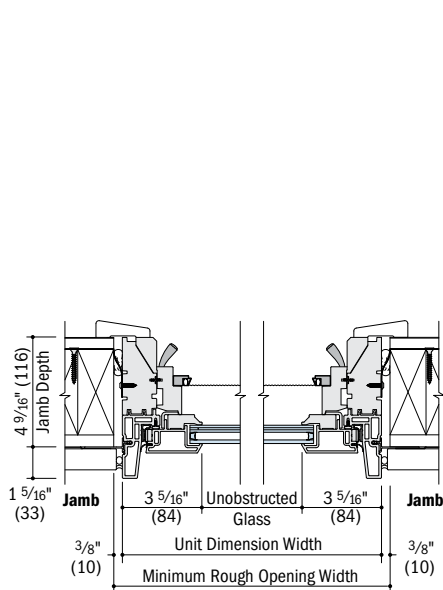

**Horizontal Section**  
Low-E4\* Impact-Resistant Glass

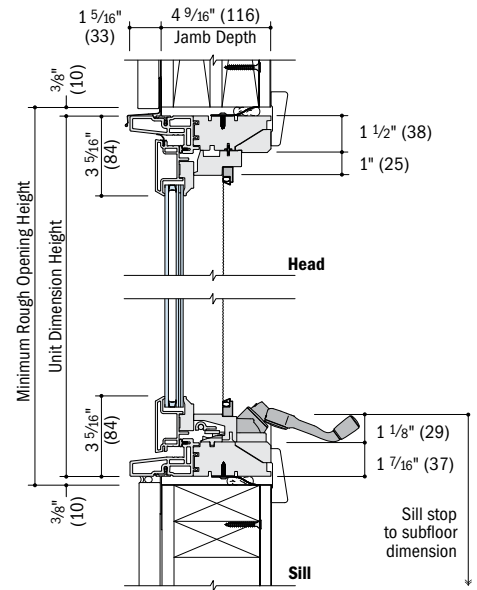
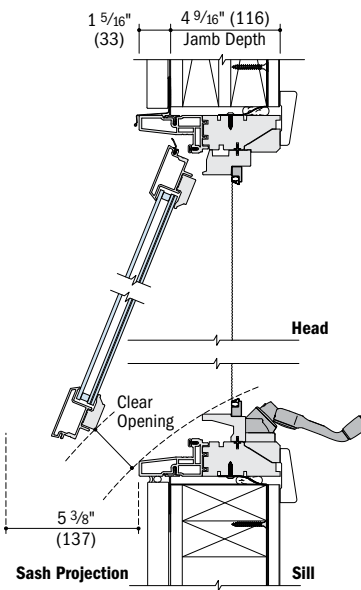

**Vertical Sections**  
Low-E4\* Impact-Resistant Glass

See pages 57-59 for horizontal and vertical joining details.

- 4 9/16" (116) jamb depth measurement is from back side of installation flange.
- Light-colored areas are parts included with window. Dark-colored areas are additional Andersen® parts required to complete window assembly as shown.
- Dimensions in parentheses are in millimeters.
- **Minimum rough opening dimensions may need to be increased to allow for use of building wraps, flashing, sill panning, brackets, fasteners or other items. See installation information on page 170.**
- Details are for illustration only and are not intended to represent product installation methods or materials. Refer to product installation guides at andersenwindows.com.

**Minimum Rough Opening Calculation Examples**

**Single Window**

- 2'-11 1/4" (895) Width dimension, window 1
- + 3/8" (10) Rough opening clearance, side 1
- + 3/8" (10) Rough opening clearance, side 2

---

- 3'-0" (914) Total**

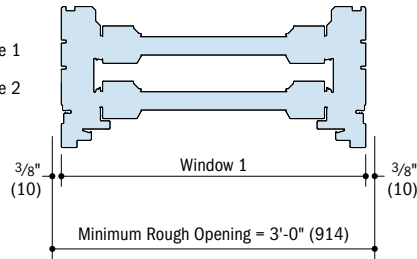

**Two Vertical (ribbon) Joined Windows**

- 2'-11 1/4" (895) Width dimension, window 1
- 2'-11 1/4" (895) Width dimension, window 2
- + 3/8" (10) Rough opening clearance, side 1
- + 3/8" (10) Rough opening clearance, side 2
- + 3/4" (10) Fiberglass joining material, join 1

---

- 6'-0" (1829) Total**

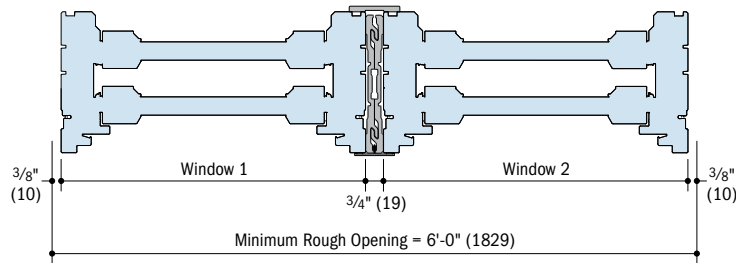

For factory-joined windows, modular sizing allows for easy calculation of minimum rough opening sizes.

**Three Vertical (ribbon) Joined Windows**

- 2'-11 1/4" (895) Width dimension, window 1
- 2'-11 1/4" (895) Width dimension, window 2
- 2'-11 1/4" (895) Width dimension, window 3
- + 3/8" (10) Rough opening clearance, side 1
- + 3/8" (10) Rough opening clearance, side 2
- + 3/4" (19) Fiberglass joining material, join 1
- + 3/4" (19) Fiberglass joining material, join 2

---

- 9'-0" (2743) Total**

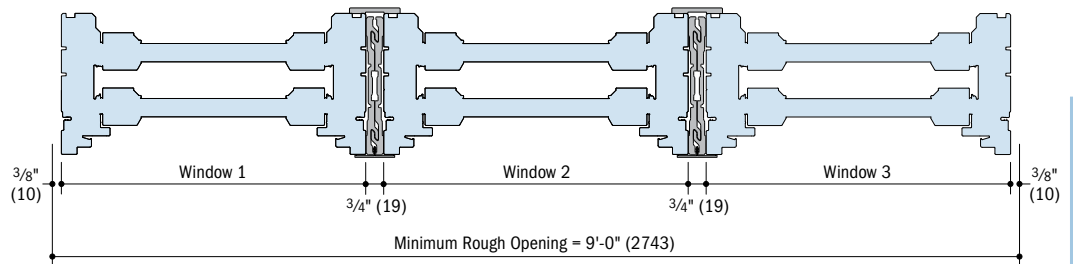

• Dimensions in parentheses are in millimeters.  
 • Minimum rough opening dimensions may need to be increased to allow for use of building wraps, flashing, sill panning, brackets, fasteners or other items. See installation information on page 170.  
 • Details are for illustration only and are not intended to represent product installation methods or materials. Refer to product installation guides at andersenwindows.com.

## Vertical (ribbon) Joining Details

Scale 3" (76) = 1'-0" (305) – 1:4

Windows can be joined to other windows using 3/4" (19) x 5 3/4" (146)

fiberglass joining material for 4 9/16" (116) minimum wall depth.

See page 102 for specialty window joining details.

### Overall Window Dimension Width

Sum of individual window widths plus 3/4" (19).

### Overall Minimum Rough Opening Width

Overall window dimension width plus 3/4" (19).

For more joining information, see the combination designs section starting on page 148.

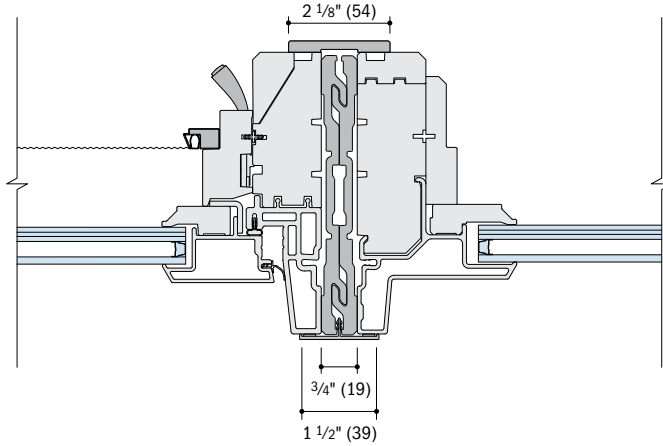

Casement to Picture

## Vertical (ribbon) Fiberglass Joining Details

Scale 1 1/2" (38) = 1'-0" (305) – 1:8

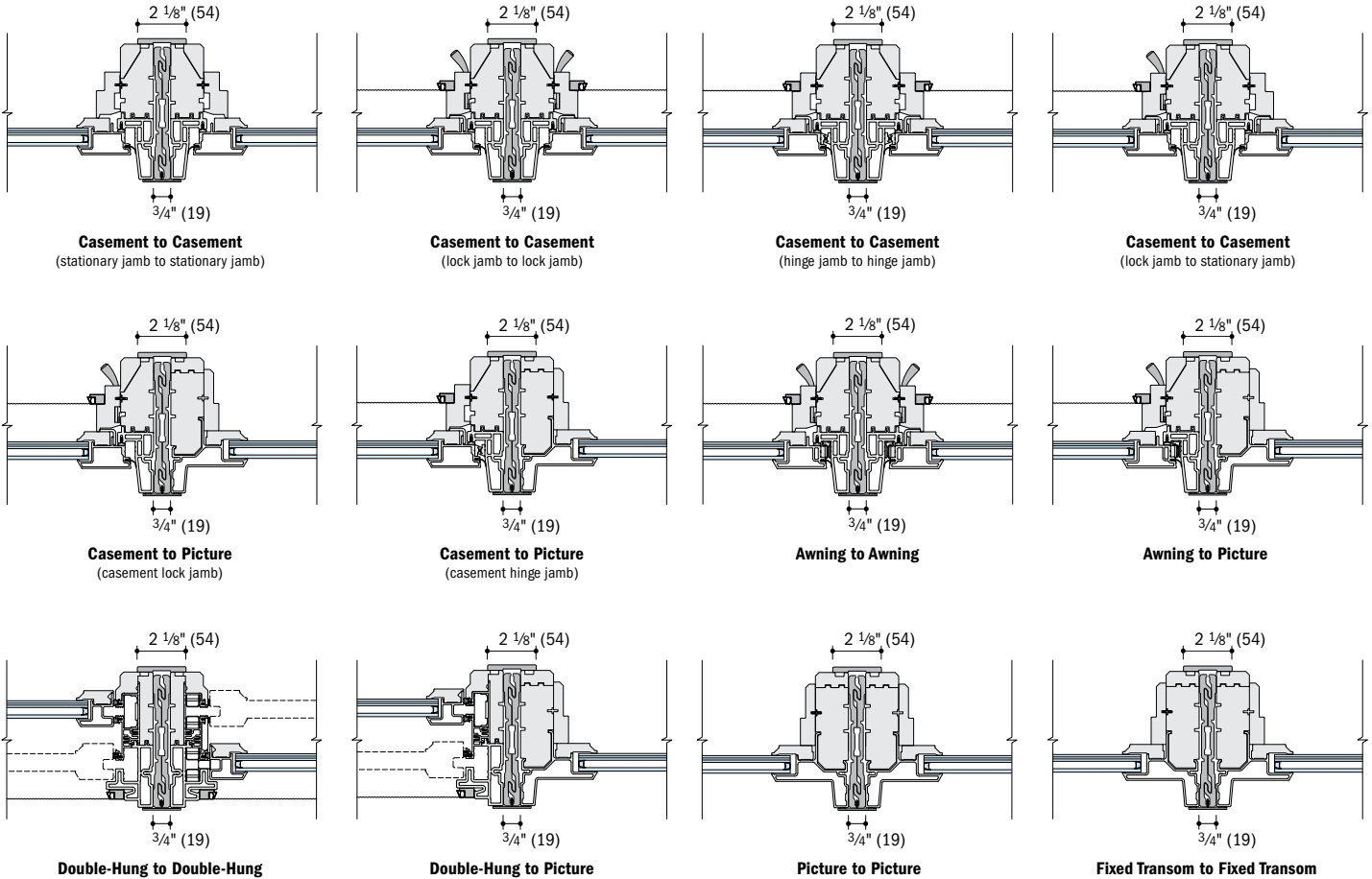

\* Light-colored areas are parts included with window. Dark-colored areas are additional Andersen® parts required to complete window assembly as shown.

\* Dimensions in parentheses are in millimeters.

\* **Minimum rough opening dimensions may need to be increased to allow for use of building wraps, flashing, sill panning, brackets, fasteners or other items. See installation information on page 170.**

\* Details are for illustration only and are not intended to represent product installation methods or materials. Refer to product installation guides at andersenwindows.com.

\* Structural performance of any combination is only as high as the lowest structural performance of any individual window or join in the combination.

\* Andersen® products must be installed and anchored properly according to joining and installation guides to meet rated structural performance. Refer to product joining and installation guides at andersenwindows.com.

**Horizontal (stack) Joining Details**

Scale 3" (76) = 1'-0" (305) – 1:4

Windows can be joined to other windows using 3/4" (19) x 5 3/4" (146)

fiberglass joining material for 4 9/16" (116) minimum wall depth.

See page 102 for specialty window joining details.

**Overall Window Dimension Height**

Sum of individual window heights plus 3/4" (19).

**Overall Minimum Rough Opening Height**

Overall window dimension height plus 3/4" (19).

**For more joining information, see the combination designs section starting on page 148.**

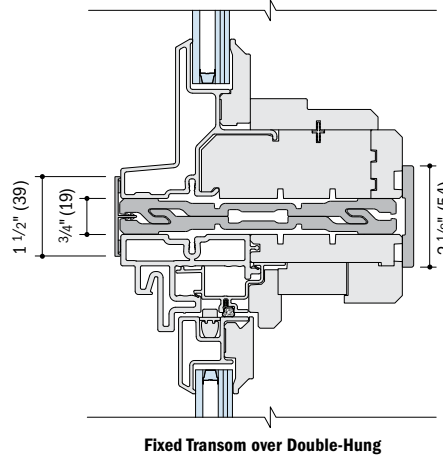

**Horizontal (stack) Fiberglass Joining Details**

Scale 1 1/2" (38) = 1'-0" (305) – 1:8

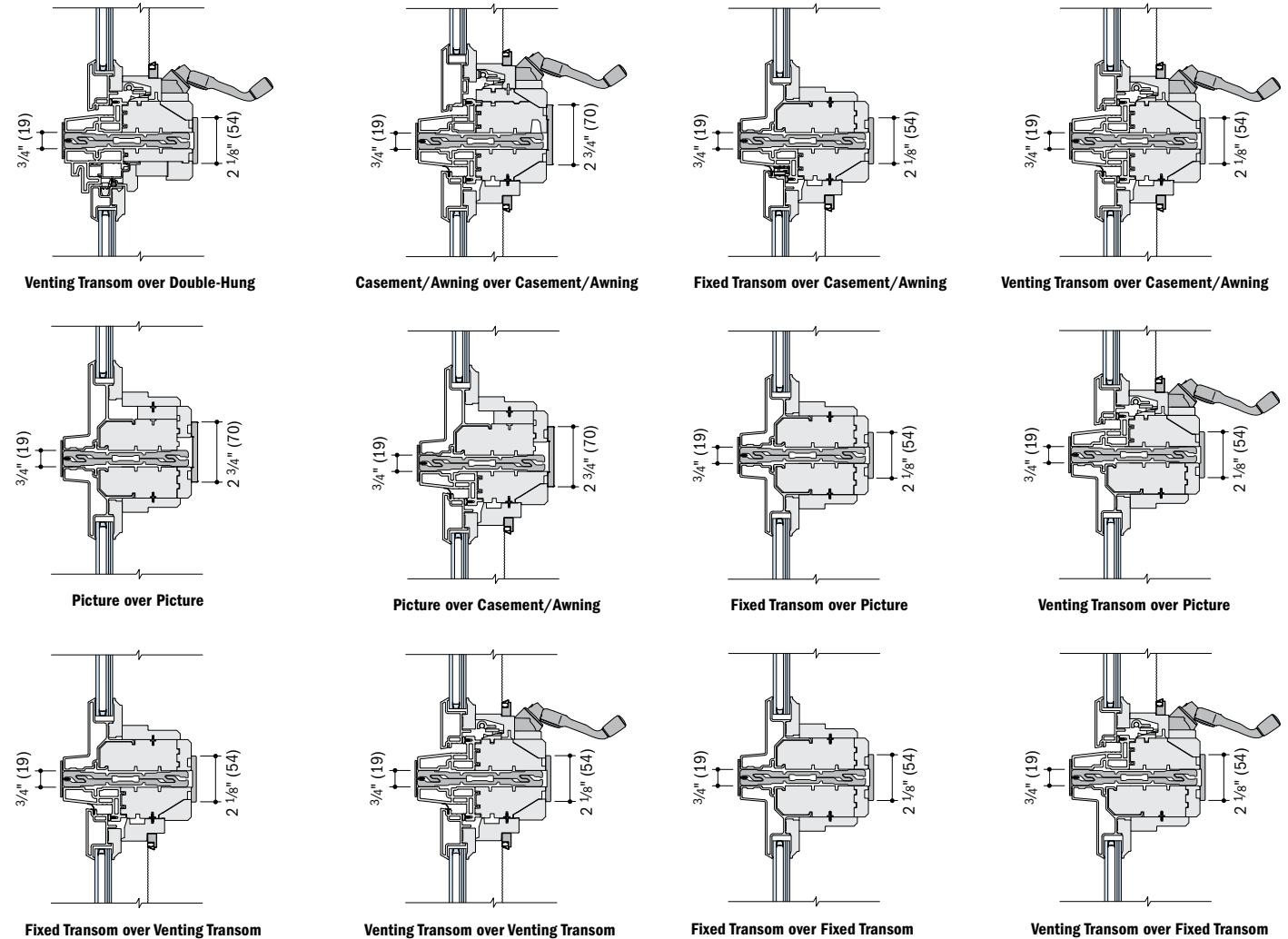

- Light-colored areas are parts included with window. Dark-colored areas are additional Andersen® parts required to complete window assembly as shown.
- Dimensions in parentheses are in millimeters.
- **Minimum rough opening dimensions may need to be increased to allow for use of building wraps, flashing, sill panning, brackets, fasteners or other items. See installation information on page 170.**
- Details are for illustration only and are not intended to represent product installation methods or materials. Refer to product installation guides at andersenwindows.com.
- Structural performance of any combination is only as high as the lowest structural performance of any individual window or join in the combination.
- Andersen® products must be installed and anchored properly according to joining and installation guides to meet rated structural performance. Refer to product joining and installation guides at andersenwindows.com.

**Custom Sizes & Specification Formulas**



A-Series windows are available in 1/8" (3) increments between minimum and maximum widths and heights shown. Some restrictions apply, contact your Andersen supplier for custom-sized specialty windows.

**Casement Windows**

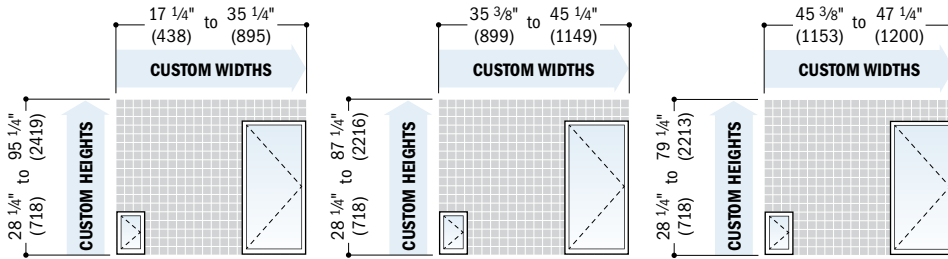

Hinge type for casement windows is based on size and window performance. To determine which clear opening formula to use, first contact an Andersen representative to identify the hinge type.

<p><b>Clear Opening</b></p>	<p>Width = window width - 9.42" (239)                  = window width - 6.76" (172)                  = window width - 10.94" (278)                  = 0.95 x (window width - 9.07" (230))</p> <p>Height = window height - 5.65" (144)</p> <p>10" (254) hinge with wash mode                  10" (254) hinge for widest clear opening                  13" (330) hinge with wash mode                  13" (330) hinge for widest clear opening &amp; control bracket</p>	<p><b>Minimum R.O.</b></p>	<p>Width = window width + 3/4" (19)                  Height = window height + 3/4" (19)</p>
<p><b>Vent Opening</b></p>	<p>Width = window width - 6.54" (169)                  Height = window height - 5.65" (144)</p>	<p><b>Unobstr. Glass</b></p>	<p>Width = window width - 6.65" (169)                  Height = window height - 7.45" (189)</p>

\* All casement windows wider than 2'-3 1/4" (692) and taller than 3'-11 1/4" (1200) meet or exceed clear opening area of 5.7 sq. ft. or .053 m<sup>2</sup>, clear opening width of 20" (508) and clear opening height of 24" (610).

**Awning Windows**

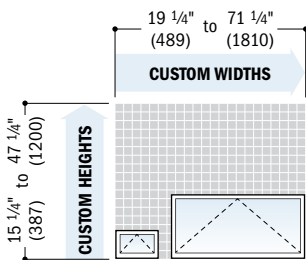

<p><b>Clear Opening</b></p>	<p>Width = window width - 4.94" (125)                  Depth = 5.88" (149)</p>	<p><b>Minimum R.O.</b></p>	<p>Width = window width + 3/4" (19)                  Height = window height + 3/4" (19)</p>
<p><b>Vent Opening</b></p>	<p>Width = window width - 4.94" (125)                  Depth = 5.88" (149)</p>	<p><b>Unobstr. Glass</b></p>	<p>Width = window width - 6.65" (169)                  Height = window height - 7.45" (189)</p>

\* Awning windows do not meet clear opening area of 5.7 sq. ft. or 0.53 m<sup>2</sup>, clear opening width of 20" (508) and clear opening height of 24" (610).

\* Dimensions in parentheses are in millimeters.

\* "Clear Opg." (clear opening) formulas provide dimensions for determining area available for egress. "Vent Opg." (vent opening) formulas provide dimensions for determining area available for passage of air. "Min. R.O." (minimum rough opening) formulas provide minimum rough opening width and height dimensions. "Unobstr. Gls." (unobstructed glass) formulas provide dimensions for determining area available for passage of light.

## Double-Hung Windows

### Equal Sash Ratio

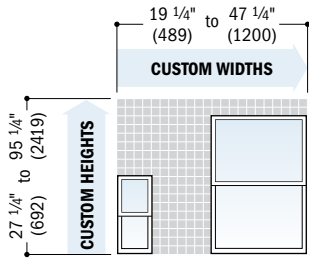

	<b>Clear Opening*</b> Width = window width - 4.06" (103) Height = (window height + 2) - 4.65" (118)		<b>Minimum R.O.</b> Width = window width + 3/4" (19) Height = window height + 3/4" (19)
			<b>Vent Opening*</b> Width = window width - 4.06" (103) Height = (window height + 2) - 3.84" (98)

\*Windows wider than 3'-1 1/4" (946) and taller than 4'-11 1/4" (1505) meet or exceed clear opening area of 5.7 sq. ft. or .053 m<sup>2</sup>, clear opening width of 20" (508) and clear opening height of 24" (610).  
 \*Two locks are standard on all double-hung windows with Stormwatch® Protection.  
 \*Clear opening and venting opening will be reduced for larger sizes with limited sash travel. Contact your Andersen supplier for more information.

### 2:3 Cottage Sash Ratio

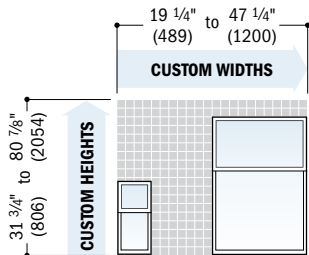

### 3:2 Reverse Cottage Sash Ratio

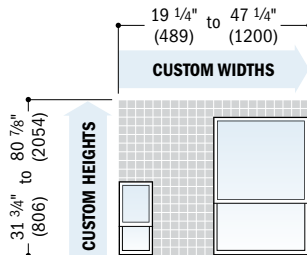

	<b>Clear Opening*</b> Width = window width - 4.06" (103) Height = (window height - 4.18" (106)) x 0.4 - 2.01" (51)		<b>Minimum R.O.</b> Width = window width + 3/4" (19) Height = window height + 3/4" (19)
			<b>Vent Opening*</b> 2:3 Cottage Sash Ratio Width = window width - 4.06" (103) Height = (window height - 4.18" (106)) x 0.4 - 2.01" (51) + 0.8" (20)
	<b>Clear Opening*</b> 3:2 Reverse Cottage Sash Ratio Width = window width - 4.06" (103) Height = (window height - 4.18" (106)) x 0.4 - 2.01" (51) + 2.2" (56)		<b>Minimum R.O.</b> 3:2 Reverse Cottage Sash Ratio Width = window width - 6.65" (169) Upper Sash Height = (window height - 9.65" (245)) x 0.6 Lower Sash Height = (window height - 9.65" (245)) x 0.4 Total Sash Height = window height - 9.65" (245)

\*Two locks are standard on all double-hung windows with Stormwatch® Protection.  
 \*Clear opening and venting opening will be reduced for larger sizes with limited sash travel. Contact your Andersen supplier for more information.

\*Dimensions in parentheses are in millimeters.  
 \*\*Clear Opg\* (clear opening) formulas provide dimensions for determining area available for egress. \*Vent Opg\* (vent opening) formulas provide dimensions for determining area available for passage of air. \*Min. R.O.\* (minimum rough opening) formulas provide minimum rough opening width and height dimensions. \*Unobstr. Gls.\* (unobstructed glass) formulas provide dimensions for determining area available for passage of light.

## Fixed Transom Windows

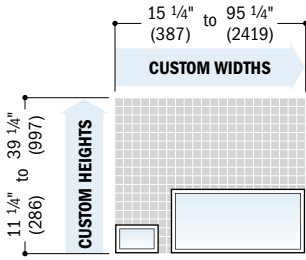

	<b>Minimum R.O.</b> Width = window width + 3/4" (19) Height = window height + 3/4" (19)		<b>Unobstr. Glass</b> Width = window width - 6.65" (169) Height = window height - 6.65" (169)

\* Largest dimensions for fixed transom or picture window are 94 1/4" (2419) x 71 1/4" (1810) or 71 1/4" (1810) x 94 1/4" (2419).

## Venting Transom Windows

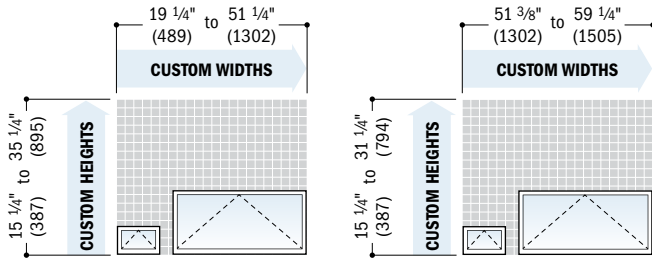

	<b>Clear Opening</b> Width = window width - 4.94" (125) Depth = 5.88" (149)		<b>Minimum R.O.</b> Width = window width + 3/4" (19) Height = window height + 3/4" (19)
	<b>Vent Opening</b> Width = window width - 4.94" (125) Depth = 5.88" (149)		

\* Venting transom windows do not meet clear opening area of 5.7 sq. ft. or 0.53 m<sup>2</sup>, clear opening width of 20" (508) and clear opening height of 24" (610).

## Picture Windows

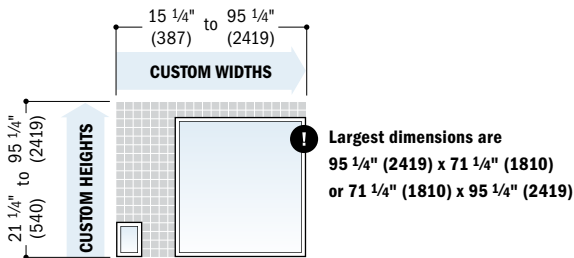

	<b>Minimum R.O.</b> Width = window width + 3/4" (19) Height = window height + 3/4" (19)		<b>Unobstr. Glass</b> Width = window width - 6.65" (169) Height = window height - 7.45" (169)

\* Dimensions in parentheses are in millimeters.

\*\* "Min. R.O." (minimum rough opening) formulas provide minimum rough opening width and height dimensions. "Unobstr. Gls." (unobstructed glass) formulas provide dimensions for determining area available for passage of light.



# SPECIALTY WINDOWS

**Half Circle, Elliptical & Quarter Circle**

Table of Sizes ..... 66-69

Direct-Set Specifications ..... 73

Sash-Set Specifications ..... 74-75

Grille Patterns ..... 69

**Unequal Leg Arch**

Table of Sizes ..... 70-71

Direct-Set Specifications ..... 73-74

Sash-Set Specifications ..... 74

Grille Patterns ..... 71

**Octagon, Circle & Oval**

Table of Sizes ..... 72

Direct-Set Specifications ..... 73

Sash-Set Specifications ..... 75

Grille Patterns ..... 72

**Trapezoid** ..... 75

**Arch**

Table of Sizes ..... 76-88

Direct-Set Specifications ..... 80-81, 85-86

Sash-Set Specifications ..... 86-89

Grille Patterns ..... 97

**Springline™**

Table of Sizes ..... 90-96

Direct-Set Specifications ..... 97-98

Sash-Set Specifications ..... 99-100

Grille Patterns ..... 97

Window Details ..... 101

Joining Details ..... 102

Combination Designs ..... 148

Product Performance ..... 160

**CUSTOM SIZING**  
in 1/8" (3) increments 

Dimensions in parentheses are in millimeters.

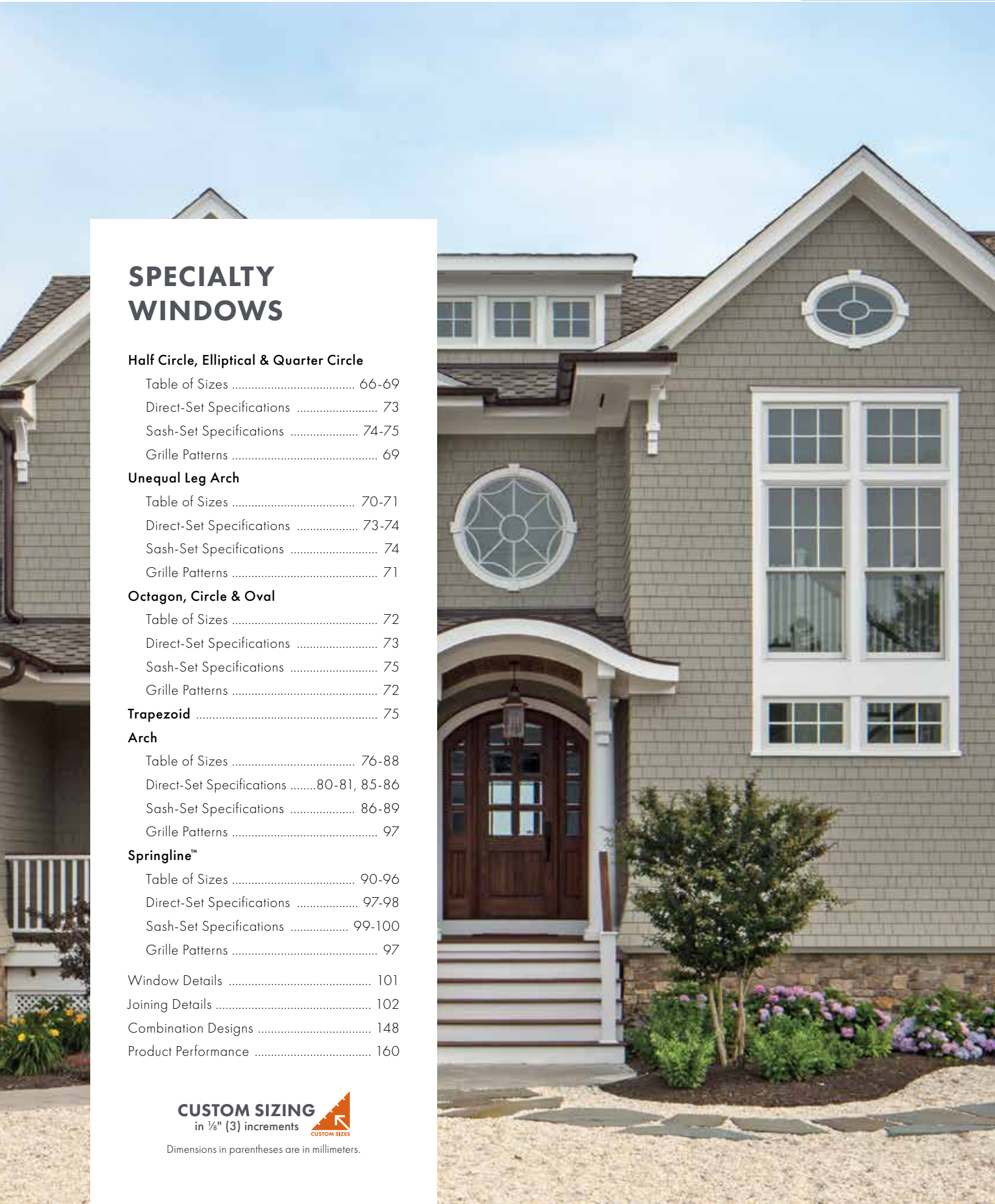

## FEATURES

### FRAME

**A** Frame constructed with a wood core and protected with a heavy-duty extruded aluminum cladding. Standard cladding finish meets AAMA 2604. An optional finish that meets the AAMA 2605 standard is also available. This construction produces a rigid frame and a low-maintenance, durable exterior with no exposed ends.

**B** A vinyl installation flange extends 1 1/2" (38) around the perimeter of the unit to help properly position the unit in the opening.

**C** Factory-applied installation clips are standard for anchoring to the building. Mounted around the perimeter, the clips rotate into position and can be bent into place against the framing members to suit all jamb conditions.



**D** Wood members are treated with a water-repellent preservative for long-lasting\* protection and performance. Radii are made of laminated continuous veneers. Lineal components are solid or engineered wood with a pine core.

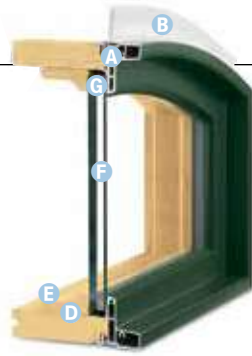

Direct-Set Window

### SASH

Available in direct-set or sash-set construction. Direct-set windows have glass glazed directly into the frame and maximize glass area. Sash-set windows feature a fixed sash and provide common sight lines with other A-Series operating windows. Sash constructed with a wood core and protected with a heavy-duty aluminum cladding. This construction produces a rigid sash and a low-maintenance, durable exterior. Standard cladding has a 70% Kynar® Fluoropolymer coating that meets AAMA 2605.

Traditional architectural style:

- Classic chamfer detailing
- The look of mortise-and-tenon joinery

**E** Natural wood interiors are treated with a water-repellent wood preservative for long-lasting\* protection and performance.

### F GLASS

**F** Impact-resistant glass construction provides industry-leading energy performance, sound control and added security.

High-Performance options include:

- Low-E4® Impact-Resistant glass
- Low-E4 HeatLock® Impact-Resistant glass
- Low-E4 Sun Impact-Resistant glass
- Low-E4 SmartSun™ Impact-Resistant glass
- Low-E4 SmartSun HeatLock Impact-Resistant glass

Tempered laminated and obscure glass options are available, contact your Andersen supplier.

**G** Silicone glazing fillet bead combined with two-sided silicone tape provides superior weathertightness.

A removable translucent film helps shield the glass from damage during delivery and construction and also simplifies finishing at the jobsite.

## ACCESSORIES Sold Separately

### FRAME

#### Extension Jamb

Extension jambs are available in pine, oak, maple, cherry, mahogany\*\* and vertical grain Douglas fir, precut to fit your unit. Available in 1/8" (1.5) increments up to 7 1/8" (181) and can be prefinished in six stain colors, as well as all interior painted options to match the interior of the unit. This option is also available factory applied.

#### Plinth Blocks

For enhancing casing transitions. Decorated with a radial sunburst, they can be reversed to reveal a flush face.



For arch windows, use 2 7/8" x 4" (73 x 102) size plinth block with 2 1/4" (57) and 2 1/2" (64) casing. Use 3 7/8" x 5 1/4" (98 x 133) size with 3 1/2" (89) casing.



For half circle, circle, elliptical and oval windows, use 2 7/8" (73) size plinth block with 2 1/4" (57) and 2 1/2" (64) casing. Use 3 7/8" (98) size with 3 1/2" (89) casing.

## EXTERIOR & INTERIORS

### EXTERIOR COLORS



### INTERIOR WOOD SPECIES



Naturally occurring variations in grain, color and texture of wood make each window one of a kind. All wood interiors are unfinished unless a finish is specified.

### FACTORY-FINISHED INTERIORS

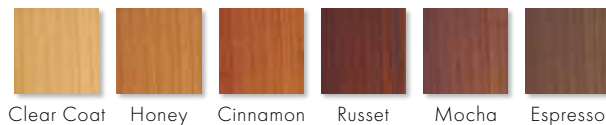

Shown on pine. Available on pine, maple and oak only.

### INTERIOR PAINTED OPTIONS

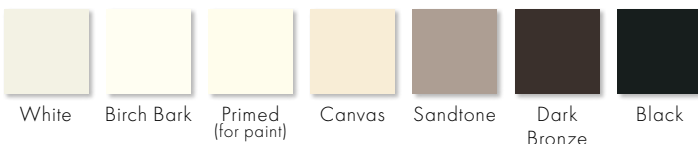

Available on pine. Additional colors to match all 11 exterior colors are also available, contact your Andersen supplier.

Lighthouse indicates differences from standard unit or optional upgrades.

\*Visit [andersenwindows.com/warranty](http://andersenwindows.com/warranty) for details.  
\*\*Actual wood species is either Sapele or Sipo, both non-endangered species grown in Africa, with color and characteristics similar to Central American mahoganies.

Dimensions in parentheses are in millimeters.  
Printing limitations prevent exact replication of colors and finishes. See your Andersen supplier for actual color and finish samples.

**SHAPES**

**Interior Arch Casing**

Available in Colonial or Ranch styles, each arch casing comes with transition blocks or plinth blocks, depending on the product. Additional profiles are also available. For easy integration and consistency, casing dimensions are consistent with Wood Moulding and Millwork Producers Association specifications. Available in pine, maple, oak, cherry, mahogany\* and vertical grain Douglas fir. Additional species are available.



2 1/4" (57) Colonial, WM366



2 1/2" (64) Colonial, WM351



3 1/2" (89) Colonial, WM444



2 1/4" (57) Ranch, WM324

2 1/2" (64) Ranch, WM315

**GRILLES**

Grilles are available in a variety of configurations and widths. See page 15 for details.

**EXTERIOR TRIM**

This product is available with Andersen Exterior Trim. See pages 141-147 for details.

Andersen® A-Series specialty windows are available in a variety of sizes. Profiles may vary dependent upon shape. Contact your Andersen supplier for specific sizes, details and joining information.

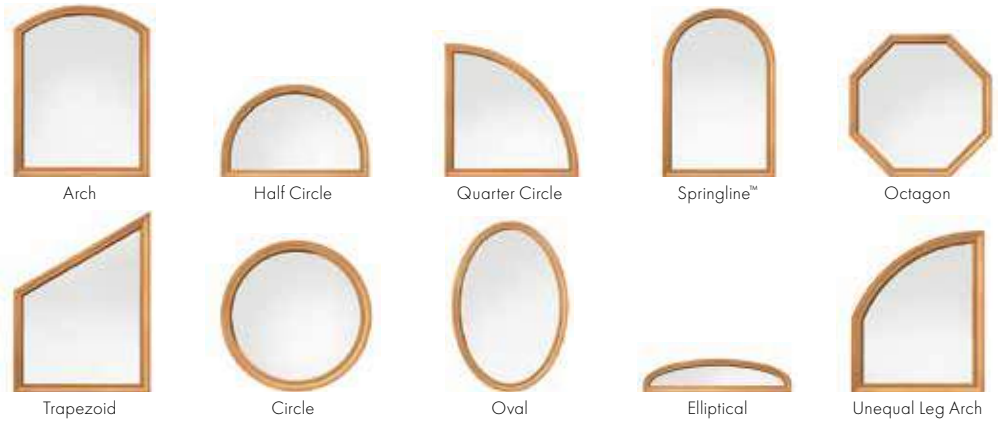

The additional A-Series specialty window shapes below are available by special order.

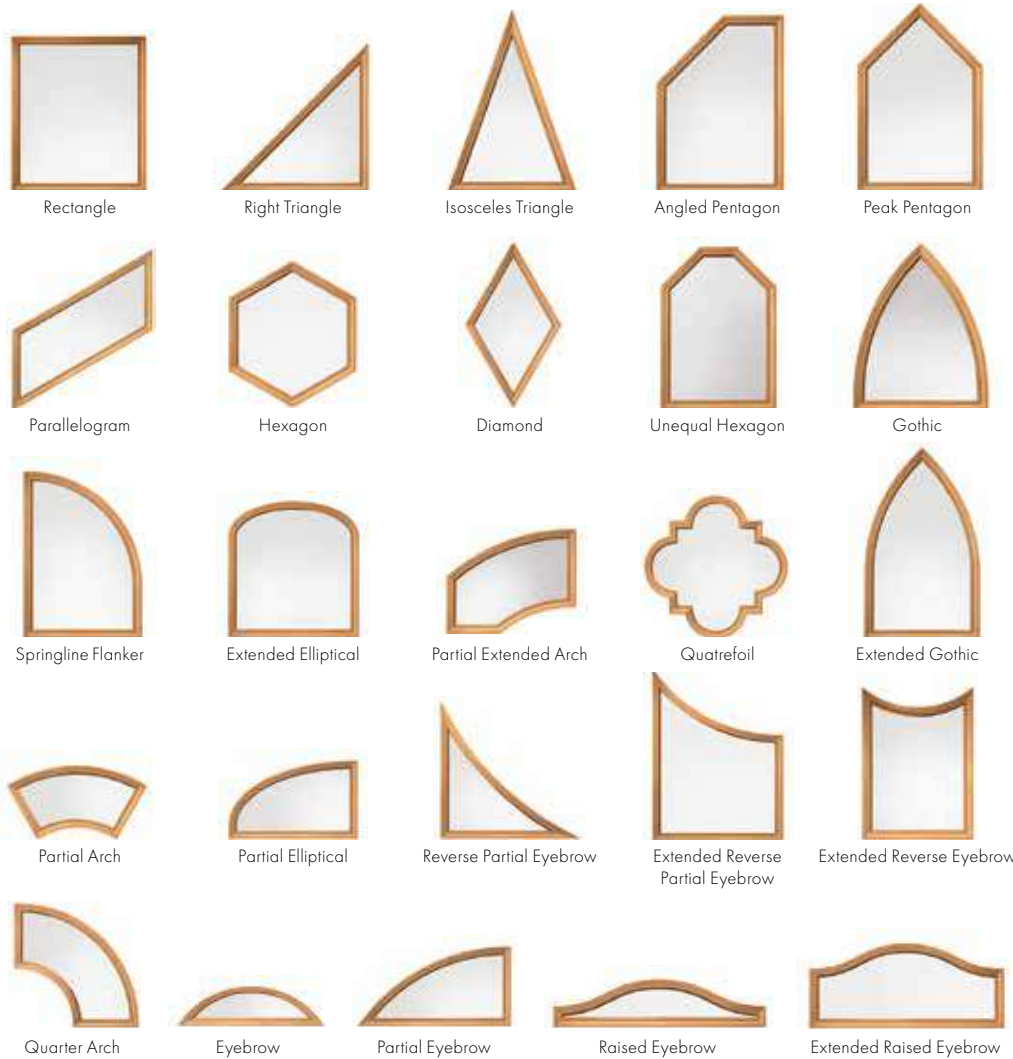

\*Actual wood species is either Sapele or Sipo, both non-endangered species grown in Africa, with color and characteristics similar to Central American mahoganies. Dimensions in parentheses are in millimeters.

## Table of Direct-Set Half Circle Window Sizes

Scale 1/8" (3) = 1'-0" (305) – 1:96

Notes on the next page also apply to this page.

Window Dimension	1'-11 1/4"	2'-0 1/8"	2'-3 1/4"	2'-5 1/4"	2'-6 1/8"
Minimum Rough Opening	2'-0"	2'-1"	2'-4"	2'-6"	2'-7"
Unobstructed Glass	18 7/8"	19 3/4"	22 15/16"	24 15/16"	25 13/16"

11 5/8" (295) 1'-0 3/8" (314) 7 5/8" (194)	1'-0 1/16" (306) 1'-0 13/16" (325) 8 1/16" (205)	1'-1 5/8" (346) 1'-2 3/8" (365) 9 5/8" (244)	1'-2 5/8" (371) 1'-3 3/8" (391) 10 5/8" (270)	1'-3 1/16" (383) 1'-3 13/16" (402) 11 1/16" (281)
ATCTD20	ATCTD21	ATCTD24	ATCTD26	ATCTD27
2'-7 1/4" (794) 2'-8" (813) 27" (685)	2'-8 1/8" (816) 2'-9" (838) 27 13/16" (707)	2'-8 3/8" (822) 2'-9" (838) 28 1/8" (714)	2'-9 1/4" (845) 2'-10" (863) 29" (736)	2'-11 1/4" (895) 3'-0" (914) 31" (787)
1'-3 5/8" (397) 1'-4 3/8" (416) 11 5/8" (295)	1'-4 1/16" (408) 1'-4 13/16" (427) 12 1/16" (306)	1'-4 3/16" (411) 1'-4 15/16" (430) 12 3/16" (310)	1'-4 5/8" (422) 1'-5 3/8" (441) 12 5/8" (321)	1'-5 5/8" (448) 1'-6 3/8" (467) 13 5/8" (346)
ATCTD28	ATCTD29	ATCTD29G*	ATCTD210	ATCTD30
3'-0 1/8" (918) 3'-1" (940) 31 7/8" (810)	3'-1 1/4" (946) 3'-2" (965) 33" (838)	3'-2 1/8" (968) 3'-3" (990) 33 7/8" (861)	3'-2 3/8" (975) 3'-3" (990) 34 1/8" (867)	3'-3 1/4" (997) 3'-4" (1016) 35" (890)
1'-6 1/16" (459) 1'-6 13/16" (478) 14 1/16" (357)	1'-6 5/8" (473) 1'-7 3/8" (492) 14 5/8" (371)	1'-7 1/16" (484) 1'-7 13/16" (503) 15 1/16" (383)	1'-7 3/16" (487) 1'-7 15/16" (506) 15 3/16" (386)	1'-7 5/8" (498) 1'-8 3/8" (518) 15 5/8" (397)
ATCTD31	ATCTD32	ATCTD33	ATCTD33G*	ATCTD34
3'-7 1/4" (1099) 3'-8" (1117) 39 1/16" (992)	3'-8 3/8" (1127) 3'-9" (1143) 40 3/16" (1020)	3'-11 1/4" (1200) 4'-0" (1219) 43 1/16" (1094)	4'-2 3/8" (1280) 4'-3" (1295) 46 3/16" (1174)	4'-3 1/4" (1302) 4'-4" (1321) 47 1/8" (1196)
1'-9 5/8" (549) 1'-10 3/8" (568) 17 5/8" (448)	1'-10 3/16" (564) 1'-10 15/16" (583) 18 3/16" (462)	1'-11 5/8" (600) 2'-0 3/8" (619) 19 5/8" (498)	2'-1 3/16" (640) 2'-1 15/16" (659) 21 3/16" (538)	2'-1 5/8" (651) 2'-2 3/8" (670) 21 5/8" (549)
ATCTD38	ATCTD39	ATCTD40	ATCTD43	ATCTD44
4'-7 1/4" (1403) 4'-8" (1422) 51 1/8" (1298)	4'-11 1/4" (1505) 5'-0" (1524) 55 1/8" (1400)	5'-3 1/4" (1607) 5'-4" (1625) 59 1/8" (1502)	5'-7 1/4" (1708) 5'-8" (1727) 63 1/8" (1603)	
2'-3 5/8" (702) 2'-4 3/8" (721) 23 5/8" (600)	2'-5 5/8" (752) 2'-6 3/8" (772) 25 5/8" (651)	2'-7 5/8" (803) 2'-8 3/8" (822) 27 5/8" (702)	2'-9 5/8" (854) 2'-10 3/8" (873) 29 5/8" (752)	
ATCTD48	ATCTD50	ATCTD54	ATCTD58	
5'-11 1/4" (1810) 6'-0" (1829) 67 1/8" (1705)	6'-3 1/4" (1911) 6'-4" (1930) 71 1/8" (1807)	6'-7 1/4" (2013) 6'-8" (2032) 75 1/8" (1909)	6'-11 1/4" (2115) 7'-0" (2134) 79 1/8" (2010)	
2'-11 5/8" (905) 3'-0 3/8" (924) 31 5/8" (803)	3'-1 5/8" (956) 3'-2 3/8" (975) 33 5/8" (854)	3'-3 5/8" (1006) 3'-4 3/8" (1026) 35 5/8" (905)	3'-5 5/8" (1057) 3'-6 3/8" (1076) 37 5/8" (956)	
ATCTD60	ATCTD64	ATCTD68	ATCTD70	

\*"Window Dimension" always refers to outside frame to frame dimension.  
 \*\*"Minimum Rough Opening" dimensions may need to be increased to allow for use of building wraps, flashing, sill panning, brackets, fasteners or other items. See installation information on page 170.  
 \*Dimensions in parentheses are in millimeters.  
 \*Sized to fit over single-panel, stationary A-Series Frenchwood® gliding patio doors.

**Table of Direct-Set Elliptical Window Sizes**

Scale 1/8" (3) = 1'-0" (305) – 1:96

Window Dimension	3'-11 1/4" (1200)	4'-3 1/4" (1302)	4'-7 1/4" (1403)
<b>Minimum Rough Opening</b>	4'-0" (1219)	4'-4" (1321)	4'-8" (1423)
Unobstructed Glass	41 9/16" (1056)	45 3/4" (1162)	50 3/8" (1280)

  

11 7/8" (302)	1'-0 5/8" (321)	7 7/8" (200)		<b>ATETD40</b>
1'-0 5/8" (321)	1'-1 3/8" (340)	8 5/8" (219)		<b>ATETD44</b>
1'-1 1/4" (337)	1'-2" (356)	9 1/4" (235)		<b>ATETD48</b>
4'-11 1/4" (1505)	5'-0" (1524)	54 11/16" (1390)		<b>ATETD50</b>
1'-2" (356)	1'-2 3/4" (375)	10" (254)		<b>ATETD54</b>
1'-2 3/4" (375)	1'-3 1/2" (394)	10 3/4" (273)		<b>ATETD58</b>
1'-3 1/2" (394)	1'-4 1/4" (413)	11 1/2" (292)		<b>ATETD60</b>
5'-11 1/4" (1810)	6'-0" (1828)	66 13/16" (1696)		<b>ATETD64</b>
1'-4 7/8" (429)	1'-5 5/8" (448)	12 7/8" (327)		<b>ATETD68</b>
1'-4 7/8" (429)	1'-5 5/8" (448)	12 7/8" (327)		<b>ATETD70</b>
1'-5 5/8" (448)	1'-6 3/8" (467)	13 5/8" (346)		<b>ATETD74</b>
6'-11 1/4" (2115)	7'-0" (2134)	79 3/16" (2011)		<b>ATETD78</b>
1'-6 3/8" (467)	1'-7 1/8" (486)	14 3/8" (365)		<b>ATETD80</b>
1'-6 3/8" (467)	1'-7 1/8" (486)	14 3/8" (365)		<b>ATETD84</b>
7'-10 7/16" (2399)	7'-11" (2413)	90 1/16" (2288)		<b>ATETD88</b>
1'-7" (483)	1'-7 3/4" (502)	15" (381)		<b>ATETD90</b>
1'-7" (483)	1'-7 3/4" (502)	15" (381)		<b>ATETD94</b>
7'-11 1/4" (2419)	8'-0" (2438)	90 7/8" (2309)		<b>ATETD98</b>
1'-8 3/8" (518)	1'-9 1/8" (537)	16 3/8" (416)		<b>ATETD100</b>
1'-8 3/8" (518)	1'-9 1/8" (537)	16 3/8" (416)		<b>ATETD104</b>
8'-10 7/16" (2704)	8'-11" (2718)	102 1/8" (2594)		<b>ATETD108</b>
1'-10 1/2" (572)	1'-11 1/4" (591)	18 1/2" (470)		<b>ATETD110</b>



**Custom-size windows are available in 1/8" (3) increments.**

Contact your Andersen supplier for more information.

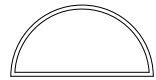

Direct-Set Half Circle

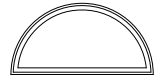

Sash-Set Half Circle



Direct-Set Elliptical



Sash-Set Elliptical

**Direct-set half circle (ATCTD)**

**and (ATETD) elliptical window sizes shown.**

Use window and minimum rough opening dimensions shown for sash-set half circle (ATCT) and elliptical (ATET) window sizes. For sash-set unobstructed glass dimensions, see page 74.

Details shown on page 101.

Grille patterns shown on page 69.

• "Window Dimension" always refers to outside frame to frame dimension.  
 • "Minimum Rough Opening" dimensions may need to be increased to allow for use of building wraps, flashing, sill panning, brackets, fasteners or other items. See installation information on page 170.  
 • Dimensions in parentheses are in millimeters.

## Table of Direct-Set Quarter Circle Window Sizes

Scale 1/8" (3) = 1'-0" (305) – 1:96

Notes on the next page also apply to this page.

Window Dimension	1'-11 1/4"	2'-0 1/8"	2'-3 1/4"	2'-5 1/4"	2'-6 1/8"
Minimum Rough Opening	2'-0"	2'-1"	2'-4"	2'-6"	2'-7"
Unobstructed Glass	19 3/16"	20 1/16"	23 3/16"	25 3/16"	26 1/16"

1'-11 1/4"	2'-0 1/8"	2'-3 1/4"	2'-5 1/4"	2'-6 1/8"
(591)	(613)	(692)	(743)	(765)
2'-0"	2'-1"	2'-4"	2'-6"	2'-7"
(610)	(635)	(711)	(762)	(787)
19 3/16"	20 1/16"	23 3/16"	25 3/16"	26 1/16"
(487)	(509)	(589)	(639)	(662)
ATQCTD20	ATQCTD21	ATQCTD24	ATQCTD26	ATQCTD27
2'-8 3/8"	2'-9 1/4"	2'-11 1/4"	3'-0 1/8"	3'-1 1/4"
(822)	(845)	(895)	(918)	(946)
2'-9"	2'-10"	3'-0"	3'-1"	3'-2"
(838)	(864)	(914)	(940)	(965)
28 5/16"	29 3/16"	31 3/16"	32 1/16"	33 3/16"
(719)	(741)	(792)	(814)	(843)
ATQCTD29G*	ATQCTD210	ATQCTD30	ATQCTD31	ATQCTD32
3'-3 1/4"	3'-5 1/4"	3'-7 1/4"	3'-8 3/8"	3'-11 1/4"
(997)	(1048)	(1099)	(1127)	(1200)
3'-4"	3'-6"	3'-8"	3'-9"	4'-0"
(1016)	(1067)	(1118)	(1143)	(1219)
35 3/16"	37 3/16"	39 3/16"	40 5/16"	43 3/16"
(894)	(945)	(996)	(1024)	(1097)
ATQCTD34	ATQCTD36	ATQCTD38	ATQCTD39	ATQCTD40
4'-7 1/4"	4'-11 1/4"	5'-3 1/4"	5'-7 1/4"	
(1403)	(1505)	(1607)	(1708)	
4'-8"	5'-0"	5'-4"	5'-8"	
(1422)	(1524)	(1626)	(1727)	
51 1/4"	55 1/4"	59 1/4"	63 1/4"	
(1301)	(1402)	(1504)	(1606)	
ATQCTD48	ATQCTD50	ATQCTD54	ATQCTD58	
6'-3 1/4"	6'-7 1/4"	6'-11 1/4"		
(1911)	(2013)	(2115)		
6'-4"	6'-8"	7'-0"		
(1930)	(2032)	(2134)		
71 1/4"	75 1/4"	79 1/4"		
(1809)	(1911)	(2012)		
ATQCTD64	ATQCTD68	ATQCTD70		
6'-6 1/4"	6'-7 1/4"	6'-11 1/4"		
(1911)	(2013)	(2115)		
6'-6"	6'-8"	7'-0"		
(1930)	(2032)	(2134)		
71 1/4"	75 1/4"	79 1/4"		
(1809)	(1911)	(2012)		

\* "Window Dimension" always refers to outside frame to frame dimension.  
 • "Minimum Rough Opening" dimensions may need to be increased to allow for use of building wraps, flashing, sill panning, brackets, fasteners or other items. See installation information on page 170.  
 • Dimensions in parentheses are in millimeters.  
 • Sized to fit over single-panel, stationary A-Series Frenchwood® gliding patio doors.

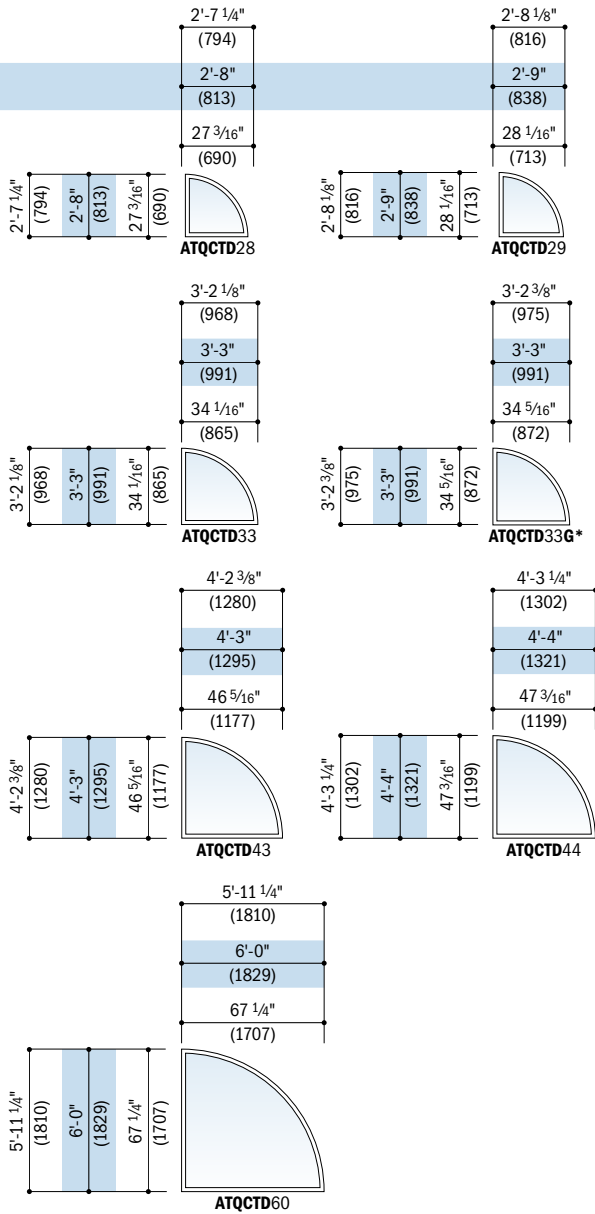

Custom-size windows are available in 1/8" (3) increments.

Contact your Andersen supplier for more information.

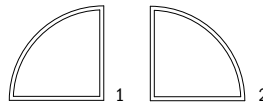

Direct-Set Quarter Circle

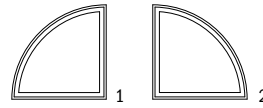

Sash-Set Quarter Circle

**Direct-set (ATQCTD) window sizes shown.** Choose left facing (1) or right facing (2) as viewed from the exterior. Use window and minimum rough opening dimensions shown for sash-set (ATQCT) window sizes.

For sash-set unobstructed glass dimensions, see page 75.

Details shown on page 101. Grille patterns shown below.

### Grille Patterns

	Colonial	Renaissance	Sunburst
<b>Half Circle</b>			
<b>Quarter Circle</b>			
<b>Elliptical</b>			

**Number of lights and overall pattern varies with window size. Patterns**

**are not available in all configurations.** Specified equal light and custom patterns are also available. For more information on divided light, see page 15 or visit [andersenwindows.com/grilles](http://andersenwindows.com/grilles).

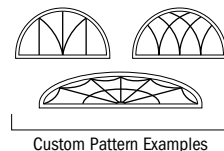

Custom Pattern Examples

\*\*"Window Dimension" always refers to outside frame to frame dimension.  
 ••"Minimum Rough Opening" dimensions may need to be increased to allow for use of building wraps, flashing, sill panning, brackets, fasteners or other items. See installation information on page 170.  
 • Dimensions in parentheses are in millimeters.  
 • Sized to fit over single-panel, stationary A-Series Frenchwood® gliding patio doors.

## Table of Direct-Set Unequal Leg Arch Window Sizes

Scale 1/8" (3) = 1'-0" (305) – 1:96

Notes on the next page also apply to this page.

Window Dimension	1'-3 1/4" (387)	1'-7 1/4" (489)	1'-11 1/4" (591)	2'-0 1/8" (613)	2'-3 1/4" (692)	2'-5 1/4" (743)	2'-6 1/8" (765)	2'-7 1/4" (794)	2'-8 1/8" (816)	2'-8 3/8" (822)
Minimum Rough Opening	1'-4" (406)	1'-8" (508)	2'-0" (610)	2'-1" (635)	2'-4" (711)	2'-6" (762)	2'-7" (787)	2'-8" (813)	2'-9" (838)	2'-9" (838)

		CUSTOM SIZES AVAILABLE										
		36" (914)	42" (1067)	48" (1219)	60" (1524)	60" (1524)	60" (1524)	66" (1676)	66" (1676)	66" (1676)	66" (1676)	
		Radius	Chord Height									
		3 3/8" (86)	4 5/8" (118)	6" (152)	5 1/16" (129)	6 1/2" (166)	7 5/8" (194)	7 1/4" (185)	7 1/8" (181)	8 3/8" (212)	8 1/2" (216)	
Window Dimension	1'-7 1/4" (489)	15 7/8" (403)	14 5/8" (371)	13 1/4" (337)	14 3/16" (360)	12 3/4" (323)	11 5/8" (295)	12" (304)	12 1/8" (308)	10 7/8" (277)	10 3/4" (273)	
	1'-9 1/4" (437)	17 7/8" (454)	16 5/8" (421)	15 1/4" (387)		14 3/4" (374)	13 5/8" (346)		14 1/8" (359)			
	1'-11 1/4" (591)	19 7/8" (505)	18 5/8" (472)	17 1/4" (438)	18 3/16" (462)	16 3/4" (425)	15 5/8" (397)	16" (406)	16 1/8" (410)	14 7/8" (379)	14 3/4" (375)	
	2'-3 1/4" (692)	23 7/8" (606)	22 5/8" (574)	21 1/4" (540)	22 3/16" (564)	20 3/4" (526)	19 5/8" (498)	20" (507)	20 1/8" (511)	18 7/8" (480)	18 3/4" (476)	
	2'-7 1/4" (794)	27 7/8" (708)	26 5/8" (675)	25 1/4" (641)	26 3/16" (665)	24 3/4" (628)	23 5/8" (600)	24" (609)	24 1/8" (613)	22 7/8" (582)	22 3/4" (578)	
	2'-11 1/4" (895)	31 7/8" (810)	30 5/8" (777)	29 1/4" (743)	30 3/16" (767)	28 3/4" (729)	27 5/8" (702)	28" (710)	28 1/8" (714)	26 7/8" (683)	26 3/4" (679)	
Minimum Rough Opening	3'-3 1/4" (997)	3'-7 1/4" (1099)	3'-8 3/8" (1127)	3'-11 1/4" (1200)	4'-2 3/8" (1280)	4'-3 1/4" (1302)	4'-3" (1295)	4'-3 1/4" (1302)	4'-4" (1321)	4'-7 1/4" (1403)	4'-8" (1422)	

		CUSTOM SIZES AVAILABLE										
		84" (2133)	96" (2438)	96" (2438)	96" (2438)	108" (2743)	108" (2743)	108" (2743)	120" (3048)			
		Radius	Chord Height									
		9 3/4" (247)	10 1/4" (261)	10 7/8" (276)	12 1/16" (316)	12 1/2" (317)	12 15/16" (329)	13 1/2" (342)				
Window Dimension	1'-7 1/4" (489)	9 1/2" (242)	9" (228)	8 3/8" (213)								
	1'-9 1/4" (437)	11 1/2" (293)	11" (279)		8 13/16" (224)							
	1'-11 1/4" (591)	13 1/2" (344)	13" (329)	12 3/8" (314)	10 13/16" (275)	10 3/4" (274)	10 5/16" (262)	8 5/16" (211)	7 3/4" (198)			
	2'-3 1/4" (692)	17 1/2" (445)	17" (431)	16 3/8" (416)	14 13/16" (376)	14 3/4" (375)	14 5/16" (364)	13 3/4" (350)	9 3/4" (248)			
	2'-7 1/4" (794)	21 1/2" (547)	21" (533)	20 3/8" (518)	18 13/16" (478)	18 3/4" (477)	18 5/16" (465)	17 3/4" (452)	17 3/4" (452)			
	2'-11 1/4" (895)	25 1/2" (648)	25" (634)	24 3/8" (619)	22 13/16" (579)	22 3/4" (579)	22 5/16" (567)	21 3/4" (553)	21 3/4" (553)			
Minimum Rough Opening	3'-4" (1016)	3'-8" (1118)	3'-9" (1143)	4'-0" (1219)	4'-3" (1295)	4'-3" (1295)	4'-4" (1321)	4'-4" (1321)	4'-8" (1422)			

• "Window Dimension" always refers to outside frame to frame dimension.  
 • "Minimum Rough Opening" dimensions may need to be increased to allow for use of building wraps, flashing, sill panning, brackets, fasteners or other items. See installation information on page 170.  
 • Dimensions in parentheses are in millimeters.  
 • Sized to fit over single-panel, stationary A-Series Frenchwood® gliding patio doors.



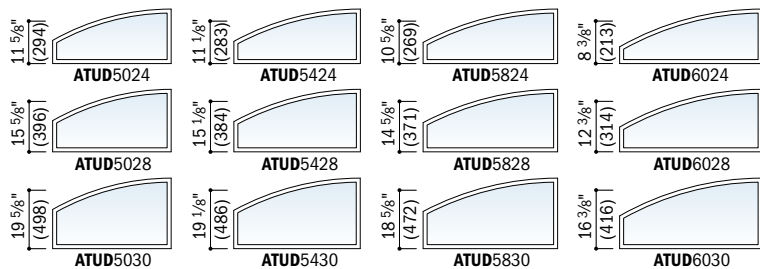
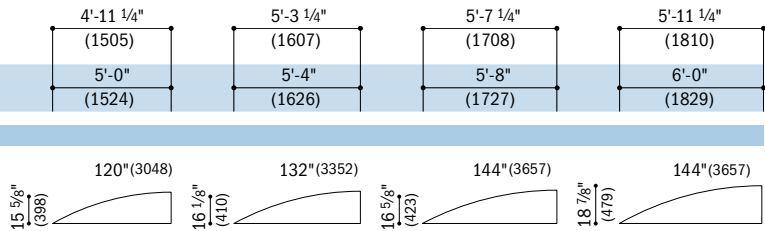
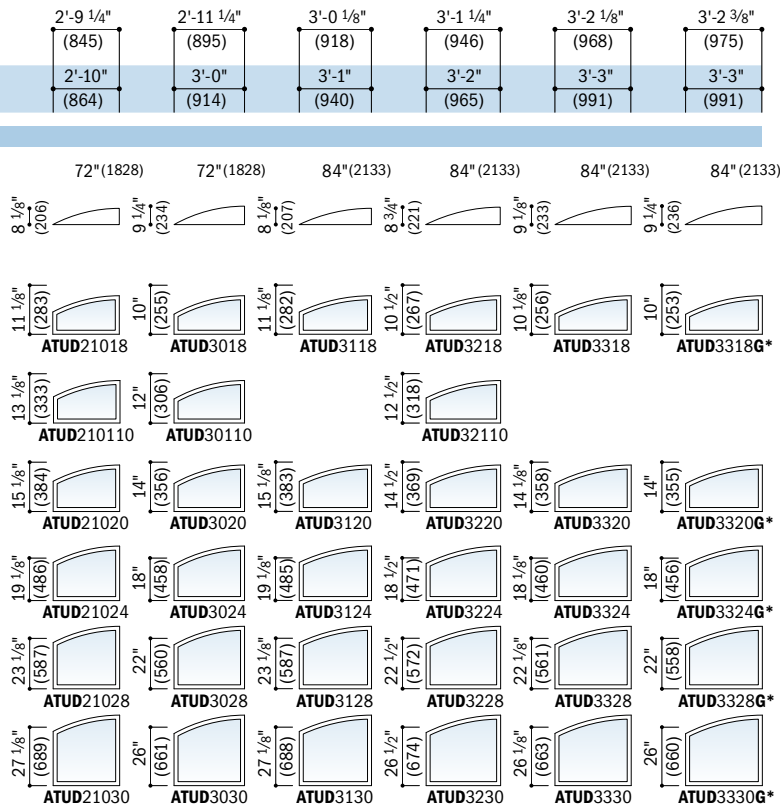

\*Window Dimension\* always refers to outside frame to frame dimension.  
 • \*Minimum Rough Opening\* dimensions may need to be increased to allow for use of building wraps, flashing, sill panning, brackets, fasteners or other items. See installation information on page 170.  
 • Dimensions in parentheses are in millimeters.  
 \*Sized to fit over single-panel, stationary A-Series Frenchwood® gliding patio doors.



Custom-size windows are available in 1/8" (3) increments.  
 Contact your Andersen supplier for more information.

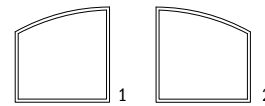

Direct-Set Unequal Leg Arch

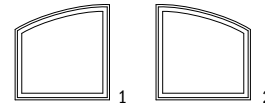

Sash-Set Unequal Leg Arch

**Direct-set (ATUD) window sizes shown.** Choose left facing (1) or right facing (2) as viewed from the exterior. Use window and minimum rough opening dimensions shown for sash-set (ATU) window sizes. For sash-set unobstructed glass dimensions, see page 74.

Details shown on page 101.

**Grille Patterns**

	Colonial	Renaissance	Sunburst
Unequal Leg Arch			

**Number of lights and overall pattern varies with window size. Patterns are not available in all configurations.** Specified equal light and custom patterns are also available. For more information on divided light, see page 15 or visit [andersenwindows.com/grilles](http://andersenwindows.com/grilles).

## Table of Direct-Set Octagon Window Sizes

Scale 1/8" (3) = 1'-0" (305) – 1:96

Window Dimension	1'-11 1/4" (591)	2'-3 1/4" (692)	2'-11 1/4" (895)	3'-11 1/4" (1200)	5'-11 1/4" (1810)
<b>Minimum Rough Opening</b>	2'-0" (610)	2'-4" (711)	3'-0" (914)	4'-0" (1219)	6'-0" (1829)
Unobstructed Glass	19 1/4" (489)	23 1/4" (591)	31 1/4" (794)	43 1/4" (1099)	67 1/4" (1708)

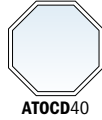

## Table of Direct-Set Circle Window Sizes

Scale 1/8" (3) = 1'-0" (305) – 1:96

Window Dimension	1'-11 1/4" (591)	2'-3 1/4" (692)	2'-11 1/4" (895)	3'-11 1/4" (1200)	5'-11 1/4" (1810)
<b>Minimum Rough Opening</b>	2'-0" (610)	2'-4" (711)	3'-0" (914)	4'-0" (1219)	6'-0" (1829)
Unobstructed Glass	19 1/4" (489)	23 1/4" (591)	31 1/4" (794)	43 1/4" (1099)	67 1/4" (1708)



**Custom-size octagon and circle windows are available in 1/8" (3) increments.** Contact your Andersen supplier for more information. Oval windows are not available in custom sizes.

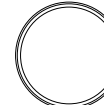
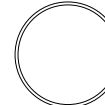
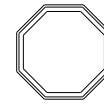
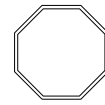

**Direct-set octagon (ATOCD) and circle (ACRD) window sizes shown.** Use window and minimum rough opening dimensions shown for sash-set octagon (ATOC) and sash-set circle (ACR) window sizes. For sash-set unobstructed glass dimensions, see page 75.

## Table of Direct-Set Oval Window Sizes

Scale 1/8" (3) = 1'-0" (305) – 1:96

Window Dimension	1'-7 1/4" (489)	1'-11 1/4" (591)	2'-11 1/4" (895)
<b>Minimum Rough Opening</b>	1'-8" (508)	2'-0" (610)	3'-0" (914)
Unobstructed Glass	15 1/4" (387)	19 1/4" (489)	31 1/4" (794)

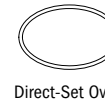
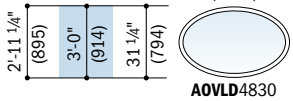
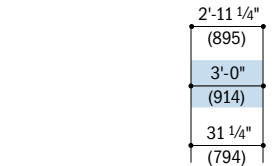
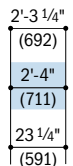
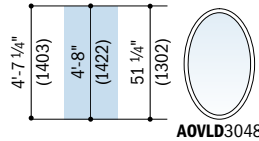
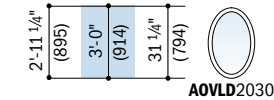
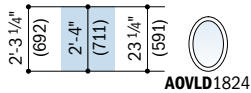

Oval windows are available direct-set only and can be installed in a vertical or horizontal orientation.

Details shown on page 101.

Grille patterns are available in Renaissance, colonial, sunburst, specified equal light and custom patterns.

For more information on divided light, see page 15 or visit [andersenwindows.com/grilles](http://andersenwindows.com/grilles).

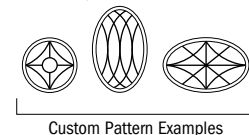
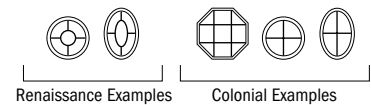

\* "Window Dimension" always refers to outside frame to frame dimension.  
 \* "Minimum Rough Opening" dimensions may need to be increased to allow for use of building wraps, flashing, sill panning, brackets, fasteners or other items. See installation information on page 170.  
 \* Dimensions in parentheses are in millimeters.

**Direct-Set Half Circle Window Area Specifications**

Window Number	Glass Area Sq. Ft./ (m <sup>2</sup> )
ATCTD20	0.75 (0.07)
ATCTD21	0.83 (0.08)
ATCTD24	1.15 (0.11)
ATCTD26	1.39 (0.13)
ATCTD27	1.50 (0.14)
ATCTD28	1.65 (0.15)
ATCTD29	1.77 (0.16)
ATCTD29G	1.80 (0.17)
ATCTD210	1.93 (0.18)
ATCTD30	2.23 (0.21)
ATCTD31	2.37 (0.22)
ATCTD32	2.55 (0.24)
ATCTD33	2.70 (0.25)
ATCTD33G	2.75 (0.26)
ATCTD34	2.90 (0.27)
ATCTD38	3.66 (0.34)
ATCTD39	3.89 (0.36)
ATCTD40	4.50 (0.42)
ATCTD43	5.22 (0.48)
ATCTD44	5.43 (0.50)
ATCTD48	6.45 (0.60)
ATCTD50	7.56 (0.70)
ATCTD54	8.75 (0.81)
ATCTD58	10.03 (0.93)
ATCTD60	11.40 (1.06)
ATCTD64	12.86 (1.19)
ATCTD68	14.40 (1.34)
ATCTD70	16.03 (1.49)

**Direct-Set Elliptical Window Area Specifications**

Window Number	Glass Area Sq. Ft./ (m <sup>2</sup> )
ATETD40	1.69 (0.16)
ATETD44	2.01 (0.19)
ATETD48	2.57 (0.24)
ATETD50	2.86 (0.27)
ATETD54	3.41 (0.32)
ATETD58	3.98 (0.37)
ATETD60	4.27 (0.40)
ATETD64	4.82 (0.45)
ATETD68	5.60 (0.52)
ATETD70	6.26 (0.58)
ATETD74	6.62 (0.62)
ATETD711	7.92 (0.74)
ATETD80	8.00 (0.74)
ATETD811	10.13 (0.94)

**Direct-Set Quarter Circle Window Area Specifications**

Window Number	Glass Area Sq. Ft./ (m <sup>2</sup> )
ATQCTD20	1.90 (0.18)
ATQCTD21	2.08 (0.19)
ATQCTD24	2.80 (0.26)
ATQCTD26	3.32 (0.31)
ATQCTD27	3.56 (0.33)
ATQCTD28	3.88 (0.36)

Window Number	Glass Area Sq. Ft./ (m <sup>2</sup> )
ATQCTD29	4.14 (0.38)
ATQCTD29G	4.22 (0.39)
ATQCTD210	4.49 (0.42)
ATQCTD30	5.13 (0.48)
ATQCTD31	5.43 (0.50)
ATQCTD32	5.83 (0.54)
ATQCTD33	6.14 (0.57)
ATQCTD33G	6.23 (0.58)
ATQCTD34	6.56 (0.61)
ATQCTD36	7.34 (0.68)
ATQCTD38	8.16 (0.76)
ATQCTD39	8.64 (0.80)
ATQCTD40	9.94 (0.92)
ATQCTD43	11.45 (1.06)
ATQCTD44	11.89 (1.10)
ATQCTD48	14.01 (1.30)
ATQCTD50	16.31 (1.52)
ATQCTD54	18.79 (1.75)
ATQCTD58	21.44 (1.99)
ATQCTD60	24.26 (2.25)

**Direct-Set Octagon Window Area Specifications**

Window Number	Glass Area Sq. Ft./ (m <sup>2</sup> )
ATOCD20	2.13 (0.20)
ATOCD24	3.11 (0.29)
ATOCD30	5.62 (0.52)
ATOCD40	10.76 (1.00)
ATOCD60	26.02 (2.42)

**Direct-Set Circle & Oval Window Area Specifications**

Window Number	Glass Area Sq. Ft./ (m <sup>2</sup> )
ACRD20	2.02 (0.19)
ACRD24	2.95 (0.27)
ACRD30	5.33 (0.50)
ACRD40	10.20 (0.95)
ACRD60	24.67 (2.29)
AOVLD1824/AOVLD2418	1.93 (0.18)
AOVLD2030/AOVLD3020	3.27 (0.30)
AOVLD3048/AOVLD4830	8.71 (0.81)

**Direct-Set Unequal Leg Arch Window Area Specifications**

Window Number	Glass Area Sq. Ft./ (m <sup>2</sup> )
ATUD1418	1.11 (0.10)
ATUD14110	1.27 (0.12)
ATUD1420	1.42 (0.13)
ATUD1424	1.74 (0.16)
ATUD1428	2.05 (0.19)
ATUD1430	2.36 (0.22)
ATUD1818	1.46 (0.14)
ATUD18110	1.67 (0.16)
ATUD1820	1.89 (0.18)

Window Number	Glass Area Sq. Ft./ (m <sup>2</sup> )
ATUD1824	2.31 (0.21)
ATUD1828	2.73 (0.25)
ATUD1830	3.16 (0.29)
ATUD2018	1.79 (0.17)
ATUD20110	2.06 (0.19)
ATUD2020	2.32 (0.22)
ATUD2024	2.86 (0.27)
ATUD2028	3.39 (0.31)
ATUD2030	3.93 (0.37)
ATUD2118	1.91 (0.18)
ATUD2120	2.47 (0.23)
ATUD2124	3.03 (0.28)
ATUD2128	3.59 (0.33)
ATUD2130	4.15 (0.39)
ATUD2418	2.13 (0.20)
ATUD24110	2.45 (0.23)
ATUD2420	2.78 (0.26)
ATUD2424	3.42 (0.32)
ATUD2428	4.07 (0.38)
ATUD2430	4.71 (0.44)
ATUD2618	2.26 (0.21)
ATUD26110	2.61 (0.24)
ATUD2620	2.96 (0.27)
ATUD2624	3.66 (0.34)
ATUD2628	4.36 (0.41)
ATUD2630	5.06 (0.47)
ATUD2718	2.35 (0.22)
ATUD2720	3.08 (0.29)
ATUD2724	3.80 (0.35)
ATUD2728	4.53 (0.42)
ATUD2730	5.25 (0.49)
ATUD2818	2.42 (0.22)
ATUD28110	2.80 (0.26)
ATUD2820	3.18 (0.30)
ATUD2824	3.93 (0.37)
ATUD2828	4.69 (0.44)
ATUD2830	5.45 (0.51)
ATUD2918	2.47 (0.23)
ATUD2920	3.25 (0.30)
ATUD2924	4.03 (0.37)
ATUD2928	4.81 (0.45)
ATUD2930	5.59 (0.52)
ATUD2918G	2.48 (0.23)
ATUD2920G	3.27 (0.30)
ATUD2924G	4.06 (0.38)
ATUD2928G	4.84 (0.45)
ATUD2930G	5.63 (0.52)
ATUD21018	2.58 (0.24)
ATUD210110	2.98 (0.28)
ATUD21020	3.39 (0.31)
ATUD21024	4.20 (0.39)
ATUD21028	5.01 (0.47)
ATUD21030	5.83 (0.54)
ATUD3018	2.68 (0.25)
ATUD30110	3.11 (0.29)
ATUD3020	3.55 (0.33)
ATUD3024	4.42 (0.41)
ATUD3028	5.28 (0.49)
ATUD3030	6.15 (0.57)
ATUD3118	2.83 (0.26)

Window Number	Glass Area Sq. Ft./ (m <sup>2</sup> )
ATUD3120	3.72 (0.35)
ATUD3124	4.61 (0.43)
ATUD3128	5.50 (0.51)
ATUD3130	6.40 (0.59)
ATUD3218	2.88 (0.27)
ATUD32110	3.35 (0.31)
ATUD3220	3.81 (0.35)
ATUD3224	4.73 (0.44)
ATUD3228	5.66 (0.53)
ATUD3230	6.58 (0.61)
ATUD3318	2.93 (0.27)
ATUD3320	3.88 (0.36)
ATUD3324	4.82 (0.45)
ATUD3328	5.77 (0.54)
ATUD3330	6.72 (0.62)
ATUD3318G	2.94 (0.27)
ATUD3320G	3.89 (0.36)
ATUD3324G	4.85 (0.45)
ATUD3328G	5.80 (0.54)
ATUD3330G	6.76 (0.63)
ATUD3418	2.98 (0.28)
ATUD34110	3.47 (0.32)
ATUD3420	3.96 (0.37)
ATUD3424	4.94 (0.46)
ATUD3428	5.92 (0.55)
ATUD3430	6.90 (0.64)
ATUD3818	3.27 (0.30)
ATUD38110	3.81 (0.35)
ATUD3820	4.36 (0.41)
ATUD3824	5.45 (0.51)
ATUD3828	6.54 (0.61)
ATUAD3830	7.63 (0.71)
ATUAD3918	3.31 (0.31)
ATUAD3920	4.43 (0.41)
ATUAD3924	5.55 (0.52)
ATUAD3928	6.67 (0.62)
ATUAD3930	7.79 (0.72)
ATUAD40110	4.00 (0.37)
ATUAD4020	4.60 (0.43)
ATUAD4024	5.80 (0.54)
ATUAD4028	7.00 (0.65)
ATUAD4030	8.20 (0.76)
ATUAD4318	4.92 (0.46)
ATUAD4320	6.21 (0.58)
ATUAD4324	7.50 (0.70)
ATUAD4328	8.79 (0.82)
ATUAD44110	4.31 (0.40)
ATUAD4420	4.97 (0.46)
ATUAD4424	6.28 (0.58)
ATUAD4428	7.59 (0.71)
ATUAD4430	8.90 (0.83)
ATUAD48110	4.61 (0.43)
ATUAD4820	5.32 (0.49)
ATUAD4824	6.74 (0.63)
ATUAD4828	8.17 (0.76)
ATUAD4830	9.59 (0.89)
ATUAD5024	7.01 (0.65)
ATUAD5028	8.54 (0.79)
ATUAD5030	10.08 (0.94)

\* Dimensions in parentheses are in square meters.

continued on next page

**Direct-Set Unequal Leg Arch Window Area Specifications** *(continued)*

Window Number	Glass Area Sq. Ft./ (m <sup>2</sup> )	Window Number	Glass Area Sq. Ft./ (m <sup>2</sup> )	Window Number	Glass Area Sq. Ft./ (m <sup>2</sup> )	Window Number	Glass Area Sq. Ft./ (m <sup>2</sup> )
ATUAD5424	7.45 (0.69)	ATU2418	1.51 (0.14)	ATU21030	4.82 (0.45)	ATUA3828	5.43 (0.50)
ATUAD5428	9.09 (0.84)	ATU24110	1.80 (0.17)	ATU3018	1.93 (0.18)	ATUA3830	6.45 (0.60)
ATUAD5430	10.74 (1.00)	ATU2420	2.09 (0.19)	ATU30110	2.33 (0.22)	ATUA3918	2.41 (0.22)
ATUAD5824	7.87 (0.73)	ATU2424	2.66 (0.25)	ATU3020	2.73 (0.25)	ATUA3920	3.46 (0.32)
ATUAD5828	9.63 (0.89)	ATU2428	3.23 (0.30)	ATU3024	3.52 (0.33)	ATUA3924	4.50 (0.42)
ATUAD5830	11.38 (1.06)	ATU2430	3.80 (0.35)	ATU3028	4.32 (0.40)	ATUA3928	5.55 (0.52)
ATUAD6024	8.05 (0.75)	ATU2618	1.61 (0.15)	ATU3030	5.11 (0.47)	ATUA3930	6.60 (0.61)
ATUAD6028	9.91 (0.92)	ATU26110	1.92 (0.18)	ATU3118	2.06 (0.19)	ATUA40110	3.02 (0.28)
ATUAD6030	11.78 (1.09)	ATU2620	2.24 (0.21)	ATU3120	2.88 (0.27)	ATUA4020	3.58 (0.33)
		ATU2624	2.86 (0.27)	ATU3124	3.70 (0.34)	ATUA4024	4.71 (0.44)
		ATU2628	3.49 (0.32)	ATU3128	4.51 (0.42)	ATUA4028	5.84 (0.54)
		ATU2630	4.12 (0.38)	ATU3130	5.33 (0.50)	ATUA4030	6.96 (0.65)
		ATU2718	1.69 (0.16)	ATU3218	2.10 (0.20)	ATUA4318	3.85 (0.36)
		ATU2720	2.34 (0.22)	ATU32110	2.53 (0.24)	ATUA4320	5.06 (0.47)
		ATU2724	2.99 (0.28)	ATU3220	2.95 (0.27)	ATUA4324	6.28 (0.58)
		ATU2728	3.64 (0.34)	ATU3224	3.80 (0.35)	ATUA4328	7.49 (0.70)
		ATU2730	4.30 (0.40)	ATU3228	4.65 (0.43)	ATUA44110	3.26 (0.30)
		ATU2818	1.74 (0.16)	ATU3230	5.50 (0.51)	ATUA4420	3.88 (0.36)
		ATU28110	2.08 (0.19)	ATU3318	2.13 (0.20)	ATUA4424	5.12 (0.48)
		ATU2820	2.42 (0.22)	ATU3320	3.00 (0.28)	ATUA4428	6.36 (0.59)
		ATU2824	3.10 (0.29)	ATU3324	3.88 (0.36)	ATUA4430	7.60 (0.71)
		ATU2828	3.79 (0.35)	ATU3328	4.75 (0.44)	ATUA48110	3.49 (0.32)
		ATU2830	4.47 (0.42)	ATU3330	5.63 (0.52)	ATUA4820	4.17 (0.39)
		ATU2918	1.77 (0.16)	ATU3318G	2.14 (0.20)	ATUA4824	5.52 (0.51)
		ATU2920	2.48 (0.23)	ATU3320G	3.02 (0.28)	ATUA4828	6.87 (0.64)
		ATU2924	3.19 (0.30)	ATU3324G	3.90 (0.36)	ATUA4830	8.22 (0.76)
		ATU2928	3.89 (0.36)	ATU3328G	4.78 (0.44)	ATUA5024	5.72 (0.53)
		ATU2930	4.60 (0.43)	ATU3330G	5.66 (0.53)	ATUA5028	7.18 (0.67)
		ATU2918G	1.78 (0.17)	ATU3418	2.16 (0.20)	ATUA5030	8.64 (0.80)
		ATU2920G	2.50 (0.23)	ATU34110	2.62 (0.24)	ATUA5424	6.09 (0.57)
		ATU2924G	3.21 (0.30)	ATU3420	3.07 (0.29)	ATUA5428	7.66 (0.71)
		ATU2928G	3.92 (0.36)	ATU3424	3.98 (0.37)	ATUA5430	9.23 (0.86)
		ATU2930G	4.64 (0.43)	ATU3428	4.88 (0.45)	ATUA5824	6.45 (0.60)
		ATU21018	1.86 (0.17)	ATUA3430	5.79 (0.54)	ATUA5828	8.13 (0.76)
		ATU210110	2.23 (0.21)	ATUA3818	2.38 (0.22)	ATUA5830	9.81 (0.91)
		ATU21020	2.60 (0.24)	ATUA38110	2.89 (0.27)	ATUA6024	6.56 (0.61)
		ATU21024	3.34 (0.31)	ATUA3820	3.40 (0.32)	ATUA6028	8.36 (0.78)
		ATU21028	4.08 (0.38)	ATUA3824	4.42 (0.41)	ATUA6030	10.15 (0.94)

\* Dimensions in parentheses are in square meters.

**Sash-Set Half Circle Window Unobstructed Glass Dimensions and Area Specifications**

Window Number	Unobstructed Glass Width Inches/(mm)	Unobstructed Glass Height Inches/(mm)	Glass Area Sq. Ft./ (m <sup>2</sup> )
ATCT20	15 3/16" (386)	5" (127)	0.38 (0.04)
ATCT21	16 7/8" (410)	5 7/16" (138)	0.44 (0.04)
ATCT24	19 1/2" (495)	7" (178)	0.69 (0.06)
ATCT26	21 9/16" (548)	8" (203)	0.88 (0.08)
ATCT27	22 1/2" (572)	8 7/16" (214)	0.97 (0.09)
ATCT28	23 11/16" (602)	9" (229)	1.09 (0.10)
ATCT29	24 9/16" (624)	9 7/16" (240)	1.19 (0.11)
ATCT29G	24 13/16" (630)	9 9/16" (243)	1.22 (0.11)
ATCT210	25 1/8" (638)	10" (254)	1.32 (0.12)
ATCT30	27 13/16" (706)	11" (279)	1.57 (0.15)
ATCT31	28 11/16" (729)	11 7/16" (291)	1.69 (0.16)
ATCT32	29 7/8" (759)	12" (305)	1.85 (0.17)
ATCT33	30 3/4" (781)	12 7/16" (316)	1.98 (0.18)
ATCT33G	31" (787)	12 9/16" (319)	2.02 (0.19)
ATCT34	31 15/16" (811)	13" (330)	2.15 (0.20)

Window Number	Unobstructed Glass Width Inches/(mm)	Unobstructed Glass Height Inches/(mm)	Glass Area Sq. Ft./ (m <sup>2</sup> )
ATCT38	36" (914)	15" (381)	2.81 (0.26)
ATCT39	37 1/8" (943)	15 9/16" (395)	3.01 (0.28)
ATCT40	40 1/16" (1018)	17" (432)	3.56 (0.33)
ATCT43	43 3/16" (1097)	18 9/16" (471)	4.21 (0.39)
ATCT44	44 1/8" (1121)	19" (483)	4.40 (0.41)
ATCT48	48 1/8" (1222)	21" (533)	5.32 (0.49)
ATCT50	52 3/16" (1326)	23" (584)	6.33 (0.59)
ATCT54	56 3/16" (1427)	25" (635)	7.43 (0.69)
ATCT58	60 1/4" (1530)	27" (686)	8.62 (0.80)
ATCT60	64 1/4" (1632)	29" (737)	9.89 (0.92)
ATCT64	68 1/4" (1734)	31" (787)	11.25 (1.05)
ATCT68	72 3/16" (1837)	33" (838)	12.70 (1.18)
ATCT70	76 5/16" (1938)	35" (889)	14.23 (1.32)

**Sash-Set Elliptical Window Unobstructed Glass Dimensions and Area Specifications**

Window Number	Unobstructed Glass Width Inches/(mm)	Unobstructed Glass Height Inches/(mm)	Glass Area Sq. Ft./ (m <sup>2</sup> )
ATEI40	36 1/2" (927)	5 1/4" (133)	0.94 (0.09)
ATEI44	40 3/4" (1035)	6" (152)	1.18 (0.11)
ATEI48	46 7/16" (1180)	6 5/8" (168)	1.63 (0.15)
ATEI50	50 5/8" (1286)	7 3/8" (187)	1.84 (0.17)
ATEI54	55 1/2" (1410)	8 1/8" (206)	2.30 (0.21)
ATEI58	60 1/16" (1526)	8 7/8" (225)	2.78 (0.26)
ATEI60	63" (1600)	9 1/2" (241)	3.01 (0.28)
ATEI64	67 7/8" (1705)	10 1/4" (260)	3.48 (0.32)
ATEI68	71 7/8" (1826)	11" (279)	4.17 (0.39)
ATEI70	76 5/8" (1934)	11 3/4" (298)	4.74 (0.44)
ATEI74	79 3/8" (2016)	12 3/8" (314)	5.05 (0.47)
ATEI711	86 11/16" (2202)	13 3/4" (349)	6.20 (0.58)
ATEI80	87 1/2" (2223)	13 7/8" (352)	6.27 (0.58)
ATEI811	98 13/16" (2510)	15 7/8" (403)	8.18 (0.76)

\* Dimensions in parentheses are in millimeters or square meters.

### Sash-Set Quarter Circle Window Unobstructed Glass Dimensions and Area Specifications

Window Number	Unobstructed Glass Width Inches/(mm)	Unobstructed Glass Height Inches/(mm)	Glass Area Sq. Ft./ (m <sup>2</sup> )
ATQCT20	16 5/16" (414)	16 5/16" (414)	1.33 (0.12)
ATQCT21	17 3/16" (437)	17 3/16" (437)	1.48 (0.14)
ATQCT24	20 3/8" (518)	20 3/8" (518)	2.10 (0.20)
ATQCT26	22 3/8" (568)	22 3/8" (568)	2.55 (0.24)
ATQCT27	23 1/4" (591)	23 1/4" (591)	2.76 (0.26)
ATQCT28	24 3/8" (619)	24 3/8" (619)	3.04 (0.28)
ATQCT29	25 1/4" (641)	25 1/4" (641)	3.27 (0.30)
ATQCT29G	25 1/2" (648)	25 1/2" (648)	3.34 (0.31)
ATQCT210	26 7/16" (672)	26 7/16" (672)	3.58 (0.33)
ATQCT30	28 7/16" (722)	28 7/16" (722)	4.16 (0.39)
ATQCT31	29 5/16" (745)	29 5/16" (745)	4.43 (0.41)
ATQCT32	30 7/16" (773)	30 7/16" (773)	4.79 (0.45)
ATQCT33	31 5/16" (795)	31 5/16" (795)	5.08 (0.47)
ATQCT33G	31 9/16" (802)	31 9/16" (802)	5.16 (0.48)
ATQCT34	32 7/16" (824)	32 7/16" (824)	5.46 (0.51)
ATQCT36	34 7/16" (875)	34 7/16" (875)	6.17 (0.57)
ATQCT38	36 7/16" (926)	36 7/16" (926)	6.93 (0.64)
ATQCT39	37 9/16" (954)	37 9/16" (954)	7.37 (0.68)
ATQCT40	40 7/16" (1027)	40 7/16" (1027)	8.57 (0.80)
ATQCT43	43 5/8" (1108)	43 5/8" (1108)	9.98 (0.93)
ATQCT44	44 1/2" (1130)	44 1/2" (1130)	10.39 (0.97)
ATQCT48	48 1/2" (1232)	48 1/2" (1232)	12.38 (1.15)
ATQCT50	52 1/2" (1334)	52 1/2" (1334)	14.55 (1.35)
ATQCT54	56 1/2" (1435)	56 1/2" (1435)	16.89 (1.57)
ATQCT58	60 1/2" (1537)	60 1/2" (1537)	19.41 (1.80)
ATQCT60	64 1/2" (1638)	64 1/2" (1638)	22.10 (2.05)

### Sash-Set Octagon & Circle Window Unobstructed Glass Dimensions and Area Specifications

Window Number	Unobstructed Glass Width Inches/(mm)	Unobstructed Glass Height Inches/(mm)	Glass Area Sq. Ft./ (m <sup>2</sup> )
ATOC20	16 5/8" (422)	16 5/8" (422)	1.58 (0.15)
ATOC24	20 5/8" (524)	20 5/8" (524)	2.44 (0.23)
ATOC30	28 5/8" (727)	28 5/8" (727)	4.70 (0.44)
ATOC40	40 5/8" (1032)	40 5/8" (1032)	9.48 (0.88)
ATOC60	64 5/8" (1641)	64 5/8" (1641)	24.00 (2.23)
ACR20	16 5/8" (422)	16 5/8" (422)	1.50 (0.14)
ACR24	20 5/8" (524)	20 5/8" (524)	2.31 (0.21)
ACR30	28 5/8" (727)	28 5/8" (727)	4.46 (0.41)
ACR40	40 5/8" (1032)	40 5/8" (1032)	8.99 (0.84)
ACR60	64 5/8" (1641)	64 5/8" (1641)	22.76 (2.11)

\*Dimensions in parentheses are in millimeters or square meters.

### Custom Trapezoid Windows



Trapezoid windows are available in custom sizes in 1/8" (3) increments.

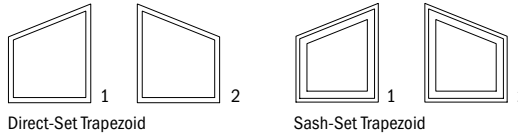

Available direct-set or sash-set. Choose left facing (1) or right facing (2) as viewed from the exterior.

### Design Criteria

Listed below are some factors that must be considered when deciding on a custom-size trapezoid window.

#### Minimum and Maximum Limits

Trapezoid windows may be assembled in custom sizes with these limitations:

**MAXIMUM FRAME AREA 50 sq. ft. or 4.65 m<sup>2</sup> for Low-E4<sup>®</sup> tempered impact-resistant glass**

**Square footage is based on a square or rectangular shape**

**For direct-set windows, no side may be less than 6" (152) and is dependent on slope**

**For sash-set windows, no side may be less than 8 1/2" (216) and is dependent on slope**

**Legs must be equal to or less than 60" (1524) on one side and equal to or less than 120" (3048) on the other side**

**Minimum cut angle is 12°**

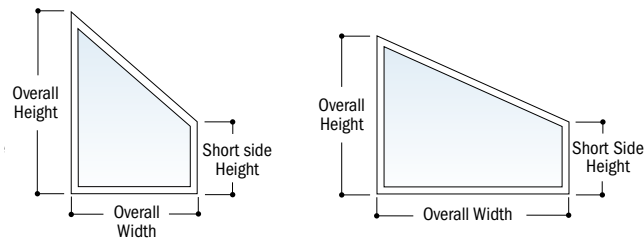

Specify overall width at sill, overall height and short side height. Slope is often designed to match a roof's pitch. Contact your Andersen supplier for more information.

Details shown on page 101.

Grille patterns are available in custom patterns. For more information on divided light, see page 15 or visit [andersenwindows.com/grilles](http://andersenwindows.com/grilles).

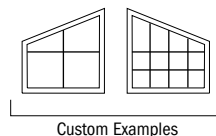

## Table of Direct-Set Arch Window Sizes

Scale 1/8" (3) = 1'-0" (305) – 1:96

Notes on page 79 also apply to this page.

Window Dimension	1'-11 1/4" (591)	2'-0 1/8" (613)	2'-3 1/4" (692)	2'-5 1/4" (743)	2'-6 1/8" (765)	2'-7 1/4" (794)	2'-8 1/8" (816)	2'-8 3/8" (822)	2'-9 1/4" (845)
<b>Minimum Rough Opening</b>	2'-0" (610)	2'-1" (635)	2'-4" (711)	2'-6" (762)	2'-7" (787)	2'-8" (813)	2'-9" (838)	2'-9" (838)	2'-10" (864)
Unobstructed Glass	19 1/4" (489)	20 1/8" (511)	23 1/4" (591)	25 1/4" (641)	26 1/8" (664)	27 1/4" (692)	28 1/8" (714)	28 3/8" (721)	29 1/4" (743)











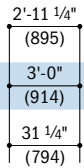
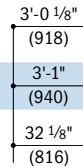
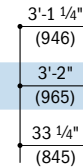
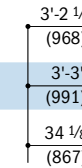
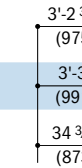
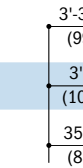
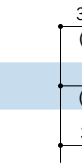
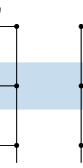
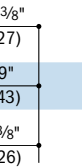
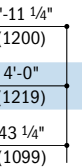
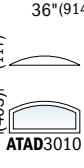

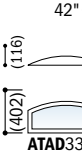
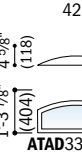
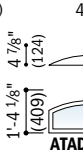
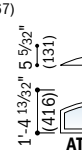
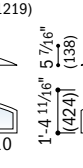





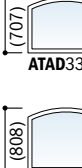

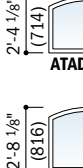

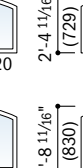
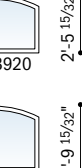



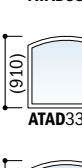



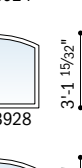

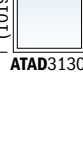



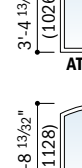

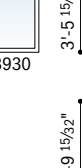





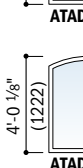

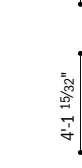



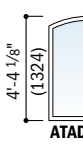
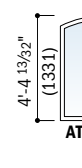
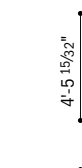

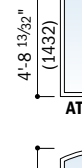
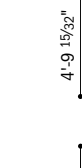

**Minimum Rough Opening = overall window height + 3/4" (19)**

Unobstructed Glass = window height - 4" (102)

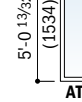
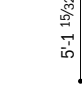
CUSTOM SIZES AVAILABLE												
Overall window height shown in table	Radius	Chord Height	Side Height	ATAD2010	ATAD2110	ATAD2410	ATAD2610	ATAD2710	ATAD2810	ATAD2910	ATAD2910G*	ATAD21010
11 1/4" (286)	24" (610)	3" (76)	11 1/4" (286)	1'-11 1/4" (591)	2'-0 1/8" (613)	2'-3 1/4" (692)	2'-5 1/4" (743)	2'-6 1/8" (765)	2'-7 1/4" (794)	2'-8 1/8" (816)	2'-8 3/8" (822)	2'-9 1/4" (845)
23 1/4" (591)	30" (762)	3 9/32" (83)	23 1/4" (591)	2'-0 1/8" (613)	2'-1" (635)	2'-4" (711)	2'-6" (762)	2'-7" (787)	2'-8" (813)	2'-9" (838)	2'-9" (838)	2'-10" (864)
27 1/4" (692)	30" (762)	3 13/16" (97)	27 1/4" (692)	2'-3 1/4" (692)	2'-5 1/4" (743)	2'-8 1/8" (816)	2'-10" (864)	2'-11 1/16" (897)	2'-12 1/16" (928)	2'-13 1/16" (959)	2'-13 1/16" (959)	2'-14 1/16" (990)
31 1/4" (794)	36" (914)	3 5/16" (84)	31 1/4" (794)	2'-6 1/8" (765)	2'-8 1/8" (816)	2'-11 1/16" (897)	2'-13 1/16" (959)	2'-14 1/16" (990)	2'-15 1/16" (1021)	2'-16 1/16" (1052)	2'-16 1/16" (1052)	2'-17 1/16" (1083)
35 1/4" (895)	36" (914)	3 9/16" (91)	35 1/4" (895)	2'-9 1/4" (845)	2'-11 1/4" (897)	2'-14 1/4" (959)	2'-16 1/4" (1021)	2'-17 1/4" (1052)	2'-18 1/4" (1083)	2'-19 1/4" (1114)	2'-19 1/4" (1114)	2'-20 1/4" (1145)
39 1/4" (997)	36" (914)	3 25/32" (96)	39 1/4" (997)	2'-12 1/4" (990)	2'-14 1/4" (1052)	2'-17 1/4" (1114)	2'-19 1/4" (1176)	2'-20 1/4" (1207)	2'-21 1/4" (1238)	2'-22 1/4" (1269)	2'-22 1/4" (1269)	2'-23 1/4" (1300)
43 1/4" (1099)	36" (914)	3 27/32" (98)	43 1/4" (1099)	2'-15 1/4" (1145)	2'-17 1/4" (1207)	2'-20 1/4" (1269)	2'-22 1/4" (1331)	2'-23 1/4" (1362)	2'-24 1/4" (1393)	2'-25 1/4" (1424)	2'-25 1/4" (1424)	2'-26 1/4" (1455)
47 1/4" (1200)	36" (914)	4 1/16" (103)	47 1/4" (1200)	2'-18 1/4" (1300)	2'-20 1/4" (1362)	2'-23 1/4" (1424)	2'-25 1/4" (1486)	2'-26 1/4" (1517)	2'-27 1/4" (1548)	2'-28 1/4" (1579)	2'-28 1/4" (1579)	2'-29 1/4" (1610)
51 1/4" (1302)	36" (914)	4 1/16" (103)	51 1/4" (1302)	2'-21 1/4" (1403)	2'-23 1/4" (1465)	2'-26 1/4" (1527)	2'-28 1/4" (1589)	2'-29 1/4" (1620)	2'-30 1/4" (1651)	2'-31 1/4" (1682)	2'-31 1/4" (1682)	2'-32 1/4" (1713)
55 1/4" (1403)	36" (914)	4 1/16" (103)	55 1/4" (1403)	2'-24 1/4" (1504)	2'-26 1/4" (1566)	2'-29 1/4" (1628)	2'-31 1/4" (1690)	2'-32 1/4" (1721)	2'-33 1/4" (1752)	2'-34 1/4" (1783)	2'-34 1/4" (1783)	2'-35 1/4" (1814)

\*"Window Dimension" always refers to outside frame to frame dimension.  
 \*"**Minimum Rough Opening**" dimensions may need to be increased to allow for use of building wraps, flashing, sill panning, brackets, fasteners or other items. See installation information on page 170.  
 • Dimensions in parentheses are in millimeters.  
 \*Sized to fit over single-panel, stationary A-Series Frenchwood® gliding patio doors.

Notes on page 79 also apply to this page. Arch sizes on pages 76-88.

 2'-11 1/4" (895) 3'-0" (914) 31 1/4" (794)	 3'-0 1/8" (918) 3'-1" (940) 32 1/8" (816)	 3'-1 1/4" (946) 3'-2" (965) 33 1/4" (845)	 3'-2 1/8" (968) 3'-3" (991) 34 1/8" (867)	 3'-2 3/8" (975) 3'-3" (991) 34 3/8" (873)	 3'-3 1/4" (997) 3'-4" (1016) 35 1/4" (895)	 3'-7 1/4" (1099) 3'-8" (1118) 39 1/4" (997)	 3'-8 3/8" (1127) 3'-9" (1143) 40 3/8" (1026)	 3'-11 1/4" (1200) 4'-0" (1219) 43 1/4" (1099)	 4'-2 3/8" (1280) 4'-3" (1295) 46 3/8" (1178)
 36" (914) 4 5/8" (117) 1'-3 7/8" (403) ATAD3010	 36" (914) 4 27/32" (123) 1'-4 3/32" (409) ATAD3110	 42" (1067) 4 11/32" (111) 1'-3 19/32" (396) ATAD3210	 42" (1067) 4 9/16" (116) 1'-3 13/16" (402) ATAD3310	 42" (1067) 4 5/8" (118) 1'-3 7/8" (404) ATAD3310G*	 42" (1067) 4 7/8" (124) 1'-4 1/8" (409) ATAD3410	 48" (1219) 5 5/32" (131) 1'-4 13/32" (416) ATAD3810	 48" (1219) 5 7/16" (138) 1'-4 11/16" (424) ATAD3910	 48" (1219) 6 7/8" (168) 1'-5 15/32" (444) ATAD4010	 60" (1524) 5 17/32" (141) 1'-4 25/32" (427) ATAD4310
 2'-3 7/8" (708) ATAD3020	 2'-4 3/8" (714) ATAD3120	 2'-3 19/32" (701) ATAD3220	 2'-3 13/16" (707) ATAD3320	 2'-3 7/8" (708) ATAD3320G*	 2'-4 1/8" (714) ATAD3420	 2'-4 13/32" (721) ATAD3820	 2'-4 11/16" (729) ATAD3920	 2'-5 15/32" (748) ATAD4020	 2'-4 25/32" (731) ATAD4320
 2'-7 7/8" (809) ATAD3024	 2'-8 3/32" (816) ATAD3124	 2'-7 19/32" (803) ATAD3224	 2'-7 13/16" (808) ATAD3324	 2'-7 7/8" (810) ATAD3324G*	 2'-8 1/8" (816) ATAD3424	 2'-8 13/32" (823) ATAD3824	 2'-8 11/16" (830) ATAD3924	 2'-9 15/32" (850) ATAD4024	 2'-8 25/32" (833) ATAD4324
 2'-11 7/8" (911) ATAD3028	 3'-0 3/32" (917) ATAD3128	 2'-11 19/32" (904) ATAD3228	 2'-11 13/16" (910) ATAD3328	 2'-11 7/8" (912) ATAD3328G*	 3'-0 1/8" (917) ATAD3428	 3'-0 13/32" (924) ATAD3828	 3'-0 11/16" (932) ATAD3928	 3'-1 15/32" (952) ATAD4028	 3'-0 25/32" (935) ATAD4328
 3'-3 7/8" (1012) ATAD3030	 3'-4 3/32" (1019) ATAD3130	 3'-3 19/32" (1006) ATAD3230	 3'-3 13/16" (1012) ATAD3330	 3'-3 7/8" (1013) ATAD3330G*	 3'-4 1/8" (1019) ATAD3430	 3'-4 13/32" (1026) ATAD3830	 3'-4 11/16" (1033) ATAD3930	 3'-5 15/32" (1053) ATAD4030	 3'-4 25/32" (1036) ATAD4330
 3'-7 7/8" (1114) ATAD3034	 3'-7 19/32" (1108) ATAD3234	 3'-8 1/8" (1121) ATAD3434	 3'-8 13/32" (1128) ATAD3834	 3'-9 15/32" (1155) ATAD4034					
 3'-11 7/8" (1216) ATAD3038	 3'-11 19/32" (1209) ATAD3238	 4'-0 1/8" (1222) ATAD3438	 4'-0 13/32" (1229) ATAD3838	 4'-1 15/32" (1256) ATAD4038					
 4'-3 7/8" (1317) ATAD3040	 4'-3 19/32" (1311) ATAD3240	 4'-4 1/8" (1324) ATAD3440	 4'-4 13/32" (1331) ATAD3840	 4'-5 15/32" (1358) ATAD4040					
 4'-7 7/8" (1419) ATAD3044	 4'-7 19/32" (1412) ATAD3244	 4'-8 1/8" (1425) ATAD3444	 4'-8 13/32" (1432) ATAD3844	 4'-9 15/32" (1460) ATAD4044					
 4'-11 7/8" (1520) ATAD3048	 4'-11 19/32" (1514) ATAD3248	 5'-0 1/8" (1527) ATAD3448	 5'-0 13/32" (1534) ATAD3848	 5'-1 15/32" (1561) ATAD4048					

continued on next page

\*Window Dimension\* always refers to outside frame to frame dimension.  
**\*\*Minimum Rough Opening\* dimensions may need to be increased to allow for use of building wraps, flashing, sill panning, brackets, fasteners or other items. See installation information on page 170.**  
 • Dimensions in parentheses are in millimeters.  
 \*Sized to fit over single-panel, stationary A-Series Frenchwood® gliding patio doors.

**Table of Direct-Set Arch Window Sizes** (continued)

Scale 1/8" (3) = 1'-0" (305) – 1:96

Notes on the next page also apply to this page.

Window Dimension	1'-11 1/4" (591)	2'-0 1/8" (613)	2'-3 1/4" (692)	2'-5 1/4" (743)	2'-6 1/8" (765)	2'-7 1/4" (794)	2'-8 1/8" (816)	2'-8 3/8" (822)	2'-9 1/4" (845)
<b>Minimum Rough Opening</b>	2'-0" (610)	2'-1" (635)	2'-4" (711)	2'-6" (762)	2'-7" (787)	2'-8" (813)	2'-9" (838)	2'-9" (838)	2'-10" (864)
Unobstructed Glass	19 1/4" (489)	20 1/8" (511)	23 1/4" (591)	25 1/4" (641)	26 1/8" (664)	27 1/4" (692)	28 1/8" (714)	28 3/8" (721)	29 1/4" (743)

**CUSTOM SIZES AVAILABLE**

**Minimum Rough Opening = overall window height + 3/4" (19)**

Unobstructed Glass = window height - 4" (102)

**CUSTOM SIZES AVAILABLE**

Radius	24" (610)	30" (762)	30" (762)	36" (914)	36" (914)
Chord Height	3" (76)	3 9/32" (88)	3 13/16" (97)	3 9/16" (91)	4 1/16" (103)
Side Height	59 1/4" (1505) 5'-2 1/4" (1581)	5'-2 17/32" (1588)	5'-3 1/16" (1602)	5'-2 13/16" (1596)	5'-3 5/16" (1608)
ATAD	ATAD2050	ATAD2450	ATAD2650	ATAD2850	ATAD21050
Side Height	63 1/4" (1607) 5'-6 1/4" (1683)	5'-6 17/32" (1690)	5'-7 1/16" (1703)	5'-6 13/16" (1697)	5'-7 5/16" (1710)
ATAD	ATAD2054	ATAD2454	ATAD2654	ATAD2854	ATAD21054*
Side Height	67 1/4" (1708) 5'-10 1/4" (1784)	5'-10 17/32" (1791)	5'-11 1/16" (1805)	5'-10 13/16" (1799)	5'-11 5/16" (1811)
ATAD	ATAD2058	ATAD2458	ATAD2658	ATAD2858*	ATAD21058*
Side Height	71 1/4" (1810) 6'-2 1/4" (1886)	6'-2 17/32" (1893)	6'-3 1/16" (1906)	6'-2 13/16" (1900)	6'-3 5/16" (1913)
ATAD	ATAD2060	ATAD2460	ATAD2660*	ATAD2860*	ATAD21060*
Side Height	75 1/4" (1911) 6'-6 1/4" (1988)	6'-6 17/32" (1994)	6'-7 1/16" (2008)	6'-6 13/16" (2002)	6'-7 5/16" (2015)
ATAD	ATAD2064	ATAD2464	ATAD2664*	ATAD2864*	ATAD21064*
Side Height	79 1/4" (2013) 6'-10 1/4" (2089)	6'-10 17/32" (2096)	6'-11 1/16" (2110)	6'-10 13/16" (2104)	6'-11 5/16" (2116)
ATAD	ATAD2068	ATAD2468*	ATAD2668*	ATAD2868*	ATAD21068*
Side Height	87 1/4" (2216) 7'-6 1/4" (2292)	7'-6 17/32" (2299)	7'-7 1/16" (2313)	7'-6 13/16" (2307)	7'-7 5/16" (2319)
ATAD	ATAD2074	ATAD2474*	ATAD2674*	ATAD2874*	ATAD21074*

\*"Window Dimension" always refers to outside frame to frame dimension.  
 \*"**Minimum Rough Opening**" dimensions may need to be increased to allow for use of building wraps, flashing, sill panning, brackets, fasteners or other items. See installation information on page 170.  
 • Dimensions in parentheses are in millimeters.  
 \*Tempered laminated glass required. Some visual distortion may occur.



Arch sizes on pages 76-88.

2'-11 1/4" (895)	3'-0 1/8" (918)	3'-1 1/4" (946)	3'-2 1/8" (968)	3'-2 3/8" (975)	3'-3 1/4" (997)	3'-7 1/4" (1099)	3'-8 3/8" (1127)	3'-11 1/4" (1200)	4'-2 3/8" (1280)
3'-0" (914)	3'-1" (940)	3'-2" (965)	3'-3" (991)	3'-3" (991)	3'-4" (1016)	3'-8" (1118)	3'-9" (1143)	4'-0" (1219)	4'-3" (1295)
31 1/4" (794)	32 1/8" (816)	33 1/4" (845)	34 1/8" (867)	34 3/8" (873)	35 1/4" (895)	39 1/4" (997)	40 3/8" (1026)	43 1/4" (1099)	46 3/8" (1178)

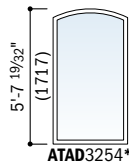
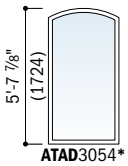
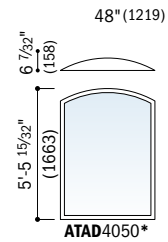
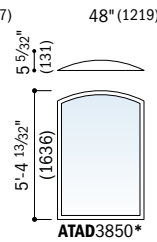
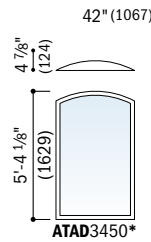
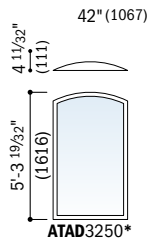
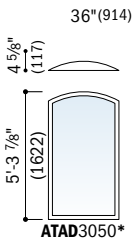

Custom-size windows are available in 1/8" (3) increments. Contact your Andersen supplier for more information.

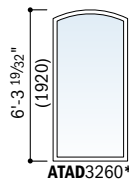
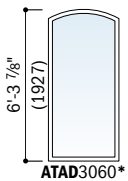
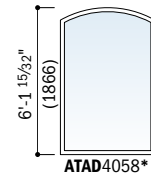
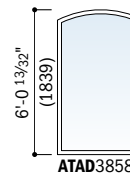
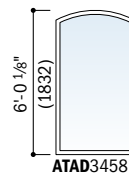
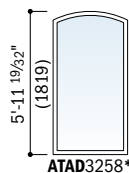
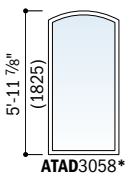
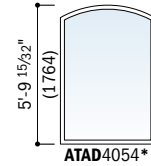
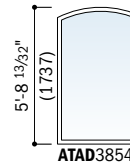
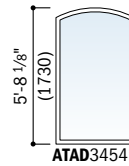

**Direct-set (ATAD) window sizes shown.** Use window dimensions and minimum rough opening formula shown for sash-set (ATA) window sizes. For sash-set unobstructed glass dimensions, see page 86.

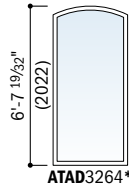
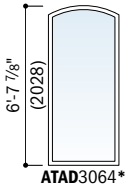
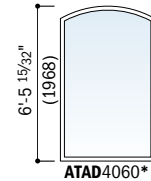
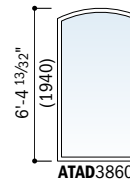
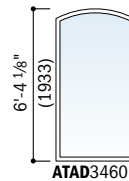

Details shown on page 101. Grille patterns shown on page 97.

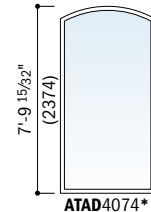
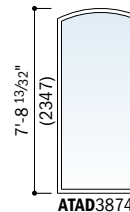
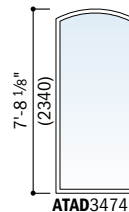
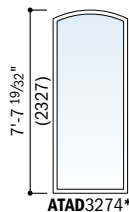
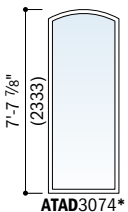
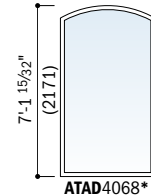
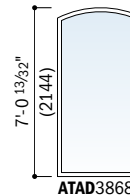
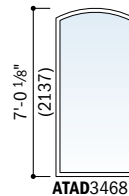
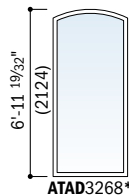
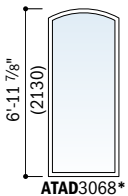
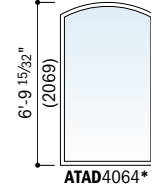
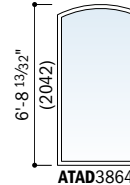
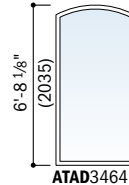

\*"Window Dimension" always refers to outside frame to frame dimension.  
 • "Minimum Rough Opening" dimensions may need to be increased to allow for use of building wraps, flashing, sill panning, brackets, fasteners or other items. See installation information on page 170.  
 • Dimensions in parentheses are in millimeters.  
 • Tempered laminated glass required. Some visual distortion may occur.

continued on next page

**Table of Direct-Set Arch Window Sizes** (continued)

Notes on the next page also apply to this page.

Scale 1/8" (3) = 1'-0" (305) – 1:96

Window Dimension	1'-11 1/4" (591)	2'-0 1/8" (613)	2'-3 1/4" (692)	2'-5 1/4" (743)	2'-6 1/8" (765)	2'-7 1/4" (794)	2'-8 1/8" (816)	2'-8 3/8" (822)	2'-9 1/4" (845)
<b>Minimum Rough Opening</b>	2'-0" (610)	2'-1" (635)	2'-4" (711)	2'-6" (762)	2'-7" (787)	2'-8" (813)	2'-9" (838)	2'-9" (838)	2'-10" (864)
Unobstructed Glass	19 1/4" (489)	20 1/8" (511)	23 1/4" (591)	25 1/4" (641)	26 1/8" (664)	27 1/4" (692)	28 1/8" (714)	28 3/8" (721)	29 1/4" (743)

**CUSTOM SIZES AVAILABLE**

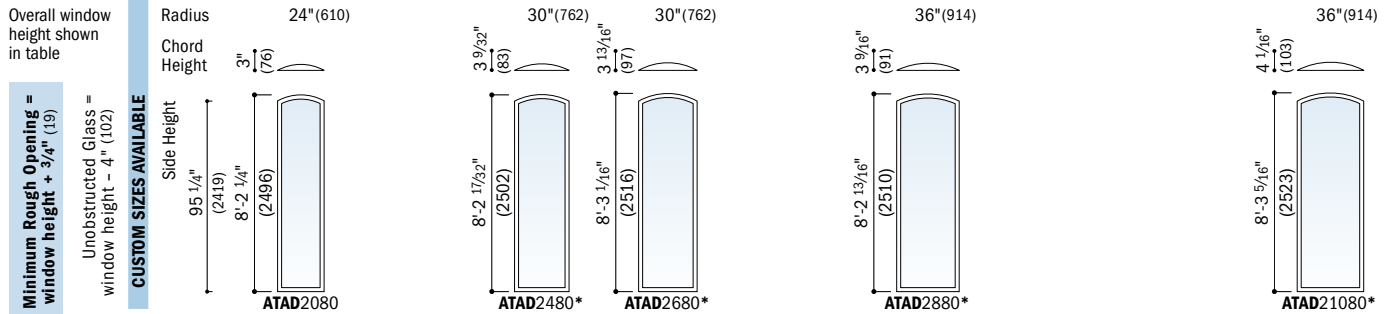

**Direct-Set Arch Window Area Specifications**

Window Number	Glass Area Sq. Ft./ (m <sup>2</sup> )	Window Number	Glass Area Sq. Ft./ (m <sup>2</sup> )	Window Number	Glass Area Sq. Ft./ (m <sup>2</sup> )	Window Number	Glass Area Sq. Ft./ (m <sup>2</sup> )
ATAD2010	1.27 (0.12)	ATAD2464	11.90 (1.11)	ATAD2850	10.95 (1.02)	ATAD3020	4.91 (0.46)
ATAD2020	2.88 (0.27)	ATAD2468	12.54 (1.17)	ATAD2854	11.71 (1.09)	ATAD3024	5.78 (0.54)
ATAD2024	3.41 (0.32)	ATAD2474	13.84 (1.29)	ATAD2858	12.47 (1.16)	ATAD3028	6.65 (0.62)
ATAD2028	3.95 (0.37)	ATAD2480	15.13 (1.41)	ATAD2860	13.22 (1.23)	ATAD3030	7.51 (0.70)
ATAD2030	4.48 (0.42)	ATAD2610	1.77 (0.16)	ATAD2864	13.98 (1.30)	ATAD3034	8.38 (0.78)
ATAD2034	5.02 (0.47)	ATAD2620	3.87 (0.36)	ATAD2868	14.74 (1.37)	ATAD3038	9.25 (0.86)
ATAD2038	5.55 (0.52)	ATAD2624	4.57 (0.42)	ATAD2874	16.25 (1.51)	ATAD3040	10.12 (0.94)
ATAD2040	6.09 (0.57)	ATAD2628	5.27 (0.49)	ATAD2880	17.77 (1.65)	ATAD3044	10.99 (1.02)
ATAD2044	6.62 (0.62)	ATAD2630	5.98 (0.56)	ATAD2910	1.96 (0.18)	ATAD3048	11.85 (1.10)
ATAD2048	7.16 (0.67)	ATAD2634	6.68 (0.62)	ATAD2920	4.30 (0.40)	ATAD3050	12.72 (1.18)
ATAD2050	7.69 (0.71)	ATAD2638	7.38 (0.69)	ATAD2924	5.09 (0.47)	ATAD3054	13.59 (1.26)
ATAD2054	8.23 (0.76)	ATAD2640	8.08 (0.75)	ATAD2928	5.87 (0.55)	ATAD3058	14.46 (1.34)
ATAD2058	8.76 (0.81)	ATAD2644	8.78 (0.82)	ATAD2930	6.65 (0.62)	ATAD3060	15.33 (1.42)
ATAD2060	9.29 (0.86)	ATAD2648	9.48 (0.88)	ATAD2910G	1.99 (0.18)	ATAD3064	16.19 (1.50)
ATAD2064	9.83 (0.91)	ATAD2650	10.18 (0.95)	ATAD2920G	4.35 (0.40)	ATAD3068	17.06 (1.58)
ATAD2068	10.36 (0.96)	ATAD2654	10.88 (1.01)	ATAD2924G	5.14 (0.48)	ATAD3074	18.80 (1.75)
ATAD2074	11.43 (1.06)	ATAD2658	11.59 (1.08)	ATAD2928G	5.93 (0.55)	ATAD3080	20.53 (1.91)
ATAD2080	12.50 (1.16)	ATAD2660	12.29 (1.14)	ATAD2930G	6.72 (0.62)	ATAD3110	2.41 (0.22)
ATAD2110	1.28 (0.12)	ATAD2664	12.99 (1.21)	ATAD21010	2.08 (0.19)	ATAD3120	5.09 (0.47)
ATAD2120	2.96 (0.27)	ATAD2668	13.69 (1.27)	ATAD21020	4.52 (0.42)	ATAD3124	5.98 (0.56)
ATAD2124	3.52 (0.33)	ATAD2674	15.09 (1.40)	ATAD21024	5.33 (0.50)	ATAD3128	6.87 (0.64)
ATAD2128	4.08 (0.38)	ATAD2680	16.50 (1.53)	ATAD21028	6.14 (0.57)	ATAD3130	7.76 (0.72)
ATAD2130	4.64 (0.43)	ATAD2710	1.76 (0.16)	ATAD21030	6.95 (0.65)	ATAD3210	2.41 (0.22)
ATAD2410	1.57 (0.15)	ATAD2720	3.94 (0.37)	ATAD21034	7.77 (0.72)	ATAD3220	5.18 (0.48)
ATAD2420	3.50 (0.33)	ATAD2724	4.66 (0.43)	ATAD21038	8.58 (0.80)	ATAD3224	6.10 (0.57)
ATAD2424	4.15 (0.39)	ATAD2728	5.39 (0.50)	ATAD21040	9.39 (0.87)	ATAD3228	7.02 (0.65)
ATAD2428	4.79 (0.45)	ATAD2730	6.11 (0.57)	ATAD21044	10.20 (0.95)	ATAD3230	7.95 (0.74)
ATAD2430	5.44 (0.51)	ATAD2810	1.87 (0.17)	ATAD21048	11.02 (1.02)	ATAD3234	8.87 (0.82)
ATAD2434	6.09 (0.57)	ATAD2820	4.14 (0.38)	ATAD21050	11.83 (1.10)	ATAD3238	9.80 (0.91)
ATAD2438	6.73 (0.63)	ATAD2824	4.90 (0.46)	ATAD21054	12.64 (1.17)	ATAD3240	10.72 (1.00)
ATAD2440	7.38 (0.69)	ATAD2828	5.66 (0.53)	ATAD21058	13.45 (1.25)	ATAD3244	11.64 (1.08)
ATAD2444	8.02 (0.75)	ATAD2830	6.41 (0.60)	ATAD21060	14.27 (1.33)	ATAD3248	12.57 (1.17)
ATAD2448	8.67 (0.81)	ATAD2834	7.17 (0.67)	ATAD21064	15.08 (1.40)	ATAD3250	13.49 (1.25)
ATAD2450	9.32 (0.87)	ATAD2838	7.93 (0.74)	ATAD21068	15.89 (1.48)	ATAD3254	14.41 (1.34)
ATAD2454	9.96 (0.93)	ATAD2840	8.68 (0.81)	ATAD21074	17.52 (1.63)	ATAD3258	15.34 (1.43)
ATAD2458	10.61 (0.99)	ATAD2844	9.44 (0.88)	ATAD21080	19.14 (1.78)	ATAD3260	16.26 (1.51)
ATAD2460	11.25 (1.05)	ATAD2848	10.20 (0.95)	ATAD3010	2.31 (0.21)		

\*Dimensions in parentheses are in square meters.

continued on next page

Arch sizes on pages 76-88.

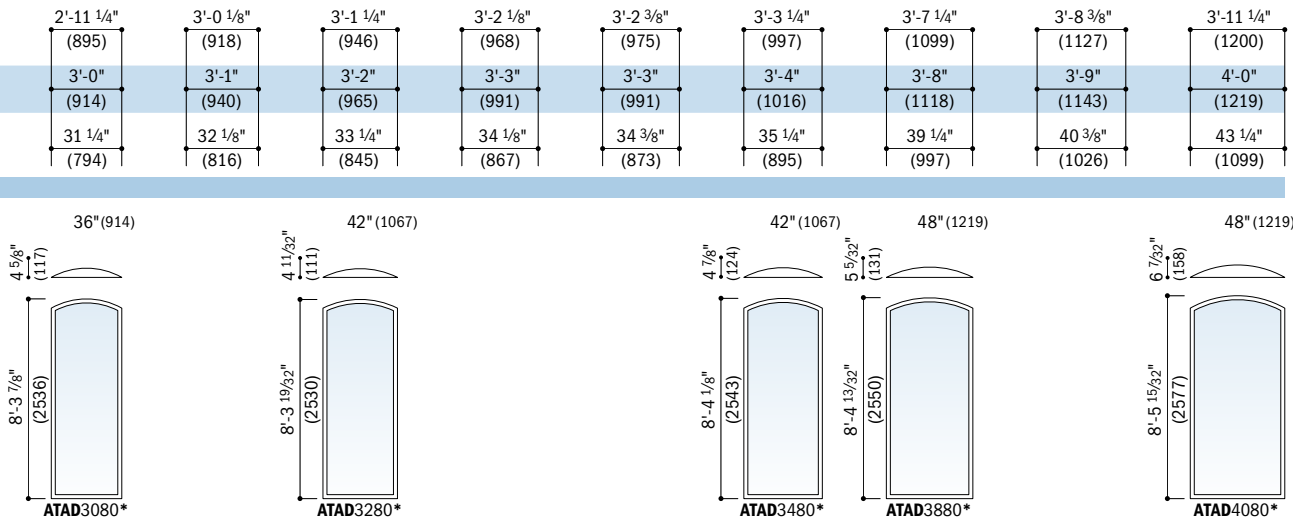

continued on next page

**Direct-Set Arch Window Area Specifications** (continued)

Window Number	Glass Area Sq. Ft./ (m <sup>2</sup> )	Window Number	Glass Area Sq. Ft./ (m <sup>2</sup> )	Window Number	Glass Area Sq. Ft./ (m <sup>2</sup> )
ATAD3264	17.18 (1.60)	ATAD3834	10.62 (0.99)	ATAD4320	7.47 (0.69)
ATAD3268	18.11 (1.68)	ATAD3838	11.71 (1.09)	ATAD4324	8.76 (0.81)
ATAD3274	19.95 (1.85)	ATAD3840	12.80 (1.19)	ATAD4328	10.05 (0.93)
ATAD3280	21.80 (2.03)	ATAD3844	13.89 (1.29)	ATAD4330	11.34 (1.05)
ATAD3310	2.51 (0.23)	ATAD3848	14.98 (1.39)	ATAD4410	3.72 (0.35)
ATAD3320	5.35 (0.50)	ATAD3850	16.07 (1.49)	ATAD4420	7.66 (0.71)
ATAD3324	6.30 (0.59)	ATAD3854	17.16 (1.59)	ATAD4424	8.97 (0.83)
ATAD3328	7.25 (0.67)	ATAD3858	18.25 (1.70)	ATAD4428	10.29 (0.96)
ATAD3330	8.19 (0.76)	ATAD3860	19.34 (1.80)	ATAD4430	11.60 (1.08)
ATAD3310G	2.54 (0.24)	ATAD3864	20.43 (1.90)	ATAD4434	12.91 (1.20)
ATAD3320G	5.40 (0.50)	ATAD3868	21.52 (2.00)	ATAD4438	14.22 (1.32)
ATAD3324G	6.35 (0.59)	ATAD3874	23.70 (2.20)	ATAD4440	15.54 (1.44)
ATAD3328G	7.31 (0.68)	ATAD3880	25.88 (2.40)	ATAD4444	16.85 (1.57)
ATAD3330G	8.26 (0.77)	ATAD3910	3.13 (0.29)	ATAD4448	18.16 (1.69)
ATAD3410	2.64 (0.25)	ATAD3920	6.49 (0.60)	ATAD4450	19.47 (1.81)
ATAD3420	5.58 (0.52)	ATAD3924	7.62 (0.71)	ATAD4454	20.79 (1.93)
ATAD3424	6.56 (0.61)	ATAD3928	8.74 (0.81)	ATAD4458	22.10 (2.05)
ATAD3428	7.54 (0.70)	ATAD3930	9.86 (0.92)	ATAD4460	23.41 (2.17)
ATAD3430	8.51 (0.79)	ATAD4010	3.52 (0.33)	ATAD4464	24.72 (2.30)
ATAD3434	9.49 (0.88)	ATAD4020	7.12 (0.66)	ATAD4468	26.04 (2.42)
ATAD3438	10.47 (0.97)	ATAD4024	8.32 (0.77)	ATAD4474	28.66 (2.66)
ATAD3440	11.45 (1.06)	ATAD4028	9.52 (0.88)	ATAD4480	31.29 (2.91)
ATAD3444	12.43 (1.15)	ATAD4030	10.73 (1.00)	ATAD4810	4.29 (0.40)
ATAD3448	13.41 (1.25)	ATAD4034	11.93 (1.11)	ATAD4820	8.56 (0.80)
ATAD3450	14.39 (1.34)	ATAD4038	13.13 (1.22)	ATAD4824	9.98 (0.93)
ATAD3454	15.37 (1.43)	ATAD4040	14.33 (1.33)	ATAD4828	11.40 (1.06)
ATAD3458	16.35 (1.52)	ATAD4044	15.53 (1.44)	ATAD4830	12.83 (1.19)
ATAD3460	17.33 (1.61)	ATAD4048	16.73 (1.55)	ATAD4834	14.25 (1.32)
ATAD3464	18.31 (1.70)	ATAD4050	17.93 (1.67)	ATAD4838	15.67 (1.46)
ATAD3468	19.29 (1.79)	ATAD4054	19.14 (1.78)	ATAD4840	17.10 (1.59)
ATAD3474	21.24 (1.97)	ATAD4058	20.34 (1.89)	ATAD4844	18.52 (1.72)
ATAD3480	23.20 (2.16)	ATAD4060	21.54 (2.00)	ATAD4848	19.95 (1.85)
ATAD3810	2.99 (0.28)	ATAD4064	22.74 (2.11)	ATAD4850	21.37 (1.99)
ATAD3820	6.26 (0.58)	ATAD4068	23.94 (2.22)	ATAD4854	22.79 (2.12)
ATAD3824	7.35 (0.68)	ATAD4074	26.34 (2.45)	ATAD4858	24.22 (2.25)
ATAD3828	8.44 (0.78)	ATAD4080	28.75 (2.67)	ATAD4860	25.64 (2.38)
ATAD3830	9.53 (0.89)	ATAD4310	3.61 (0.34)		

\*Dimensions in parentheses are in square meters.

continued on page 85



Custom-size windows are available in 1/8" (3) increments. Contact your Andersen supplier for more information.

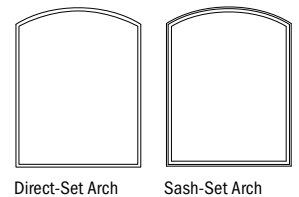

**Direct-set (ATAD) window sizes shown.** Use window dimensions and minimum rough opening formula shown for sash-set (ATA) window sizes. For sash-set unobstructed glass dimensions, see page 86.

Details shown on page 101.

Grille patterns shown on page 97.

- \* "Window Dimension" always refers to outside frame to frame dimension.
- \*\* "Minimum Rough Opening" dimensions may need to be increased to allow for use of building wraps, flashing, sill panning, brackets, fasteners or other items. See installation information on page 170.
- Dimensions in parentheses are in millimeters.
- \*Tempered laminated glass required. Some visual distortion may occur.

**Table of Direct-Set Arch Window Sizes** (continued)

Scale 1/8" (3) = 1'-0" (305) – 1:96

Notes on page 85 also apply to this page.

Window Dimension	4'-3 1/4" (1302)	4'-7 1/4" (1403)	4'-11 1/4" (1505)	5'-3 1/4" (1607)	5'-7 1/4" (1708)	5'-11 1/4" (1810)
<b>Minimum Rough Opening</b>	4'-4" (1321)	4'-8" (1422)	5'-0" (1524)	5'-4" (1626)	5'-8" (1727)	6'-0" (1829)
Unobstructed Glass	47 1/4" (1200)	51 1/4" (1302)	55 1/4" (1403)	59 1/4" (1505)	63 1/4" (1607)	67 1/4" (1708)

**CUSTOM SIZES AVAILABLE**

Minimum Rough Opening = overall window height + 3/4" (19)

Unobstructed Glass = window height - 4" (102)

CUSTOM SIZES AVAILABLE

Overall window height shown in table	Radius	60" (1524)	60" (1524)	60" (1524)	72" (1829)	72" (1829)	72" (1829)
Chord Height		5 3/4" (146)	6 3/4" (171)	7 13/16" (199)	7 9/16" (186)	8 11/32" (212)	9 7/16" (240)
Side Height		11 1/4" (286)	1'-6" (457)	1'-7 1/16" (484)	1'-6 9/16" (472)	1'-7 19/32" (497)	1'-8 11/16" (525)
		23 1/4" (591)	2'-6" (762)	2'-7 1/16" (789)	2'-6 9/16" (776)	2'-7 19/32" (802)	2'-8 11/16" (830)
		27 1/4" (692)	2'-10" (863)	2'-11 1/16" (891)	2'-10 9/16" (878)	2'-11 19/32" (904)	3'-0 11/16" (932)
		31 1/4" (794)	3'-2" (965)	3'-3 1/16" (992)	3'-2 9/16" (980)	3'-3 19/32" (1005)	3'-4 11/16" (1033)
		35 1/4" (895)	3'-6" (1066)	3'-7 1/16" (1094)	3'-6 9/16" (1081)	3'-7 19/32" (1107)	3'-8 11/16" (1135)
		39 1/4" (997)	3'-10" (1168)	3'-11 1/16" (1196)	3'-10 9/16" (1183)	3'-11 19/32" (1209)	4'-0 11/16" (1237)
		43 1/4" (1099)	4'-2" (1270)	4'-3 1/16" (1297)	4'-2 9/16" (1284)	4'-3 19/32" (1310)	4'-4 11/16" (1338)
		47 1/4" (1200)	4'-6" (1371)	4'-7 1/16" (1399)	4'-6 9/16" (1386)	4'-7 19/32" (1412)	4'-8 11/16" (1440)
		51 1/4" (1302)	4'-10" (1473)	4'-11 1/16" (1500)	4'-10 9/16" (1488)	4'-11 19/32" (1513)	5'-0 11/16" (1541)
		55 1/4" (1403)	5'-2" (1574)	5'-3 1/16" (1602)	5'-2 9/16" (1589)	5'-3 19/32" (1615)	5'-4 11/16" (1643)
		ATAD4410	ATAD4810	ATAD5010	ATAD5410	ATAD5810	ATAD6010
		ATAD4420	ATAD4820	ATAD5020	ATAD5420	ATAD5820	ATAD6020*
		ATAD4424	ATAD4824	ATAD5024	ATAD5424*	ATAD5824*	ATAD6024*
		ATAD4428	ATAD4828	ATAD5028*	ATAD5428*	ATAD5828*	ATAD6028*
		ATAD4430	ATAD4830*	ATAD5030*	ATAD5430*	ATAD5830*	ATAD6030*
		ATAD4434*	ATAD4834*	ATAD5034*	ATAD5434*	ATAD5834*	ATAD6034*
		ATAD4438*	ATAD4838*	ATAD5038*	ATAD5438*	ATAD5838*	ATAD6038*
		ATAD4440*	ATAD4840*	ATAD5040*	ATAD5440*	ATAD5840*	ATAD6040*
		ATAD4444*	ATAD4844*	ATAD5044*	ATAD5444*	ATAD5844*	ATAD6044*
		ATAD4448*	ATAD4848*	ATAD5048*	ATAD5448*	ATAD5848*	ATAD6048*

\*"Window Dimension" always refers to outside frame to frame dimension.  
 \*"Minimum Rough Opening" dimensions may need to be increased to allow for use of building wraps, flashing, sill panning, brackets, fasteners or other items. See installation information on page 170.  
 • Dimensions in parentheses are in millimeters.  
 \*Tempered laminated glass required. Some visual distortion may occur.

Notes on page 85 also apply to this page. Arch sizes on pages 76-88.

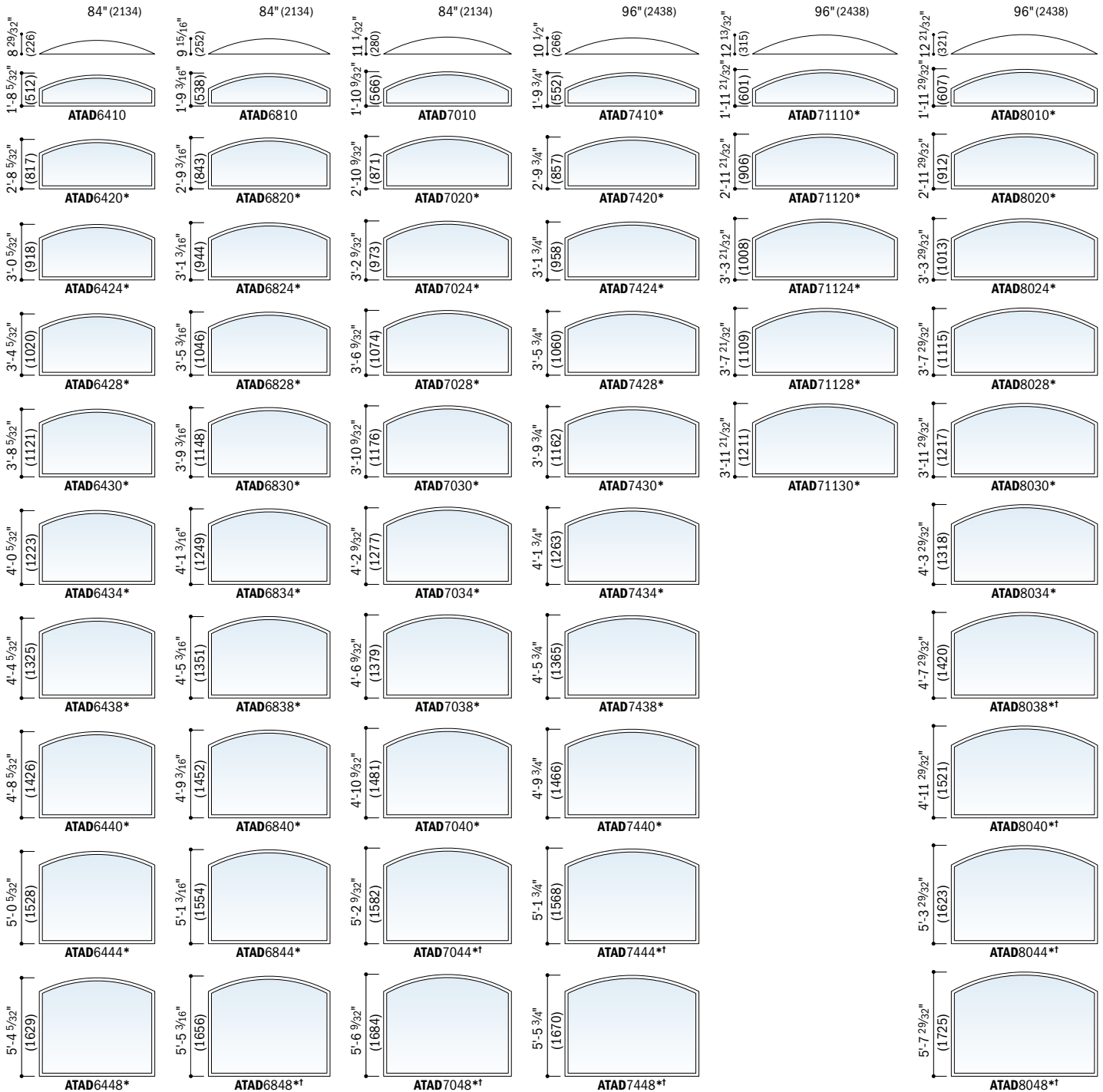
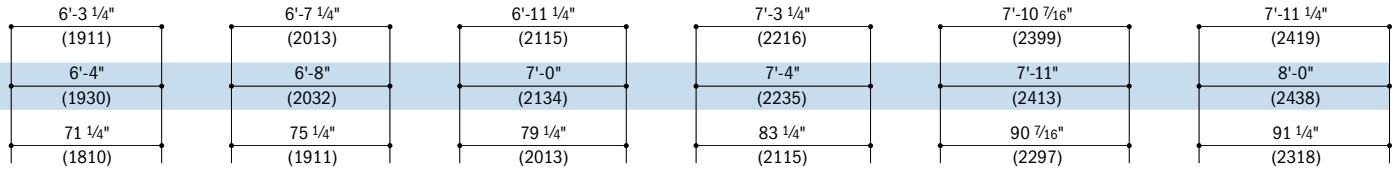

• "Window Dimension" always refers to outside frame to frame dimension.  
 • "Minimum Rough Opening" dimensions may need to be increased to allow for use of building wraps, flashing, sill panning, brackets, fasteners or other items. See installation information on page 170.  
 • Dimensions in parentheses are in millimeters.  
 \*Tempered laminated glass required. Some visual distortion may occur.  
 †Heat strengthened laminated glass required. Some visual distortion may occur.

continued on next page

**Table of Direct-Set Arch Window Sizes** (continued)

Notes on the next page also apply to this page.

Scale 1/8" (3) = 1'-0" (305) – 1:96

Window Dimension	4'-3 1/4" (1302)	4'-7 1/4" (1403)	4'-11 1/4" (1505)	5'-3 1/4" (1607)	5'-7 1/4" (1708)	5'-11 1/4" (1810)
<b>Minimum Rough Opening</b>	4'-4" (1321)	4'-8" (1422)	5'-0" (1524)	5'-4" (1626)	5'-8" (1727)	6'-0" (1829)
Unobstructed Glass	47 1/4" (1200)	51 1/4" (1302)	55 1/4" (1403)	59 1/4" (1505)	63 1/4" (1607)	67 1/4" (1708)

**CUSTOM SIZES AVAILABLE**

**Minimum Rough Opening = overall window height + 3/4" (19)**  
 Unobstructed Glass = window height - 4" (102)

**CUSTOM SIZES AVAILABLE**

Overall window height shown in table	Radius	Chord Height	Side Height	Model
59 1/4" (1505)	60" (1524)	5 3/4" (146)	59 1/4" (1505) 5'-5" (1651)	ATAD4450*
63 1/4" (1607)	60" (1524)	6 3/4" (171)	5'-6" (1676)	ATAD4850*
67 1/4" (1708)	60" (1524)	7 13/16" (199)	5'-7 1/16" (1704)	ATAD5050*
71 1/4" (1810)	60" (1524)	7 9/16" (186)	5'-6 9/16" (1691)	ATAD5450*
75 1/4" (1911)	72" (1829)	8 11/32" (212)	5'-7 19/32" (1717)	ATAD5850*
79 1/4" (2013)	72" (1829)	9 7/16" (240)	5'-8 11/16" (1745)	ATAD6050*
87 1/4" (2216)	72" (1829)			
63 1/4" (1607)			5'-10" (1778)	ATAD4454*
67 1/4" (1708)			5'-10 1/16" (1805)	ATAD4854*
71 1/4" (1810)			5'-11 1/16" (1832)	ATAD5054*
75 1/4" (1911)			5'-10 9/16" (1792)	ATAD5454*
79 1/4" (2013)			5'-11 19/32" (1818)	ATAD5854*
87 1/4" (2216)			6'-0 11/16" (1846)	ATAD6054*
67 1/4" (1708)			6'-2" (1879)	ATAD4458*
71 1/4" (1810)			6'-2 3/16" (1907)	ATAD4858*
75 1/4" (1911)			6'-3 1/16" (1934)	ATAD5058*
79 1/4" (2013)			6'-2 9/16" (1894)	ATAD5458*
87 1/4" (2216)			6'-3 19/32" (1920)	ATAD5858*
71 1/4" (1810)			6'-6" (1951)	ATAD4460*
75 1/4" (1911)			6'-6 1/16" (2008)	ATAD4860*
79 1/4" (2013)			6'-7 1/16" (2088)	ATAD5060*
87 1/4" (2216)			6'-6 9/16" (1996)	ATAD5460*
71 1/4" (1810)			6'-7 19/32" (2021)	ATAD5860*
75 1/4" (1911)			6'-8 1/16" (2049)	ATAD6060*
79 1/4" (2013)				
87 1/4" (2216)				
75 1/4" (1911)			6'-10" (2082)	ATAD4464*
79 1/4" (2013)			6'-10 1/16" (2110)	ATAD4864*
87 1/4" (2216)			6'-11 1/16" (2184)	ATAD5064*
75 1/4" (1911)			6'-10 9/16" (2097)	ATAD5464*
79 1/4" (2013)			6'-11 19/32" (2123)	ATAD5864*
87 1/4" (2216)			7'-0 11/16" (2151)	ATAD6064*
79 1/4" (2013)			7'-2" (2184)	ATAD4468*
83 1/4" (2115)			7'-2 3/16" (2212)	ATAD4868*
87 1/4" (2216)			7'-3 1/16" (2240)	ATAD5068*
83 1/4" (2115)			7'-2 9/16" (2199)	ATAD5468*
87 1/4" (2216)			7'-3 19/32" (2225)	ATAD5868*
91 1/4" (2317)			7'-4 1/16" (2253)	ATAD6068*
87 1/4" (2216)				
91 1/4" (2317)				
95 1/4" (2419)				
99 1/4" (2521)				
103 1/4" (2623)				
107 1/4" (2725)				
111 1/4" (2827)				
115 1/4" (2929)				
119 1/4" (3031)				
123 1/4" (3133)				
127 1/4" (3235)				
131 1/4" (3337)				
135 1/4" (3439)				
139 1/4" (3541)				
143 1/4" (3643)				
147 1/4" (3745)				
151 1/4" (3847)				
155 1/4" (3949)				
159 1/4" (4051)				
163 1/4" (4153)				
167 1/4" (4255)				
171 1/4" (4357)				
175 1/4" (4459)				
179 1/4" (4561)				
183 1/4" (4663)				
187 1/4" (4765)				
191 1/4" (4867)				
195 1/4" (4969)				
199 1/4" (5071)				
203 1/4" (5173)				
207 1/4" (5275)				
211 1/4" (5377)				
215 1/4" (5479)				
219 1/4" (5581)				
223 1/4" (5683)				
227 1/4" (5785)				
231 1/4" (5887)				
235 1/4" (5989)				
239 1/4" (6091)				
243 1/4" (6193)				
247 1/4" (6295)				
251 1/4" (6397)				
255 1/4" (6499)				
259 1/4" (6601)				
263 1/4" (6703)				
267 1/4" (6805)				
271 1/4" (6907)				
275 1/4" (7009)				
279 1/4" (7111)				
283 1/4" (7213)				
287 1/4" (7315)				
291 1/4" (7417)				
295 1/4" (7519)				
299 1/4" (7621)				
303 1/4" (7723)				
307 1/4" (7825)				
311 1/4" (7927)				
315 1/4" (8029)				
319 1/4" (8131)				
323 1/4" (8233)				
327 1/4" (8335)				
331 1/4" (8437)				
335 1/4" (8539)				
339 1/4" (8641)				
343 1/4" (8743)				
347 1/4" (8845)				
351 1/4" (8947)				
355 1/4" (9049)				
359 1/4" (9151)				
363 1/4" (9253)				
367 1/4" (9355)				
371 1/4" (9457)				
375 1/4" (9559)				
379 1/4" (9661)				
383 1/4" (9763)				
387 1/4" (9865)				
391 1/4" (9967)				
395 1/4" (10069)				
399 1/4" (10171)				
403 1/4" (10273)				
407 1/4" (10375)				
411 1/4" (10477)				
415 1/4" (10579)				
419 1/4" (10681)				
423 1/4" (10783)				
427 1/4" (10885)				
431 1/4" (10987)				
435 1/4" (11089)				
439 1/4" (11191)				
443 1/4" (11293)				
447 1/4" (11395)				
451 1/4" (11497)				
455 1/4" (11599)				
459 1/4" (11701)				
463 1/4" (11803)				
467 1/4" (11905)				
471 1/4" (12007)				
475 1/4" (12109)				
479 1/4" (12211)				
483 1/4" (12313)				
487 1/4" (12415)				
491 1/4" (12517)				
495 1/4" (12619)				
499 1/4" (12721)				
503 1/4" (12823)				
507 1/4" (12925)				
511 1/4" (13027)				
515 1/4" (13129)				
519 1/4" (13231)				
523 1/4" (13333)				
527 1/4" (13435)				
531 1/4" (13537)				
535 1/4" (13639)				
539 1/4" (13741)				
543 1/4" (13843)				
547 1/4" (13945)				
551 1/4" (14047)				
555 1/4" (14149)				
559 1/4" (14251)				
563 1/4" (14353)				
567 1/4" (14455)				
571 1/4" (14557)				
575 1/4" (14659)				
579 1/4" (14761)				
583 1/4" (14863)				
587 1/4" (14965)				
591 1/4" (15067)				
595 1/4" (15169)				
599 1/4" (15271)				
603 1/4" (15373)				
607 1/4" (15475)				
611 1/4" (15577)				
615 1/4" (15679)				
619 1/4" (15781)				
623 1/4" (15883)				
627 1/4" (15985)				
631 1/4" (16087)				
635 1/4" (16189)				
639 1/4" (16291)				
643 1/4" (16393)				
647 1/4" (16495)				
651 1/4" (16597)				
655 1/4" (16699)				
659 1/4" (16801)				
663 1/4" (16903)				
667 1/4" (17005)				
671 1/4" (17107)				
675 1/4" (17209)				
679 1/4" (17311)				
683 1/4" (17413)				
687 1/4" (17515)				
691 1/4" (17617)				
695 1/4" (17719)				
699 1/4" (17821)				
703 1/4" (17923)				
707 1/4" (18025)				
711 1/4" (18127)				
715 1/4" (18229)				
719 1/4" (18331)				
723 1/4" (18433)				
727 1/4" (18535)				
731 1/4" (18637)				
735 1/4" (18739)				
739 1/4" (18841)				
743 1/4" (18943)				
747 1/4" (19045)				
751 1/4" (19147)				
755 1/4" (19249)				
759 1/4" (19351)				
763 1/4" (19453)				
767 1/4" (19555)				
771 1/4" (19657)				
775 1/4" (19759)				
779 1/4" (19861)				
783 1/4" (19963)				
787 1/4" (20065)				
791 1/4" (20167)				
795 1/4" (20269)				
799 1/4" (20371)				
803 1/4" (20473)				
807 1/4" (20575)				
811 1/4" (20677)				
815 1/4" (20779)				
819 1/4" (20881)				
823 1/4" (20983)				
827 1/4" (21085)				
831 1/4" (21187)				
835 1/4" (21289)				

Arch sizes on pages 76-88.

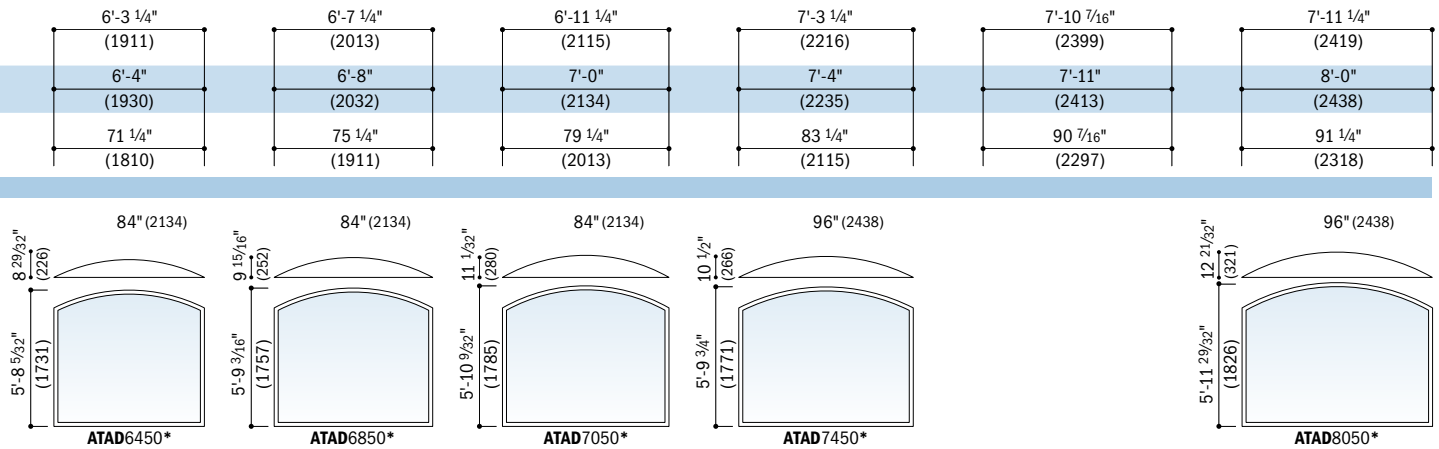

continued on next page

**Direct-Set Arch Window Area Specifications** (continued from page 81)

Window Number	Glass Area Sq. Ft./ (m <sup>2</sup> )	Window Number	Glass Area Sq. Ft./ (m <sup>2</sup> )	Window Number	Glass Area Sq. Ft./ (m <sup>2</sup> )
ATAD4864	27.06 (2.51)	ATAD5810	5.76 (0.54)	ATAD6434	20.53 (1.91)
ATAD4868	28.49 (2.65)	ATAD5820	11.04 (1.03)	ATAD6438	22.51 (2.09)
ATAD4874	31.33 (2.91)	ATAD5824	12.79 (1.19)	ATAD6440	24.49 (2.28)
ATAD4880	34.18 (3.18)	ATAD5828	14.55 (1.35)	ATAD6444	26.47 (2.46)
ATAD5010	4.91 (0.46)	ATAD5830	16.31 (1.52)	ATAD6448	28.45 (2.64)
ATAD5020	9.52 (0.88)	ATAD5834	18.06 (1.68)	ATAD6450	30.42 (2.83)
ATAD5024	11.05 (1.03)	ATAD5838	19.82 (1.84)	ATAD6810	7.42 (0.69)
ATAD5028	12.58 (1.17)	ATAD5840	21.58 (2.00)	ATAD6820	13.70 (1.27)
ATAD5030	14.12 (1.31)	ATAD5844	23.33 (2.17)	ATAD6824	15.79 (1.47)
ATAD5034	15.65 (1.45)	ATAD5848	25.09 (2.33)	ATAD6828	17.88 (1.66)
ATAD5038	17.19 (1.60)	ATAD5850	26.85 (2.49)	ATAD6830	19.97 (1.86)
ATAD5040	18.72 (1.74)	ATAD5854	28.60 (2.66)	ATAD6834	22.06 (2.05)
ATAD5044	20.26 (1.88)	ATAD5858	30.36 (2.82)	ATAD6838	24.15 (2.24)
ATAD5048	21.79 (2.02)	ATAD5860	32.12 (2.98)	ATAD6840	26.24 (2.44)
ATAD5050	23.33 (2.17)	ATAD5864	33.88 (3.15)	ATAD6844	28.33 (2.63)
ATAD5054	24.86 (2.31)	ATAD5868	35.63 (3.31)	ATAD6848	30.42 (2.83)
ATAD5058	26.40 (2.45)	ATAD5874	39.15 (3.64)	ATAD6850	32.51 (3.02)
ATAD5060	27.93 (2.59)	ATAD5880	42.66 (3.96)	ATAD7010	8.24 (0.77)
ATAD5064	29.47 (2.74)	ATAD6010	6.49 (0.60)	ATAD7020	14.85 (1.38)
ATAD5068	31.00 (2.88)	ATAD6020	12.09 (1.12)	ATAD7024	17.05 (1.58)
ATAD5074	34.07 (3.17)	ATAD6024	13.96 (1.30)	ATAD7028	19.25 (1.79)
ATAD5080	37.14 (3.45)	ATAD6028	15.83 (1.47)	ATAD7030	21.45 (1.99)
ATAD5410	5.11 (0.47)	ATAD6030	17.69 (1.64)	ATAD7034	23.65 (2.20)
ATAD5420	10.05 (0.93)	ATAD6034	19.56 (1.82)	ATAD7038	25.85 (2.40)
ATAD5424	11.69 (1.09)	ATAD6038	21.43 (1.99)	ATAD7040	28.05 (2.61)
ATAD5428	13.34 (1.24)	ATAD6040	23.30 (2.16)	ATAD7044	30.26 (2.81)
ATAD5430	14.98 (1.39)	ATAD6044	25.17 (2.34)	ATAD7048	32.46 (3.02)
ATAD5434	16.63 (1.54)	ATAD6048	27.03 (2.51)	ATAD7050	34.66 (3.22)
ATAD5438	18.28 (1.70)	ATAD6050	28.90 (2.68)	ATAD7410	8.42 (0.78)
ATAD5440	19.92 (1.85)	ATAD6054	30.77 (2.86)	ATAD7420	15.36 (1.43)
ATAD5444	21.57 (2.00)	ATAD6058	32.64 (3.03)	ATAD7424	17.67 (1.64)
ATAD5448	23.21 (2.16)	ATAD6060	34.51 (3.21)	ATAD7428	19.98 (1.86)
ATAD5450	24.86 (2.31)	ATAD6064	36.37 (3.38)	ATAD7430	22.30 (2.07)
ATAD5454	26.51 (2.46)	ATAD6068	38.24 (3.55)	ATAD7434	24.61 (2.29)
ATAD5458	28.15 (2.62)	ATAD6074	41.98 (3.90)	ATAD7438	26.92 (2.50)
ATAD5460	29.80 (2.77)	ATAD6410	6.67 (0.62)	ATAD7440	29.23 (2.72)
ATAD5464	31.44 (2.92)	ATAD6420	12.61 (1.17)	ATAD7444	31.55 (2.93)
ATAD5468	33.09 (3.07)	ATAD6424	14.59 (1.36)	ATAD7448	33.86 (3.15)
ATAD5474	36.38 (3.38)	ATAD6428	16.57 (1.54)	ATAD7450	36.17 (3.36)
ATAD5480	39.67 (3.69)	ATAD6430	18.55 (1.72)		

\*Dimensions in parentheses are in square meters.

continued on next page



Custom-size windows are available in 1/8" (3) increments. Contact your Andersen supplier for more information.

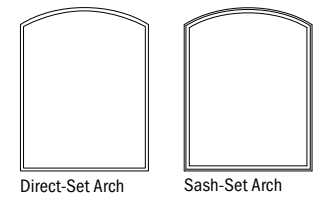

**Direct-set (ATAD) window sizes shown.** Use window dimensions and minimum rough opening formula shown for sash-set (ATA) window sizes. For sash-set unobstructed glass dimensions, see page 86.

Details shown on page 101. Grille patterns shown on page 97.

\*"Window Dimension" always refers to outside frame to frame dimension.  
 • "Minimum Rough Opening" dimensions may need to be increased to allow for use of building wraps, flashing, sill panning, brackets, fasteners or other items. See installation information on page 170.  
 • Dimensions in parentheses are in millimeters.  
 \*Tempered laminated glass required. Some visual distortion may occur.

**Table of Direct-Set Arch Window Sizes** (continued)

Notes on page 88 also apply to this page. Arch sizes on pages 76-88.

Scale 1/8" (3) = 1'-0" (305) – 1:96

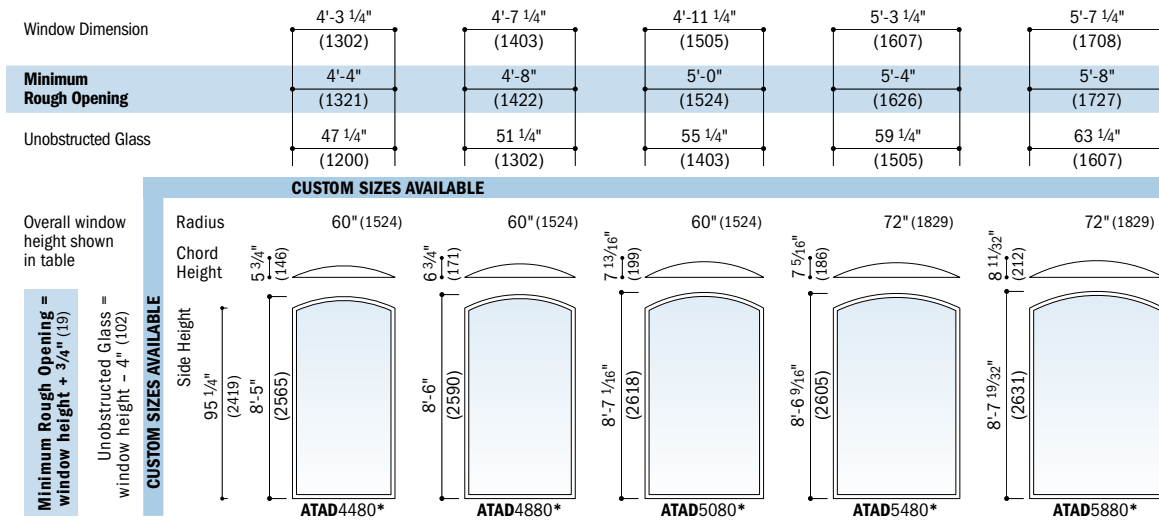

- "Window Dimension" always refers to outside frame to frame dimension.
- "Minimum Rough Opening" dimensions may need to be increased to allow for use of building wraps, flashing, sill panning, brackets, fasteners or other items. See installation information on page 170.
- Dimensions in parentheses are in millimeters.
- Tempered laminated glass required. Some visual distortion may occur.

continued on page 88

**Direct-Set Arch Window Area Specifications** (continued)

Window Number	Glass Area Sq. Ft./ (m <sup>2</sup> )	Window Number	Glass Area Sq. Ft./ (m <sup>2</sup> )	Window Number	Glass Area Sq. Ft./ (m <sup>2</sup> )	Window Number	Glass Area Sq. Ft./ (m <sup>2</sup> )
ATAD71110	9.99 (0.93)	ATAD8040	32.99 (3.06)	ATAD8844	38.15 (3.54)	ATAD9434	33.31 (3.09)
ATAD71120	17.52 (1.63)	ATAD8044	35.53 (3.30)	ATAD8848	40.90 (3.80)	ATAD9438	36.29 (3.37)
ATAD71124	20.04 (1.86)	ATAD8048	38.06 (3.54)	ATAD81110	11.30 (1.05)	ATAD9440	39.27 (3.65)
ATAD71128	22.55 (2.09)	ATAD8050	40.60 (3.77)	ATAD81120	19.83 (1.84)	ATAD10010	14.60 (1.36)
ATAD71130	25.06 (2.33)	ATAD8810	10.58 (0.98)	ATAD81124	22.68 (2.11)	ATAD10020	24.20 (2.25)
ATAD8010	10.18 (0.95)	ATAD8820	18.85 (1.75)	ATAD81128	25.52 (2.37)	ATAD10024	27.40 (2.55)
ATAD8020	17.78 (1.65)	ATAD8824	21.60 (2.01)	ATAD81130	28.37 (2.64)	ATAD10028	30.60 (2.84)
ATAD8024	20.32 (1.89)	ATAD8828	24.36 (2.26)	ATAD9410	12.46 (1.16)	ATAD10030	33.80 (3.14)
ATAD8028	22.85 (2.12)	ATAD8830	27.12 (2.52)	ATAD9420	21.39 (1.99)	ATAD10034	37.01 (3.44)
ATAD8030	25.39 (2.36)	ATAD8834	29.87 (2.78)	ATAD9424	24.37 (2.26)	ATAD10038	40.21 (3.74)
ATAD8034	27.92 (2.59)	ATAD8838	32.63 (3.03)	ATAD9428	27.35 (2.54)		
ATAD8038	30.46 (2.83)	ATAD8840	35.39 (3.29)	ATAD9430	30.33 (2.82)		

• Dimensions in parentheses are in square meters.

**Sash-Set Arch Window Unobstructed Glass Dimensions and Area Specifications**

Window Number	Unobstructed Glass Width Inches/(mm)	Unobstructed Glass Height Inches/(mm)	Glass Area Sq. Ft./ (m <sup>2</sup> )	Window Number	Unobstructed Glass Width Inches/(mm)	Unobstructed Glass Height Inches/(mm)	Glass Area Sq. Ft./ (m <sup>2</sup> )	Window Number	Unobstructed Glass Width Inches/(mm)	Unobstructed Glass Height Inches/(mm)	Glass Area Sq. Ft./ (m <sup>2</sup> )
ATA2010	16 5/8" (422)	7 5/8" (194)	0.81 (0.08)	ATA2128	17 1/2" (445)	27 1/8" (689)	3.23 (0.30)	ATA2620	22 5/8" (575)	20 3/8" (518)	3.07 (0.29)
ATA2020	16 5/8" (422)	19 5/8" (498)	2.19 (0.20)	ATA2130	17 1/2" (445)	31 1/8" (791)	3.72 (0.35)	ATA2624	22 5/8" (575)	24 3/8" (619)	3.70 (0.34)
ATA2024	16 5/8" (422)	23 5/8" (600)	2.65 (0.25)	ATA2410	20 5/8" (524)	7 7/8" (200)	1.03 (0.10)	ATA2628	22 5/8" (575)	28 3/8" (721)	4.33 (0.40)
ATA2028	16 5/8" (422)	27 5/8" (702)	3.11 (0.29)	ATA2420	20 5/8" (524)	19 7/8" (505)	2.74 (0.25)	ATA2630	22 5/8" (575)	32 3/8" (822)	4.95 (0.46)
ATA2030	16 5/8" (422)	31 5/8" (803)	3.58 (0.33)	ATA2424	20 5/8" (524)	23 7/8" (606)	3.32 (0.31)	ATA2634	22 5/8" (575)	36 3/8" (924)	5.58 (0.52)
ATA2034	16 5/8" (422)	35 5/8" (905)	4.04 (0.38)	ATA2428	20 5/8" (524)	27 7/8" (708)	3.89 (0.36)	ATA2638	22 5/8" (575)	40 3/8" (1026)	6.21 (0.58)
ATA2038	16 5/8" (422)	39 5/8" (1006)	4.50 (0.42)	ATA2430	20 5/8" (524)	31 7/8" (810)	4.46 (0.41)	ATA2640	22 5/8" (575)	44 3/8" (1127)	6.84 (0.64)
ATA2040	16 5/8" (422)	43 5/8" (1108)	4.96 (0.46)	ATA2434	20 5/8" (524)	35 7/8" (911)	5.03 (0.47)	ATA2644	22 5/8" (575)	48 3/8" (1229)	7.47 (0.69)
ATA2044	16 5/8" (422)	47 5/8" (1210)	5.42 (0.50)	ATA2438	20 5/8" (524)	39 7/8" (1013)	5.60 (0.52)	ATA2648	22 5/8" (575)	52 3/8" (1330)	8.09 (0.75)
ATA2048	16 5/8" (422)	51 5/8" (1311)	5.88 (0.55)	ATA2440	20 5/8" (524)	43 7/8" (1114)	6.18 (0.57)	ATA2650	22 5/8" (575)	56 3/8" (1432)	8.72 (0.81)
ATA2050	16 5/8" (422)	55 5/8" (1413)	6.34 (0.59)	ATA2444	20 5/8" (524)	47 7/8" (1216)	6.75 (0.63)	ATA2654	22 5/8" (575)	60 3/8" (1534)	9.35 (0.87)
ATA2054	16 5/8" (422)	59 5/8" (1514)	6.80 (0.63)	ATA2448	20 5/8" (524)	51 7/8" (1318)	7.32 (0.68)	ATA2658	22 5/8" (575)	64 3/8" (1635)	9.98 (0.93)
ATA2058	16 5/8" (422)	63 5/8" (1616)	7.26 (0.67)	ATA2450	20 5/8" (524)	55 7/8" (1419)	7.89 (0.73)	ATA2660	22 5/8" (575)	68 3/8" (1737)	10.60 (0.99)
ATA2060	16 5/8" (422)	67 5/8" (1718)	7.72 (0.72)	ATA2454	20 5/8" (524)	59 7/8" (1521)	8.46 (0.79)	ATA2664	22 5/8" (575)	72 3/8" (1838)	11.23 (1.04)
ATA2064	16 5/8" (422)	71 5/8" (1819)	8.18 (0.76)	ATA2458	20 5/8" (524)	63 7/8" (1622)	9.04 (0.84)	ATA2668	22 5/8" (575)	76 3/8" (1940)	11.86 (1.10)
ATA2068	16 5/8" (422)	75 5/8" (1921)	8.65 (0.80)	ATA2460	20 5/8" (524)	67 7/8" (1724)	9.61 (0.89)	ATA2674	22 5/8" (575)	84 3/8" (2143)	13.11 (1.22)
ATA2074	16 5/8" (422)	83 5/8" (2124)	9.57 (0.89)	ATA2464	20 5/8" (524)	71 7/8" (1826)	10.18 (0.95)	ATA2680	22 5/8" (575)	92 3/8" (2346)	14.37 (1.34)
ATA2080	16 5/8" (422)	91 5/8" (2327)	10.49 (0.97)	ATA2468	20 5/8" (524)	75 7/8" (1927)	10.75 (1.00)	ATA2710	23 1/2" (597)	7 7/8" (200)	1.17 (0.11)
ATA2110	17 1/2" (445)	7 7/8" (181)	0.81 (0.08)	ATA2474	20 5/8" (524)	83 7/8" (2130)	11.90 (1.11)	ATA2720	23 1/2" (597)	19 7/8" (505)	3.13 (0.29)
ATA2120	17 1/2" (445)	19 1/8" (486)	2.26 (0.21)	ATA2480	20 5/8" (524)	91 7/8" (2334)	13.04 (1.21)				
ATA2124	17 1/2" (445)	23 1/8" (587)	2.75 (0.26)	ATA2610	22 5/8" (575)	8 3/8" (213)	1.19 (0.11)				

• Dimensions in parentheses are in millimeters or square meters.

continued on next page



**Sash-Set Arch Window Unobstructed Glass Dimensions and Area Specifications** *(continued)*

Window Number	Unobstructed Glass Width Inches/(mm)	Unobstructed Glass Height Inches/(mm)	Glass Area Sq. Ft./ (m <sup>2</sup> )
ATA2724	23 1/2" (597)	23 7/8" (606)	3.78 (0.35)
ATA2728	23 1/2" (597)	27 1/8" (708)	4.43 (0.41)
ATA2730	23 1/2" (597)	31 7/8" (810)	5.08 (0.47)
ATA2810	24 5/8" (625)	8 3/16" (208)	1.26 (0.12)
ATA2820	24 5/8" (625)	20 3/16" (513)	3.31 (0.31)
ATA2824	24 5/8" (625)	24 3/16" (614)	3.99 (0.37)
ATA2828	24 5/8" (625)	28 3/16" (716)	4.68 (0.43)
ATA2830	24 5/8" (625)	32 3/16" (818)	5.36 (0.50)
ATA2834	24 5/8" (625)	36 3/16" (919)	6.04 (0.56)
ATA2838	24 5/8" (625)	40 3/16" (1021)	6.72 (0.62)
ATA2840	24 5/8" (625)	44 3/16" (1122)	7.41 (0.69)
ATA2844	24 5/8" (625)	48 3/16" (1224)	8.09 (0.75)
ATA2848	24 5/8" (625)	52 3/16" (1326)	8.77 (0.81)
ATA2850	24 5/8" (625)	56 3/16" (1427)	9.46 (0.88)
ATA2854	24 5/8" (625)	60 3/16" (1529)	10.14 (0.94)
ATA2858	24 5/8" (625)	64 3/16" (1630)	10.82 (1.01)
ATA2860	24 5/8" (625)	68 3/16" (1732)	11.51 (1.07)
ATA2864	24 5/8" (625)	72 3/16" (1834)	12.19 (1.13)
ATA2868	24 5/8" (625)	76 3/16" (1935)	12.87 (1.20)
ATA2874	24 5/8" (625)	84 3/16" (2138)	14.24 (1.32)
ATA2880	24 5/8" (625)	92 3/16" (2342)	15.61 (1.45)
ATA2910	25 1/2" (648)	8 3/8" (213)	1.33 (0.12)
ATA2920	25 1/2" (648)	20 3/8" (518)	3.45 (0.32)
ATA2924	25 1/2" (648)	24 3/8" (619)	4.16 (0.39)
ATA2928	25 1/2" (648)	28 3/8" (721)	4.87 (0.45)
ATA2930	25 1/2" (648)	32 3/8" (822)	5.58 (0.52)
ATA2910G	25 3/4" (654)	8 7/16" (214)	1.35 (0.13)
ATA2920G	25 3/4" (654)	20 7/16" (519)	3.50 (0.33)
ATA2924G	25 3/4" (654)	24 7/16" (621)	4.21 (0.39)
ATA2928G	25 3/4" (654)	28 7/16" (722)	4.92 (0.46)
ATA2930G	25 3/4" (654)	32 7/16" (824)	5.64 (0.52)
ATA21010	26 5/8" (676)	8 11/16" (221)	1.43 (0.13)
ATA21020	26 5/8" (676)	20 11/16" (525)	3.65 (0.34)
ATA21024	26 5/8" (676)	24 11/16" (627)	4.38 (0.41)
ATA21028	26 5/8" (676)	28 11/16" (729)	5.12 (0.48)
ATA21030	26 5/8" (676)	32 11/16" (830)	5.86 (0.54)
ATA21034	26 5/8" (676)	36 11/16" (932)	6.60 (0.61)
ATA21038	26 5/8" (676)	40 11/16" (1033)	7.34 (0.68)
ATA21040	26 5/8" (676)	44 11/16" (1135)	8.08 (0.75)
ATA21044	26 5/8" (676)	48 11/16" (1237)	8.82 (0.82)
ATA21048	26 5/8" (676)	52 11/16" (1338)	9.55 (0.89)
ATA21050	26 5/8" (676)	56 11/16" (1440)	10.29 (0.96)
ATA21054	26 5/8" (676)	60 11/16" (1541)	11.03 (1.02)
ATA21058	26 5/8" (676)	64 11/16" (1643)	11.77 (1.09)
ATA21060	26 5/8" (676)	68 11/16" (1745)	12.51 (1.16)
ATA21064	26 5/8" (676)	72 11/16" (1846)	13.25 (1.23)
ATA21068	26 5/8" (676)	76 11/16" (1948)	13.99 (1.30)
ATA21074	26 5/8" (676)	84 11/16" (2151)	15.46 (1.44)
ATA21080	26 5/8" (676)	92 11/16" (2354)	16.94 (1.57)
ATA3010	28 5/8" (727)	9 3/16" (233)	1.61 (0.15)
ATA3020	28 5/8" (727)	21 3/16" (538)	4.00 (0.37)
ATA3024	28 5/8" (727)	25 3/16" (640)	4.79 (0.45)
ATA3028	28 5/8" (727)	29 3/16" (741)	5.59 (0.52)
ATA3030	28 5/8" (727)	33 3/16" (843)	6.38 (0.59)
ATA3034	28 5/8" (727)	37 3/16" (945)	7.17 (0.67)
ATA3038	28 5/8" (727)	41 3/16" (1046)	7.97 (0.74)
ATA3040	28 5/8" (727)	45 3/16" (1148)	8.76 (0.81)
ATA3044	28 5/8" (727)	49 3/16" (1249)	9.56 (0.89)
ATA3048	28 5/8" (727)	53 3/16" (1351)	10.35 (0.96)
ATA3050	28 5/8" (727)	57 3/16" (1453)	11.15 (1.04)

Window Number	Unobstructed Glass Width Inches/(mm)	Unobstructed Glass Height Inches/(mm)	Glass Area Sq. Ft./ (m <sup>2</sup> )
ATA3054	28 5/8" (727)	61 3/16" (1554)	11.94 (1.11)
ATA3058	28 5/8" (727)	65 3/16" (1656)	12.73 (1.18)
ATA3060	28 5/8" (727)	69 3/16" (1757)	13.53 (1.26)
ATA3064	28 5/8" (727)	73 3/16" (1859)	14.32 (1.33)
ATA3068	28 5/8" (727)	77 3/16" (1961)	15.12 (1.40)
ATA3074	28 5/8" (727)	85 3/16" (2164)	16.71 (1.55)
ATA3080	28 5/8" (727)	93 3/16" (2367)	18.29 (1.70)
ATA3110	29 1/2" (749)	9 7/16" (240)	1.70 (0.16)
ATA3120	29 1/2" (749)	21 7/16" (545)	4.16 (0.39)
ATA3124	29 1/2" (749)	25 7/16" (646)	4.97 (0.46)
ATA3128	29 1/2" (749)	29 7/16" (748)	5.79 (0.54)
ATA3130	29 1/2" (749)	33 7/16" (849)	6.61 (0.61)
ATA3210	30 5/8" (778)	8 15/16" (227)	1.68 (0.16)
ATA3220	30 5/8" (778)	20 15/16" (532)	4.23 (0.39)
ATA3224	30 5/8" (778)	24 15/16" (633)	5.08 (0.47)
ATA3228	30 5/8" (778)	28 15/16" (735)	5.93 (0.55)
ATA3230	30 5/8" (778)	32 15/16" (837)	6.78 (0.63)
ATA3234	30 5/8" (778)	36 15/16" (938)	7.63 (0.71)
ATA3238	30 5/8" (778)	40 15/16" (1040)	8.48 (0.79)
ATA3240	30 5/8" (778)	44 15/16" (1141)	9.33 (0.87)
ATA3244	30 5/8" (778)	48 15/16" (1243)	10.18 (0.95)
ATA3248	30 5/8" (778)	52 15/16" (1345)	11.03 (1.02)
ATA3250	30 5/8" (778)	56 15/16" (1446)	11.88 (1.10)
ATA3254	30 5/8" (778)	60 15/16" (1548)	12.73 (1.18)
ATA3258	30 5/8" (778)	64 15/16" (1649)	13.58 (1.26)
ATA3260	30 5/8" (778)	68 15/16" (1751)	14.43 (1.34)
ATA3264	30 5/8" (778)	72 15/16" (1853)	15.28 (1.42)
ATA3268	30 5/8" (778)	76 15/16" (1954)	16.13 (1.50)
ATA3274	30 5/8" (778)	84 15/16" (2157)	17.83 (1.66)
ATA3280	30 5/8" (778)	92 15/16" (2361)	19.53 (1.81)
ATA3310	31 1/2" (800)	9 3/16" (233)	1.76 (0.16)
ATA3320	31 1/2" (800)	21 3/16" (538)	4.39 (0.41)
ATA3324	31 1/2" (800)	25 3/16" (640)	5.26 (0.49)
ATA3328	31 1/2" (800)	29 3/16" (741)	6.14 (0.57)
ATA3330	31 1/2" (800)	33 3/16" (843)	7.01 (0.65)
ATA3310G	31 3/4" (806)	9 1/2" (235)	1.79 (0.17)
ATA3320G	31 3/4" (806)	21 1/2" (540)	4.43 (0.41)
ATA3324G	31 3/4" (806)	25 1/2" (641)	5.31 (0.49)
ATA3328G	31 3/4" (806)	29 1/2" (743)	6.19 (0.58)
ATA3330G	31 3/4" (806)	33 1/2" (845)	7.08 (0.66)
ATA3410	32 5/8" (829)	9 7/16" (240)	1.88 (0.17)
ATA3420	32 5/8" (829)	21 7/16" (545)	4.59 (0.43)
ATA3424	32 5/8" (829)	25 7/16" (646)	5.50 (0.51)
ATA3428	32 5/8" (829)	29 7/16" (748)	6.40 (0.59)
ATA3430	32 5/8" (829)	33 7/16" (849)	7.31 (0.68)
ATA3434	32 5/8" (829)	37 7/16" (951)	8.21 (0.76)
ATA3438	32 5/8" (829)	41 7/16" (1053)	9.12 (0.85)
ATA3440	32 5/8" (829)	45 7/16" (1154)	10.02 (0.93)
ATA3444	32 5/8" (829)	49 7/16" (1256)	10.93 (1.02)
ATA3448	32 5/8" (829)	53 7/16" (1357)	11.83 (1.10)
ATA3450	32 5/8" (829)	57 7/16" (1459)	12.74 (1.18)
ATA3454	32 5/8" (829)	61 7/16" (1561)	13.65 (1.27)
ATA3458	32 5/8" (829)	65 7/16" (1662)	14.55 (1.35)
ATA3460	32 5/8" (829)	69 7/16" (1764)	15.46 (1.44)
ATA3464	32 5/8" (829)	73 7/16" (1865)	16.36 (1.52)
ATA3468	32 5/8" (829)	77 7/16" (1967)	17.27 (1.60)
ATA3474	32 5/8" (829)	85 7/16" (2170)	19.08 (1.77)
ATA3480	32 5/8" (829)	93 7/16" (2373)	20.89 (1.94)
ATA3810	36 5/8" (930)	9 3/4" (248)	2.15 (0.20)
ATA3820	36 5/8" (930)	21 3/4" (552)	5.20 (0.48)

Window Number	Unobstructed Glass Width Inches/(mm)	Unobstructed Glass Height Inches/(mm)	Glass Area Sq. Ft./ (m <sup>2</sup> )
ATA3824	36 5/8" (930)	25 3/4" (654)	6.22 (0.58)
ATA3828	36 5/8" (930)	29 3/4" (756)	7.23 (0.67)
ATA3830	36 5/8" (930)	33 3/4" (857)	8.25 (0.77)
ATA3834	36 5/8" (930)	37 3/4" (959)	9.27 (0.86)
ATA3838	36 5/8" (930)	41 3/4" (1060)	10.28 (0.96)
ATA3840	36 5/8" (930)	45 3/4" (1162)	11.30 (1.05)
ATA3844	36 5/8" (930)	49 3/4" (1264)	12.31 (1.14)
ATA3848	36 5/8" (930)	53 3/4" (1365)	13.33 (1.24)
ATA3850	36 5/8" (930)	57 3/4" (1467)	14.35 (1.33)
ATA3854	36 5/8" (930)	61 3/4" (1568)	15.36 (1.43)
ATA3858	36 5/8" (930)	65 3/4" (1670)	16.38 (1.52)
ATA3860	36 5/8" (930)	69 3/4" (1772)	17.40 (1.62)
ATA3864	36 5/8" (930)	73 3/4" (1873)	18.41 (1.71)
ATA3868	36 5/8" (930)	77 3/4" (1975)	19.43 (1.81)
ATA3874	36 5/8" (930)	85 3/4" (2178)	21.46 (1.99)
ATA3880	36 5/8" (930)	93 3/4" (2381)	23.50 (2.18)
ATA3910	37 3/4" (959)	10" (254)	2.27 (0.21)
ATA3920	37 3/4" (959)	22" (559)	5.41 (0.50)
ATA3924	37 3/4" (959)	26" (660)	6.46 (0.60)
ATA3928	37 3/4" (959)	30" (762)	7.51 (0.70)
ATA3930	37 3/4" (959)	34" (864)	8.56 (0.80)
ATA4010	40 5/8" (1032)	10 13/16" (275)	2.60 (0.24)
ATA4020	40 5/8" (1032)	22 13/16" (579)	5.98 (0.56)
ATA4024	40 5/8" (1032)	26 13/16" (681)	7.11 (0.66)
ATA4028	40 5/8" (1032)	30 13/16" (783)	8.24 (0.77)
ATA4030	40 5/8" (1032)	34 13/16" (884)	9.37 (0.87)
ATA4034	40 5/8" (1032)	38 13/16" (986)	10.49 (0.97)
ATA4038	40 5/8" (1032)	42 13/16" (1087)	11.62 (1.08)
ATA4040	40 5/8" (1032)	46 13/16" (1189)	12.75 (1.18)
ATA4044	40 5/8" (1032)	50 13/16" (1291)	13.88 (1.29)
ATA4048	40 5/8" (1032)	54 13/16" (1392)	15.00 (1.39)
ATA4050	40 5/8" (1032)	58 13/16" (1494)	16.13 (1.50)
ATA4054	40 5/8" (1032)	62 13/16" (1595)	17.26 (1.60)
ATA4058	40 5/8" (1032)	66 13/16" (1697)	18.39 (1.71)
ATA4060	40 5/8" (1032)	70 13/16" (1799)	19.51 (1.81)
ATA4064	40 5/8" (1032)	74 13/16" (1900)	20.64 (1.92)
ATA4068	40 5/8" (1032)	78 13/16" (2002)	21.77 (2.02)
ATA4074	40 5/8" (1032)	86 13/16" (2205)	24.02 (2.23)
ATA4080	40 5/8" (1032)	94 13/16" (2408)	26.28 (2.44)
ATA4310	43 3/4" (1111)	10 1/8" (257)	2.64 (0.25)
ATA4320	43 3/4" (1111)	22 1/8" (562)	6.28 (0.58)
ATA4324	43 3/4" (1111)	26 1/8" (664)	7.50 (0.70)
ATA4328	43 3/4" (1111)	30 1/8" (765)	8.71 (0.81)
ATA4330	43 3/4" (1111)	34 1/8" (867)	9.93 (0.92)
ATA4410	44 5/8" (1133)	10 5/16" (262)	2.74 (0.25)
ATA4420	44 5/8" (1133)	22 5/16" (567)	6.45 (0.60)
ATA4424	44 5/8" (1133)	26 5/16" (668)	7.69 (0.71)
ATA4428	44 5/8" (1133)	30 5/16" (770)	8.93 (0.83)
ATA4430	44 5/8" (1133)	34 5/16" (872)	10.17 (0.94)
ATA4434	44 5/8" (1133)	38 5/16" (973)	11.41 (1.06)
ATA4438	44 5/8" (1133)	42 5/16" (1075)	12.65 (1.18)
ATA4440	44 5/8" (1133)	46 5/16" (1176)	13.89 (1.29)
ATA4444	44 5/8" (1133)	50 5/16" (1278)	15.13 (1.41)
ATA4448	44 5/8" (1133)	54 5/16" (1380)	16.36 (1.52)
ATA4450	44 5/8" (1133)	58 5/16" (1481)	17.60 (1.64)
ATA4454	44 5/8" (1133)	62 5/16" (1583)	18.84 (1.75)
ATA4458	44 5/8" (1133)	66 5/16" (1684)	20.08 (1.87)
ATA4460	44 5/8" (1133)	70 5/16" (1786)	21.32 (1.98)
ATA4464	44 5/8" (1133)	74 5/16" (1888)	22.56 (2.10)

\* Dimensions in parentheses are in millimeters or square meters.

**Table of Direct-Set Arch Window Sizes** (continued from page 86)

Arch sizes on pages 76-88.

Scale 1/8" (3) = 1'-0" (305) – 1:96

Window Dimension	8'-7 1/4" (2623)	8'-10 7/16" (2704)	9'-3 1/4" (2826)	9'-11 1/4" (3029)
<b>Minimum Rough Opening</b>	8'-8" (2642)	8'-11" (2718)	9'-4" (2845)	10'-0" (3048)
Unobstructed Glass	99 1/4" (2521)	102 7/16" (2602)	107 1/4" (2724)	115 1/4" (2927)

Overall window height shown in table

**Minimum Rough Opening = overall window height + 3/4" (19)**

Unobstructed Glass = window height - 4" (102)

**CUSTOM SIZES AVAILABLE**

Radius	120" (3048)	120" (3048)	120" (3048)	120" (3048)
Chord Height	11 11/16" (296)	12 7/16" (316)	13 21/32" (347)	15 7/8" (403)
Side Height	11 1/4" (286)	11 11/16" (296)	2'-0 29/32" (633)	2'-3 1/8" (689)
	23 1/4" (591)	2'-11 11/16" (907)	3'-0 29/32" (938)	3'-3 1/8" (993)
	27 1/4" (692)	3'-3 11/16" (1008)	3'-4 29/32" (1039)	3'-7 1/8" (1095)
	31 1/4" (794)	3'-7 11/16" (1110)	3'-8 29/32" (1141)	3'-11 1/8" (1197)
	35 1/4" (895)	3'-11 11/16" (1211)	4'-0 29/32" (1243)	4'-3 1/8" (1298)
	39 1/4" (997)		4'-4 29/32" (1344)	4'-7 1/8" (1400)
	43 1/4" (1099)		4'-8 29/32" (1446)	4'-11 1/8" (1501)
	47 1/4" (1200)		5'-0 29/32" (1547)	
	51 1/4" (1302)			
	55 1/4" (1403)			

ATAD8810\* ATAD88110\* ATAD9410\* ATAD10010\*  
 ATAD8820\* ATAD81120\* ATAD9420\* ATAD10020\*  
 ATAD8824\* ATAD81124\* ATAD9424\* ATAD10024\*  
 ATAD8828\* ATAD81128\* ATAD9428\* ATAD10028\*  
 ATAD8830\* ATAD81130\* ATAD9430\* ATAD10030\*  
 ATAD8834\* ATAD9434\* ATAD10034\*  
 ATAD8838\* ATAD9438\* ATAD10038\*  
 ATAD8840\* ATAD9440\*  
 ATAD8844\*  
 ATAD8848\*

Custom-size windows are available in 1/8" (3) increments. Contact your Andersen supplier for more information.

**Direct-set (ATAD) window sizes shown.**  
 Use window dimensions and minimum rough opening formula shown for sash-set (ATA) window sizes. For sash-set unobstructed glass dimensions, see page 86.

Details shown on page 101.  
 Grille patterns shown on page 97.

\* "Window Dimension" always refers to outside frame to frame dimension.  
 \* "Minimum Rough Opening" dimensions may need to be increased to allow for use of building wraps, flashing, sill panning, brackets, fasteners or other items. See installation information on page 170.  
 \* Dimensions in parentheses are in millimeters.  
 \* Tempered laminated glass required. Some visual distortion may occur.

**Sash-Set Arch Window Unobstructed Glass**  
**Dimensions and Area Specifications** *(continued from page 87)*

Window Number	Unobstructed Glass Width Inches/(mm)	Unobstructed Glass Height Inches/(mm)	Glass Area Sq. Ft./ (m <sup>2</sup> )	Window Number	Unobstructed Glass Width Inches/(mm)	Unobstructed Glass Height Inches/(mm)	Glass Area Sq. Ft./ (m <sup>2</sup> )	Window Number	Unobstructed Glass Width Inches/(mm)	Unobstructed Glass Height Inches/(mm)	Glass Area Sq. Ft./ (m <sup>2</sup> )
ATA4468	44 5/8" (1133)	78 5/16" (1989)	23.80 (2.21)	ATA5830	60 5/8" (1540)	36 1/16" (938)	14.57 (1.35)	ATA7044	76 5/8" (1946)	55 5/8" (1413)	27.92 (2.59)
ATA4474	44 5/8" (1133)	86 5/16" (2192)	26.27 (2.44)	ATA5834	60 5/8" (1540)	40 15/16" (1040)	16.26 (1.51)	ATA7048	76 5/8" (1946)	59 5/8" (1514)	30.05 (2.79)
ATA4480	44 5/8" (1133)	94 5/16" (2396)	28.75 (2.67)	ATA5838	60 5/8" (1540)	44 15/16" (1141)	17.94 (1.67)	ATA7050	76 5/8" (1946)	63 5/8" (1616)	32.18 (2.99)
ATA4810	48 5/8" (1235)	11 5/16" (287)	3.22 (0.30)	ATA5840	60 5/8" (1540)	48 15/16" (1243)	19.62 (1.82)	ATA7410	80 5/8" (2048)	15 1/16" (383)	6.76 (0.63)
ATA4820	48 5/8" (1235)	23 5/16" (592)	7.27 (0.68)	ATA5844	60 5/8" (1540)	52 15/16" (1345)	21.30 (1.98)	ATA7420	80 5/8" (2048)	27 1/16" (687)	13.47 (1.25)
ATA4824	48 5/8" (1235)	27 5/16" (694)	8.62 (0.80)	ATA5848	60 5/8" (1540)	56 15/16" (1446)	22.99 (2.14)	ATA7424	80 5/8" (2048)	31 1/16" (789)	15.71 (1.46)
ATA4828	48 5/8" (1235)	31 5/16" (795)	9.97 (0.93)	ATA5850	60 5/8" (1540)	60 15/16" (1548)	24.67 (2.29)	ATA7428	80 5/8" (2048)	35 1/16" (891)	17.95 (1.67)
ATA4830	48 5/8" (1235)	35 5/16" (897)	11.32 (1.05)	ATA5854	60 5/8" (1540)	64 15/16" (1649)	26.35 (2.45)	ATA7430	80 5/8" (2048)	39 1/16" (992)	20.19 (1.88)
ATA4834	48 5/8" (1235)	39 5/16" (999)	12.67 (1.18)	ATA5858	60 5/8" (1540)	68 15/16" (1751)	28.04 (2.61)	ATA7434	80 5/8" (2048)	43 1/16" (1094)	22.43 (2.08)
ATA4838	48 5/8" (1235)	43 5/16" (1100)	14.02 (1.30)	ATA5860	60 5/8" (1540)	72 15/16" (1853)	29.72 (2.76)	ATA7438	80 5/8" (2048)	47 1/16" (1195)	24.66 (2.29)
ATA4840	48 5/8" (1235)	47 5/16" (1202)	15.37 (1.43)	ATA5864	60 5/8" (1540)	76 15/16" (1954)	31.40 (2.92)	ATA7440	80 5/8" (2048)	51 1/16" (1297)	26.90 (2.50)
ATA4844	48 5/8" (1235)	51 5/16" (1303)	16.72 (1.55)	ATA5868	60 5/8" (1540)	80 15/16" (2056)	33.09 (3.07)	ATA7444	80 5/8" (2048)	55 1/16" (1399)	29.14 (2.71)
ATA4848	48 5/8" (1235)	55 5/16" (1405)	18.07 (1.68)	ATA5874	60 5/8" (1540)	88 15/16" (2259)	36.45 (3.39)	ATA7448	80 5/8" (2048)	59 1/16" (1500)	31.38 (2.92)
ATA4850	48 5/8" (1235)	59 5/16" (1507)	19.42 (1.80)	ATA5880	60 5/8" (1540)	96 15/16" (2462)	39.82 (3.70)	ATA7450	80 5/8" (2048)	63 1/16" (1602)	33.62 (3.12)
ATA4854	48 5/8" (1235)	63 5/16" (1608)	20.77 (1.93)	ATA6010	64 5/8" (1641)	14" (356)	5.11 (0.47)	ATA71110	87 13/16" (2230)	17" (432)	8.18 (0.76)
ATA4858	48 5/8" (1235)	67 5/16" (1710)	22.12 (2.06)	ATA6020	64 5/8" (1641)	26" (660)	10.50 (0.98)	ATA71120	87 13/16" (2230)	29" (737)	15.49 (1.44)
ATA4860	48 5/8" (1235)	71 5/16" (1811)	23.47 (2.18)	ATA6024	64 5/8" (1641)	30" (762)	12.29 (1.14)	ATA71124	87 13/16" (2230)	33" (838)	17.93 (1.67)
ATA4864	48 5/8" (1235)	75 5/16" (1913)	24.82 (2.31)	ATA6028	64 5/8" (1641)	34" (864)	14.09 (1.31)	ATA71128	87 13/16" (2230)	37" (940)	20.37 (1.89)
ATA4868	48 5/8" (1235)	79 5/16" (2015)	26.17 (2.43)	ATA6030	64 5/8" (1641)	38" (965)	15.88 (1.48)	ATA71130	87 13/16" (2230)	41" (1041)	22.81 (2.12)
ATA4874	48 5/8" (1235)	87 5/16" (2218)	28.87 (2.68)	ATA6034	64 5/8" (1641)	42" (1067)	17.67 (1.64)	ATA8010	88 5/8" (2251)	17 1/4" (438)	8.35 (0.78)
ATA4880	48 5/8" (1235)	95 5/16" (2421)	31.57 (2.93)	ATA6038	64 5/8" (1641)	46" (1168)	19.47 (1.81)	ATA8020	88 5/8" (2251)	29 1/4" (743)	15.74 (1.46)
ATA5010	52 5/8" (1337)	12 1/16" (316)	3.77 (0.35)	ATA6040	64 5/8" (1641)	50" (1270)	21.26 (1.98)	ATA8024	88 5/8" (2251)	33 1/4" (845)	18.20 (1.69)
ATA5020	52 5/8" (1337)	24 1/16" (621)	8.15 (0.76)	ATA6044	64 5/8" (1641)	54" (1372)	23.06 (2.14)	ATA8028	88 5/8" (2251)	37 1/4" (946)	20.66 (1.92)
ATA5024	52 5/8" (1337)	28 1/16" (722)	9.61 (0.89)	ATA6048	64 5/8" (1641)	58" (1473)	24.85 (2.31)	ATA8030	88 5/8" (2251)	41 1/4" (1048)	23.12 (2.15)
ATA5028	52 5/8" (1337)	32 1/16" (824)	11.07 (1.03)	ATA6050	64 5/8" (1641)	62" (1575)	26.65 (2.48)	ATA8034	88 5/8" (2251)	45 1/4" (1149)	25.58 (2.38)
ATA5030	52 5/8" (1337)	36 1/16" (926)	12.53 (1.16)	ATA6054	64 5/8" (1641)	66" (1676)	28.44 (2.64)	ATA8038	88 5/8" (2251)	49 1/4" (1251)	28.04 (2.61)
ATA5034	52 5/8" (1337)	40 1/16" (1027)	13.99 (1.30)	ATA6058	64 5/8" (1641)	70" (1778)	30.23 (2.81)	ATA8040	88 5/8" (2251)	53 1/4" (1353)	30.50 (2.83)
ATA5038	52 5/8" (1337)	44 1/16" (1129)	15.45 (1.44)	ATA6060	64 5/8" (1641)	74" (1880)	32.03 (2.98)	ATA8044	88 5/8" (2251)	57 1/4" (1454)	32.96 (3.06)
ATA5040	52 5/8" (1337)	48 1/16" (1230)	16.92 (1.57)	ATA6064	64 5/8" (1641)	78" (1981)	33.82 (3.14)	ATA8048	88 5/8" (2251)	61 1/4" (1556)	35.42 (3.29)
ATA5044	52 5/8" (1337)	52 1/16" (1332)	18.38 (1.71)	ATA6068	64 5/8" (1641)	82" (2083)	35.62 (3.31)	ATA8050	88 5/8" (2251)	65 1/4" (1657)	37.89 (3.52)
ATA5048	52 5/8" (1337)	56 1/16" (1434)	19.84 (1.84)	ATA6074	64 5/8" (1641)	90" (2286)	39.21 (3.64)	ATA8810	96 5/8" (2454)	16 1/4" (413)	8.61 (0.80)
ATA5050	52 5/8" (1337)	60 1/16" (1535)	21.30 (1.98)	ATA6410	68 5/8" (1743)	13 1/2" (343)	5.24 (0.49)	ATA8820	96 5/8" (2454)	28 1/4" (718)	16.66 (1.55)
ATA5054	52 5/8" (1337)	64 1/16" (1637)	22.76 (2.11)	ATA6420	68 5/8" (1743)	25 1/2" (648)	10.95 (1.02)	ATA8824	96 5/8" (2454)	32 1/4" (819)	19.35 (1.80)
ATA5058	52 5/8" (1337)	68 1/16" (1738)	24.22 (2.25)	ATA6424	68 5/8" (1743)	29 1/2" (749)	12.86 (1.19)	ATA8828	96 5/8" (2454)	36 1/4" (921)	22.03 (2.05)
ATA5060	52 5/8" (1337)	72 1/16" (1840)	25.68 (2.39)	ATA6428	68 5/8" (1743)	33 1/2" (851)	14.76 (1.37)	ATA8830	96 5/8" (2454)	40 1/4" (1022)	24.71 (2.30)
ATA5064	52 5/8" (1337)	76 1/16" (1942)	27.14 (2.52)	ATA6430	68 5/8" (1743)	37 1/2" (953)	16.67 (1.55)	ATA8834	96 5/8" (2454)	44 1/4" (1124)	27.40 (2.55)
ATA5068	52 5/8" (1337)	80 1/16" (2043)	28.60 (2.66)	ATA6434	68 5/8" (1743)	41 1/2" (1054)	18.57 (1.73)	ATA8838	96 5/8" (2454)	48 1/4" (1226)	30.08 (2.79)
ATA5074	52 5/8" (1337)	88 1/16" (2246)	31.52 (2.93)	ATA6438	68 5/8" (1743)	45 1/2" (1156)	20.48 (1.90)	ATA8840	96 5/8" (2454)	52 1/4" (1327)	32.76 (3.04)
ATA5080	52 5/8" (1337)	96 1/16" (2450)	34.45 (3.20)	ATA6440	68 5/8" (1743)	49 1/2" (1257)	22.38 (2.08)	ATA8844	96 5/8" (2454)	56 1/4" (1429)	35.45 (3.29)
ATA5410	56 5/8" (1438)	11 15/16" (303)	3.90 (0.36)	ATA6444	68 5/8" (1743)	53 1/2" (1359)	24.29 (2.26)	ATA8848	96 5/8" (2454)	60 1/4" (1530)	38.13 (3.54)
ATA5420	56 5/8" (1438)	23 15/16" (608)	8.61 (0.80)	ATA6448	68 5/8" (1743)	57 1/2" (1461)	26.19 (2.43)	ATA81110	99 13/16" (2535)	17 1/16" (433)	9.27 (0.86)
ATA5424	56 5/8" (1438)	27 15/16" (710)	10.18 (0.95)	ATA6450	68 5/8" (1743)	61 1/2" (1562)	28.10 (2.61)	ATA81120	99 13/16" (2535)	29 1/16" (738)	17.59 (1.63)
ATA5428	56 5/8" (1438)	31 15/16" (811)	11.76 (1.09)	ATA6810	72 5/8" (1845)	14 1/2" (368)	5.91 (0.55)	ATA81124	99 13/16" (2535)	33 1/16" (840)	20.36 (1.89)
ATA5430	56 5/8" (1438)	35 15/16" (913)	13.33 (1.24)	ATA6820	72 5/8" (1845)	26 1/2" (673)	11.96 (1.11)	ATA81128	99 13/16" (2535)	37 1/16" (941)	23.13 (2.15)
ATA5434	56 5/8" (1438)	39 15/16" (1014)	14.90 (1.38)	ATA6824	72 5/8" (1845)	30 1/2" (775)	13.97 (1.30)	ATA81130	99 13/16" (2535)	41 1/16" (1043)	25.90 (2.41)
ATA5438	56 5/8" (1438)	43 15/16" (1116)	16.47 (1.53)	ATA6828	72 5/8" (1845)	34 1/2" (876)	15.99 (1.49)	ATA9410	104 5/8" (2657)	18 1/4" (464)	10.34 (0.96)
ATA5440	56 5/8" (1438)	47 15/16" (1218)	18.05 (1.68)	ATA6830	72 5/8" (1845)	38 1/2" (978)	18.01 (1.67)	ATA9420	104 5/8" (2657)	30 1/4" (768)	19.05 (1.77)
ATA5444	56 5/8" (1438)	51 15/16" (1319)	19.62 (1.82)	ATA6834	72 5/8" (1845)	42 1/2" (1080)	20.02 (1.86)	ATA9424	104 5/8" (2657)	34 1/4" (870)	21.96 (2.04)
ATA5448	56 5/8" (1438)	55 15/16" (1421)	21.19 (1.97)	ATA6838	72 5/8" (1845)	46 1/2" (1181)	22.04 (2.05)	ATA9428	104 5/8" (2657)	38 1/4" (972)	24.86 (2.31)
ATA5450	56 5/8" (1438)	59 15/16" (1522)	22.76 (2.11)	ATA6840	72 5/8" (1845)	50 1/2" (1283)	24.05 (2.23)	ATA9430	104 5/8" (2657)	42 1/4" (1073)	27.77 (2.58)
ATA5454	56 5/8" (1438)	63 15/16" (1624)	24.33 (2.26)	ATA6844	72 5/8" (1845)	54 1/2" (1384)	26.07 (2.42)	ATA9434	104 5/8" (2657)	46 1/4" (1175)	30.67 (2.85)
ATA5458	56 5/8" (1438)	67 15/16" (1726)	25.91 (2.41)	ATA6848	72 5/8" (1845)	58 1/2" (1486)	28.09 (2.61)	ATA9438	104 5/8" (2657)	50 1/4" (1276)	33.58 (3.12)
ATA5460	56 5/8" (1438)	71 15/16" (1827)	27.48 (2.55)	ATA6850	72 5/8" (1845)	62 1/2" (1588)	30.10 (2.80)	ATA9440	104 5/8" (2657)	54 1/4" (1378)	36.49 (3.39)
ATA5464	56 5/8" (1438)	75 15/16" (1929)	29.05 (2.70)	ATA7010	76 5/8" (1946)	15 5/8" (397)	6.64 (0.62)	ATA10010	112 5/8" (2861)	20 7/16" (519)	12.32 (1.14)
ATA5468	56 5/8" (1438)	79 15/16" (2030)	30.62 (2.84)	ATA7020	76 5/8" (1946)	27 5/8" (702)	13.03 (1.21)	ATA10020	112 5/8" (2861)	32 7/16" (824)	21.70 (2.02)
ATA5474	56 5/8" (1438)	87 15/16" (2234)	33.77 (3.14)	ATA7024	76 5/8" (1946)	31 5/8" (803)	15.15 (1.41)	ATA10024	112 5/8" (2861)	36 7/16" (926)	24.83 (2.31)
ATA5480	56 5/8" (1438)	95 15/16" (2437)	36.91 (3.43)	ATA7028	76 5/8" (1946)	35 5/8" (905)	17.28 (1.61)	ATA10028	112 5/8" (2861)	40 7/16" (1027)	27.96 (2.60)
ATA5810	60 5/8" (1540)	12 15/16" (329)	4.47 (0.42)	ATA7030	76 5/8" (1946)	39 5/8" (1006)	19.41 (1.80)	ATA10030	112 5/8" (2861)	44 7/16" (1129)	31.08 (2.89)
ATA5820	60 5/8" (1540)	24 15/16" (633)	9.52 (0.88)	ATA7034	76 5/8" (1946)	43 5/8" (1108)	21.54 (2.00)	ATA10034	112 5/8" (2861)	48 7/16" (1230)	34.21 (3.18)
ATA5824	60 5/8" (1540)	28 15/16" (735)	11.21 (1.04)	ATA7038	76 5/8" (1946)	47 5/8" (1210)	23.66 (2.20)	ATA10038	112 5/8" (2861)	52 7/16" (1332)	37.34 (3.47)
ATA5828	60 5/8" (1540)	32 15/16" (837)	12.89 (1.20)	ATA7040	76 5/8" (1946)	51 5/8" (1311)	25.79 (2.40)				

\* Dimensions in parentheses are in millimeters or square meters.

## Table of Direct-Set Springline™ Window Sizes

Scale 1/8" (3) = 1'-0" (305) – 1:96

Notes on page 95 also apply to this page.

Window Dimension	1'-7 1/4" (489)	1'-11 1/4" (591)	2'-3 1/4" (692)	2'-5 1/4" (743)	2'-7 1/4" (794)	2'-9 1/4" (845)	2'-11 1/4" (895)	3'-1 1/4" (946)	3'-3 1/4" (997)
<b>Minimum Rough Opening</b>	1'-8" (508)	2'-0" (610)	2'-4" (711)	2'-6" (762)	2'-8" (813)	2'-10" (864)	3'-0" (914)	3'-2" (965)	3'-4" (1016)
Unobstructed Glass	15 1/4" (387)	19 1/4" (489)	23 1/4" (591)	25 1/4" (641)	27 1/4" (692)	29 1/4" (743)	31 1/4" (794)	33 1/4" (845)	35 1/4" (895)

### CUSTOM SIZES AVAILABLE

Overall window height shown in table

Radius	9 5/8" (244)	11 5/8" (295)	13 5/8" (346)	14 5/8" (371)	15 5/8" (397)	16 5/8" (422)	17 5/8" (448)	18 5/8" (473)	19 5/8" (498)
--------	--------------	---------------	---------------	---------------	---------------	---------------	---------------	---------------	---------------

Chord Height	9 5/8" (244)	11 5/8" (295)	13 5/8" (346)	14 5/8" (371)	15 5/8" (397)	16 5/8" (422)	17 5/8" (448)	18 5/8" (473)	19 5/8" (498)
--------------	--------------	---------------	---------------	---------------	---------------	---------------	---------------	---------------	---------------

Side Height	6 1/4" (159) ATSD1807	1'-5 7/8" (454) ATSD2007	1'-7 7/8" (505) ATSD2407	1'-8 7/8" (530) ATSD2607	1'-9 7/8" (556) ATSD2807	1'-10 7/8" (581) ATSD21007	1'-11 7/8" (606) ATSD3007	2'-0 7/8" (632) ATSD3207	2'-1 7/8" (657) ATSD3407
-------------	--------------------------	-----------------------------	-----------------------------	-----------------------------	-----------------------------	-------------------------------	------------------------------	-----------------------------	-----------------------------

Side Height	11 1/4" (286) ATSD1810	1'-8 7/8" (581) ATSD2010	2'-0 7/8" (632) ATSD2410	2'-1 7/8" (657) ATSD2610	2'-2 7/8" (683) ATSD2810	2'-3 7/8" (708) ATSD21010	2'-4 7/8" (733) ATSD3010	2'-5 7/8" (759) ATSD3210	2'-6 7/8" (784) ATSD3410
-------------	---------------------------	-----------------------------	-----------------------------	-----------------------------	-----------------------------	------------------------------	-----------------------------	-----------------------------	-----------------------------

Side Height	23 1/4" (591) ATSD1820	2'-10 7/8" (886) ATSD2020	3'-0 7/8" (937) ATSD2420	3'-1 7/8" (962) ATSD2620	3'-2 7/8" (987) ATSD2820	3'-3 7/8" (1013) ATSD21020	3'-4 7/8" (1038) ATSD3020	3'-5 7/8" (1064) ATSD3220	3'-6 7/8" (1089) ATSD3420
-------------	---------------------------	------------------------------	-----------------------------	-----------------------------	-----------------------------	-------------------------------	------------------------------	------------------------------	------------------------------

Side Height	27 1/4" (692) ATSD1824	3'-2 7/8" (987) ATSD2024	3'-4 7/8" (1038) ATSD2424	3'-5 7/8" (1064) ATSD2624	3'-6 7/8" (1089) ATSD2824	3'-7 7/8" (1114) ATSD21024	3'-8 7/8" (1140) ATSD3024	3'-9 7/8" (1166) ATSD3224	3'-10 7/8" (1191) ATSD3424
-------------	---------------------------	-----------------------------	------------------------------	------------------------------	------------------------------	-------------------------------	------------------------------	------------------------------	-------------------------------

Side Height	31 1/4" (794) ATSD1828	3'-6 7/8" (1089) ATSD2028	3'-8 7/8" (1140) ATSD2428	3'-9 7/8" (1165) ATSD2628	3'-10 7/8" (1191) ATSD2828	3'-11 7/8" (1216) ATSD21028	4'-0 7/8" (1241) ATSD3028	4'-1 7/8" (1267) ATSD3228	4'-2 7/8" (1292) ATSD3428
-------------	---------------------------	------------------------------	------------------------------	------------------------------	-------------------------------	--------------------------------	------------------------------	------------------------------	------------------------------

Side Height	35 1/4" (895) ATSD1830	3'-10 7/8" (1191) ATSD2030	4'-0 7/8" (1241) ATSD2430	4'-1 7/8" (1267) ATSD2630	4'-2 7/8" (1292) ATSD2830	4'-3 7/8" (1318) ATSD21030	4'-4 7/8" (1343) ATSD3030	4'-5 7/8" (1368) ATSD3230	4'-6 7/8" (1394) ATSD3430
-------------	---------------------------	-------------------------------	------------------------------	------------------------------	------------------------------	-------------------------------	------------------------------	------------------------------	------------------------------

Side Height	39 1/4" (997) ATSD1834	4'-2 7/8" (1292) ATSD2034	4'-4 7/8" (1343) ATSD2434	4'-5 7/8" (1368) ATSD2634	4'-6 7/8" (1394) ATSD2834	4'-7 7/8" (1419) ATSD21034	4'-8 7/8" (1445) ATSD3034	4'-9 7/8" (1470) ATSD3234	4'-10 7/8" (1495) ATSD3434*
-------------	---------------------------	------------------------------	------------------------------	------------------------------	------------------------------	-------------------------------	------------------------------	------------------------------	--------------------------------

Side Height	43 1/4" (1099) ATSD1838	4'-6 7/8" (1394) ATSD2038	4'-8 7/8" (1445) ATSD2438	4'-9 7/8" (1470) ATSD2638	4'-10 7/8" (1495) ATSD2838	4'-11 7/8" (1521) ATSD21038	5'-0 7/8" (1546) ATSD3038	5'-1 7/8" (1572) ATSD3238*	5'-2 7/8" (1597) ATSD3438*
-------------	----------------------------	------------------------------	------------------------------	------------------------------	-------------------------------	--------------------------------	------------------------------	-------------------------------	-------------------------------

**Minimum Rough Opening = overall window height + 3/4" (19)**  
 Unobstructed Glass = window height - 4" (102)

\* "Window Dimension" always refers to outside frame to frame dimension.  
 \* "Minimum Rough Opening" dimensions may need to be increased to allow for use of building wraps, flashing, sill panning, brackets, fasteners or other items. See installation information on page 170.  
 \* Dimensions in parentheses are in millimeters.  
 \* Tempered laminated glass required. Some visual distortion may occur.

Notes on page 95 also apply to this page. Springline™ sizes on pages 90-96.

3'-7 1/4" (1099)	3'-11 1/4" (1200)	4'-3 1/4" (1302)	4'-7 1/4" (1403)	4'-11 1/4" (1505)	5'-3 1/4" (1607)	5'-7 1/4" (1708)	5'-11 1/4" (1810)
3'-8" (1118)	4'-0" (1219)	4'-4" (1321)	4'-8" (1422)	5'-0" (1524)	5'-4" (1626)	5'-8" (1727)	6'-0" (1829)
39 1/4" (997)	43 1/4" (1099)	47 1/4" (1200)	51 1/4" (1302)	55 1/4" (1403)	59 1/4" (1505)	63 1/4" (1607)	67 1/4" (1708)
21 5/8" (549)	23 5/8" (600)	25 5/8" (651)	27 5/8" (702)	29 5/8" (752)	31 5/8" (803)	33 5/8" (854)	35 5/8" (905)
21 5/8" (549)	23 5/8" (600)	25 5/8" (651)	27 5/8" (702)	29 5/8" (752)	31 5/8" (803)	33 5/8" (854)	35 5/8" (905)
2'-3 7/8" (708)	2'-5 7/8" (759)	2'-7 7/8" (810)	2'-9 7/8" (860)	2'-11 7/8" (911)	3'-1 7/8" (962)	3'-3 7/8" (1013)	3'-5 7/8" (1064)
ATSD3807	ATSD4007	ATSD4407	ATSD4807	ATSD5007	ATSD5407*	ATSD5807*	ATSD6007*
2'-8 7/8" (835)	2'-10 7/8" (886)	3'-0 7/8" (937)	3'-2 7/8" (987)	3'-4 7/8" (1038)	3'-6 7/8" (1089)	3'-8 7/8" (1140)	3'-10 7/8" (1191)
ATSD3810	ATSD4010	ATSD4410	ATSD4810	ATSD5010*	ATSD5410*	ATSD5810*	ATSD6010*
3'-8 7/8" (1140)	3'-10 7/8" (1191)	4'-0 7/8" (1241)	4'-2 7/8" (1292)	4'-4 7/8" (1343)	4'-6 7/8" (1394)	4'-8 7/8" (1445)	4'-10 7/8" (1495)
ATSD3820	ATSD4020	ATSD4420*	ATSD4820*	ATSD5020*	ATSD5420*	ATSD5820*	ATSD6020*
4'-0 7/8" (1241)	4'-2 7/8" (1292)	4'-4 7/8" (1343)	4'-6 7/8" (1394)	4'-8 7/8" (1445)	4'-10 7/8" (1495)	5'-0 7/8" (1546)	5'-2 7/8" (1597)
ATSD3824	ATSD4024*	ATSD4424*	ATSD4824*	ATSD5024*	ATSD5424*	ATSD5824*	ATSD6024*
4'-4 7/8" (1343)	4'-6 7/8" (1394)	4'-8 7/8" (1445)	4'-10 7/8" (1495)	5'-0 7/8" (1546)	5'-2 7/8" (1597)	5'-4 7/8" (1648)	5'-6 7/8" (1699)
ATSD3828*	ATSD4028*	ATSD4428*	ATSD4828*	ATSD5028*	ATSD5428*	ATSD5828*	ATSD6028*
4'-8 7/8" (1445)	4'-10 7/8" (1495)	5'-0 7/8" (1546)	5'-2 7/8" (1597)	5'-4 7/8" (1648)	5'-6 7/8" (1699)	5'-8 7/8" (1749)	5'-10 7/8" (1800)
ATSD3830*	ATSD4030*	ATSD4430*	ATSD4830*	ATSD5030*	ATSD5430*	ATSD5830*	ATSD6030*
5'-0 7/8" (1546)	5'-2 7/8" (1597)	5'-4 7/8" (1648)	5'-6 7/8" (1699)	5'-8 7/8" (1749)	5'-10 7/8" (1800)	6'-0 7/8" (1851)	6'-2 7/8" (1902)
ATSD3834*	ATSD4034*	ATSD4434*	ATSD4834*	ATSD5034*	ATSD5434*	ATSD5834*	ATSD6034*
5'-4 7/8" (1648)	5'-6 7/8" (1699)	5'-8 7/8" (1749)	5'-10 7/8" (1800)	6'-0 7/8" (1851)	6'-2 7/8" (1902)	6'-4 7/8" (1953)	6'-6 7/8" (2003)
ATSD3838*	ATSD4038*	ATSD4438*	ATSD4838*	ATSD5038*	ATSD5438*	ATSD5838*	ATSD6038*

\*Window Dimension\* always refers to outside frame to frame dimension.  
**\*\*Minimum Rough Opening\*\* dimensions may need to be increased to allow for use of building wraps, flashing, sill panning, brackets, fasteners or other items. See installation information on page 170.**  
 \*Dimensions in parentheses are in millimeters.  
 \*Tempered laminated glass required. Some visual distortion may occur.  
 †Heat strengthened laminated glass required. Some visual distortion may occur.

continued on next page

**Table of Direct-Set Springline™ Window Sizes** (continued)

Notes on page 95 also apply to this page.

Scale 1/8" (3) = 1'-0" (305) – 1:96

Window Dimension	1'-7 1/4" (489)	1'-11 1/4" (591)	2'-3 1/4" (692)	2'-5 1/4" (743)	2'-7 1/4" (794)	2'-9 1/4" (845)	2'-11 1/4" (895)	3'-1 1/4" (946)	3'-3 1/4" (997)
<b>Minimum Rough Opening</b>	1'-8" (508)	2'-0" (610)	2'-4" (711)	2'-6" (762)	2'-8" (813)	2'-10" (864)	3'-0" (914)	3'-2" (965)	3'-4" (1016)
Unobstructed Glass	15 1/4" (387)	19 1/4" (489)	23 1/4" (591)	25 1/4" (641)	27 1/4" (692)	29 1/4" (743)	31 1/4" (794)	33 1/4" (845)	35 1/4" (895)

**CUSTOM SIZES AVAILABLE**

Overall window height shown in table

Radius	9 5/8" (244)	11 5/8" (295)	13 5/8" (346)	14 5/8" (371)	15 5/8" (397)	16 5/8" (422)	17 5/8" (448)	18 5/8" (473)	19 5/8" (498)
--------	--------------	---------------	---------------	---------------	---------------	---------------	---------------	---------------	---------------

Chord Height	9 5/8" (244)	11 5/8" (295)	13 5/8" (346)	14 5/8" (371)	15 5/8" (397)	16 5/8" (422)	17 5/8" (448)	18 5/8" (473)	19 5/8" (498)
--------------	--------------	---------------	---------------	---------------	---------------	---------------	---------------	---------------	---------------

**CUSTOM SIZES AVAILABLE**

Side Height

Unobstructed Glass = window height - 4" (102)

Minimum Rough Opening = overall window height + 3/4" (19)

\*"Window Dimension" always refers to outside frame to frame dimension.  
 \*"**Minimum Rough Opening**" dimensions may need to be increased to allow for use of building wraps, flashing, sill panning, brackets, fasteners or other items. See installation information on page 170.  
 \*Dimensions in parentheses are in millimeters.  
 \*Tempered laminated glass required. Some visual distortion may occur.

Notes on page 95 also apply to this page. Springline™ sizes on pages 90-96.

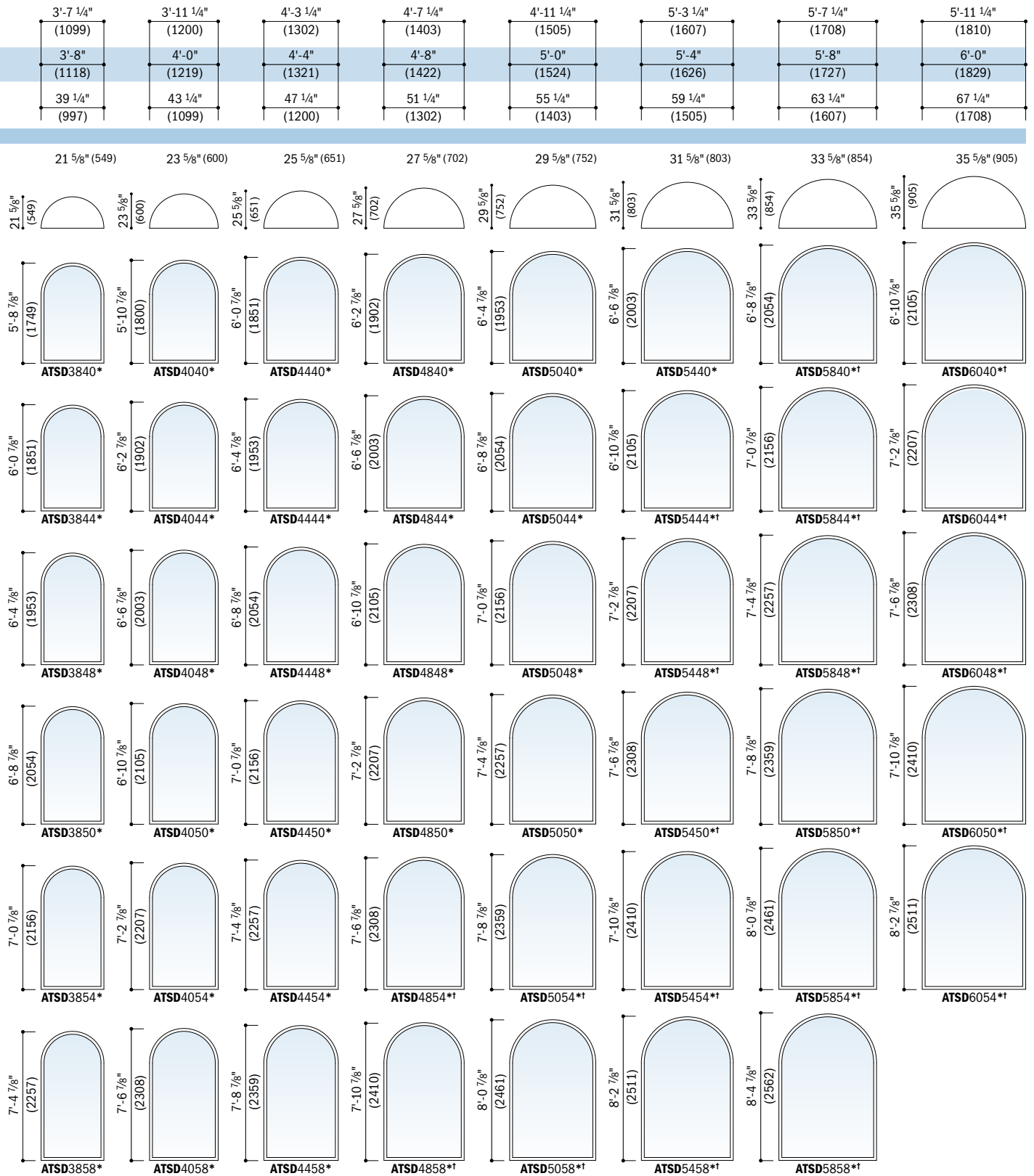

continued on next page

\*Window Dimension™ always refers to outside frame to frame dimension.  
 \*\*Minimum Rough Opening™ dimensions may need to be increased to allow for use of building wraps, flashing, sill panning, brackets, fasteners or other items. See installation information on page 170.  
 †Dimensions in parentheses are in millimeters.  
 \*Tempered laminated glass required. Some visual distortion may occur.  
 †Heat strengthened laminated glass required. Some visual distortion may occur.

**Table of Direct-Set Springline™ Window Sizes** (continued)

Notes on the next page also apply to this page.

Scale 1/8" (3) = 1'-0" (305) – 1:96

Window Dimension	1'-7 1/4" (489)	1'-11 1/4" (591)	2'-3 1/4" (692)	2'-5 1/4" (743)	2'-7 1/4" (794)	2'-9 1/4" (845)	2'-11 1/4" (895)	3'-1 1/4" (946)	3'-3 1/4" (997)
<b>Minimum Rough Opening</b>	1'-8" (508)	2'-0" (610)	2'-4" (711)	2'-6" (762)	2'-8" (813)	2'-10" (864)	3'-0" (914)	3'-2" (965)	3'-4" (1016)
Unobstructed Glass	15 1/4" (387)	19 1/4" (489)	23 1/4" (591)	25 1/4" (641)	27 1/4" (692)	29 1/4" (743)	31 1/4" (794)	33 1/4" (845)	35 1/4" (895)

**CUSTOM SIZES AVAILABLE**

**Minimum Rough Opening = overall window height + 3/4" (19)**  
 Unobstructed Glass = window height - 4" (102)

Overall window height shown in table	Radius	9 5/8" (244)	11 5/8" (295)	13 5/8" (346)	14 5/8" (371)	15 5/8" (397)	16 5/8" (422)	17 5/8" (448)	18 5/8" (473)	19 5/8" (498)
Chord Height		9 5/8" (244)	11 5/8" (295)	13 5/8" (346)	14 5/8" (371)	15 5/8" (397)	16 5/8" (422)	17 5/8" (448)	18 5/8" (473)	19 5/8" (498)
Side Height	71 1/4" (1810)	6'-8 7/8" (2054)	6'-10 7/8" (2105)	7'-0 7/8" (2156)	7'-1 7/8" (2181)	7'-2 7/8" (2207)	7'-3 7/8" (2232)	7'-4 7/8" (2257)	7'-5 7/8" (2283)	7'-6 7/8" (2308)
		ATSD1860	ATSD2060	ATSD2460*	ATSD2660*	ATSD2860*	ATSD21060*	ATSD3060*	ATSD3260*	ATSD3460*
	75 1/4" (1911)	7'-0 7/8" (2156)	7'-2 7/8" (2207)	7'-4 7/8" (2257)	7'-5 7/8" (2283)	7'-6 7/8" (2308)	7'-7 7/8" (2334)	7'-8 7/8" (2359)	7'-9 7/8" (2384)	7'-10 7/8" (2410)
		ATSD1864	ATSD2064	ATSD2464*	ATSD2664*	ATSD2864*	ATSD21064*	ATSD3064*	ATSD3264*	ATSD3464*
	79 1/4" (2013)	7'-4 7/8" (2257)	7'-6 7/8" (2308)	7'-8 7/8" (2359)	7'-9 7/8" (2384)	7'-10 7/8" (2410)	7'-11 7/8" (2435)	8'-0 7/8" (2461)	8'-1 7/8" (2486)	8'-2 7/8" (2511)
		ATSD1868	ATSD2068	ATSD2468*	ATSD2668*	ATSD2868*	ATSD21068*	ATSD3068*	ATSD3268*	ATSD3468*
	87 1/4" (2216)	8'-0 7/8" (2461)	8'-2 7/8" (2511)	8'-4 7/8" (2562)	8'-5 7/8" (2588)	8'-6 7/8" (2613)	8'-7 7/8" (2638)	8'-8 7/8" (2664)	8'-9 7/8" (2689)	8'-10 7/8" (2715)
		ATSD1874	ATSD2074*	ATSD2474*	ATSD2674*	ATSD2874*	ATSD21074*	ATSD3074*	ATSD3274*	ATSD3474*
	95 1/4" (2419)	8'-8 7/8" (2664)	8'-10 7/8" (2715)	9'-0 7/8" (2765)	9'-1 7/8" (2791)	9'-2 7/8" (2816)	9'-3 7/8" (2842)	9'-4 7/8" (2867)	9'-5 7/8" (2892)	9'-6 7/8" (2918)
		ATSD1880	ATSD2080*	ATSD2480*	ATSD2680*	ATSD2880*	ATSD21080*	ATSD3080*	ATSD3280*	ATSD3480*

\* "Window Dimension" always refers to outside frame to frame dimension.  
 \* "Minimum Rough Opening" dimensions may need to be increased to allow for use of building wraps, flashing, sill panning, brackets, fasteners or other items. See installation information on page 170.  
 \* Dimensions in parentheses are in millimeters.  
 \* Tempered laminated glass required. Some visual distortion may occur.



**Springline™ sizes on pages 90-96.**

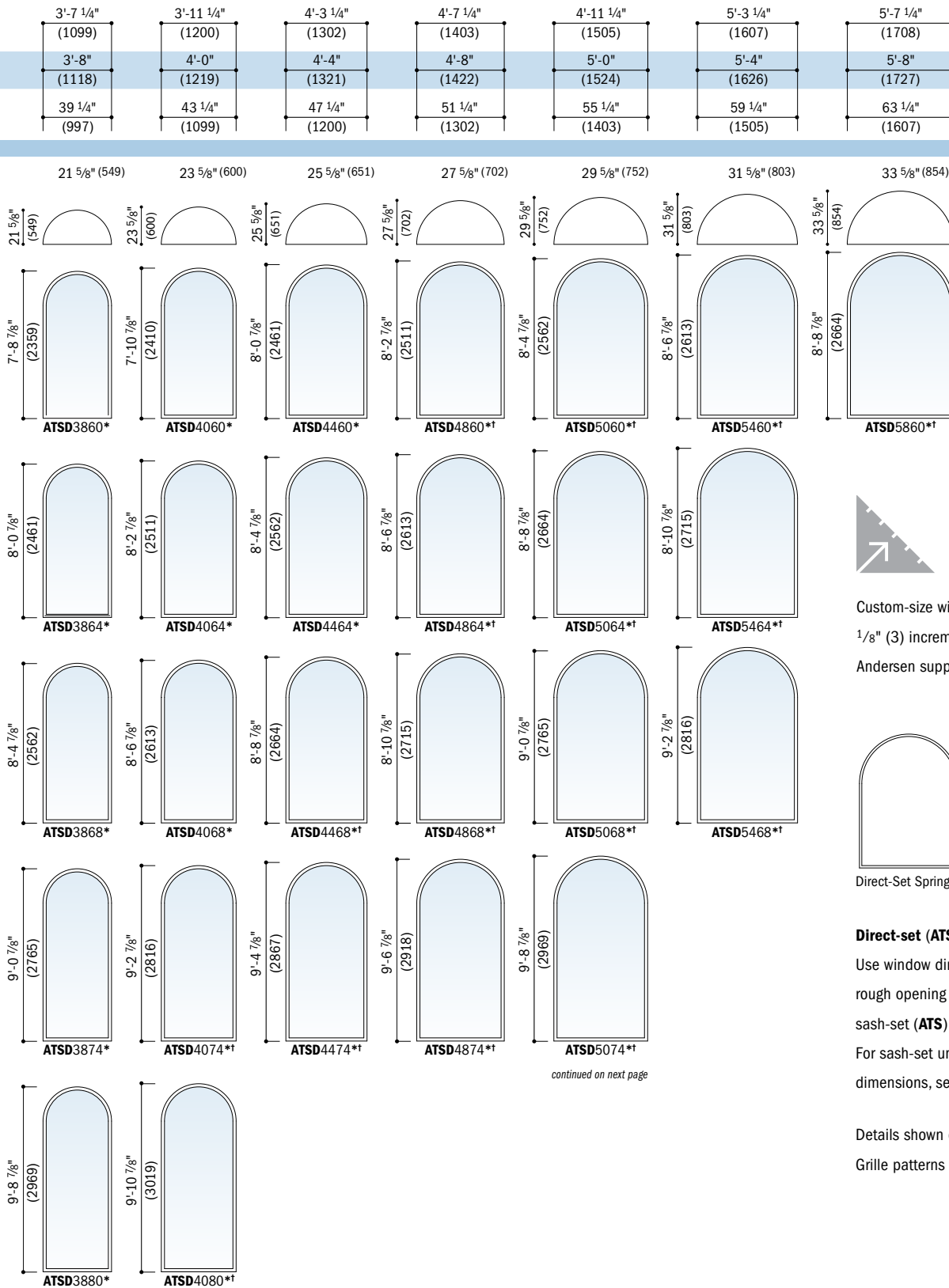

Custom-size windows are available in 1/8" (3) increments. Contact your Andersen supplier for more information.

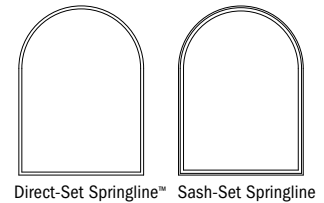

**Direct-set (ATSD) window sizes shown.**

Use window dimensions and minimum rough opening formula shown for sash-set (ATS) window sizes.

For sash-set unobstructed glass dimensions, see page 99.

Details shown on page 101.

Grille patterns shown on page 97.

\*"Window Dimension" always refers to outside frame to frame dimension.  
 \*\*"Minimum Rough Opening" dimensions may need to be increased to allow for use of building wraps, flashing, sill panning, brackets, fasteners or other items. See installation information on page 170.  
 †Dimensions in parentheses are in millimeters.  
 \*Tempered laminated glass required. Some visual distortion may occur.  
 †Heat strengthened laminated glass required. Some visual distortion may occur.

*continued on next page*

**Table of Direct-Set Springline™ Window Sizes** (continued)

Springline™ sizes on pages 90-96.

Scale 1/8" (3) = 1'-0" (305) – 1:96

Window Dimension	6'-3 1/4" (1911)	6'-7 1/4" (2013)	6'-11 1/4" (2115)	7'-3 1/4" (2216)	7'-11 1/4" (2419)
<b>Minimum Rough Opening</b>	6'-4" (1930)	6'-8" (2032)	7'-0" (2134)	7'-4" (2235)	8'-0" (2438)
Unobstructed Glass	71 1/4" (1810)	75 1/4" (1911)	79 1/4" (2013)	83 1/4" (2115)	91 1/4" (2318)

CUSTOM SIZES AVAILABLE						
Overall window height shown in table	Radius	37 5/8" (956)	39 5/8" (1006)	41 5/8" (1057)	43 5/8" (1108)	47 5/8" (1210)
	Chord Height	37 5/8" (956)	39 5/8" (1006)	41 5/8" (1057)	43 5/8" (1108)	47 5/8" (1210)
<b>Minimum Rough Opening = overall window height + 3/4" (19)</b> Unobstructed Glass = window height - 4" (102)	Side Height	6 1/4" (159)	3-9 7/8" (1116)	3-11 7/8" (1216)	4'-1 7/8" (1267)	4'-5 7/8" (1368)
		ATSD6407*	ATSD6807*	ATSD7007*	ATSD7407*	ATSD8007*
	11 1/4" (286)	4'-0 7/8" (1241)	4'-2 7/8" (1292)	4'-4 7/8" (1343)	4'-6 7/8" (1394)	4'-10 7/8" (1495)
		ATSD6410*	ATSD6810*	ATSD7010*	ATSD7410*	ATSD8010*†
	23 1/4" (591)	5'-0 7/8" (1546)	5'-2 7/8" (1597)	5'-4 7/8" (1648)	5'-6 7/8" (1699)	5'-10 7/8" (1800)
		ATSD6420*	ATSD6820*	ATSD7020*†	ATSD7420*†	ATSD8020*†
	27 1/4" (692)	5'-4 7/8" (1648)	5'-6 7/8" (1699)	5'-8 7/8" (1749)	5'-10 7/8" (1800)	
	ATSD6424*	ATSD6824*†	ATSD7024*†	ATSD7424*†		
31 1/4" (794)	5'-8 7/8" (1749)	5'-10 7/8" (1800)				
	ATSD6428*†	ATSD6828*†				



Custom-size windows are available in 1/8" (3) increments. Contact your Andersen supplier for more information.

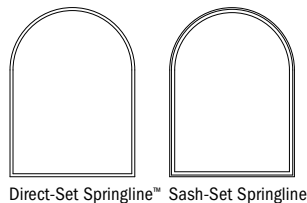

**Direct-set (ATSD) window sizes shown.** Use window dimensions and minimum rough opening formula shown for sash-set (ATS) window sizes. For sash-set unobstructed glass dimensions, see page 99.

Details shown on page 101. Grille patterns shown on page 97.

\* "Window Dimension" always refers to outside frame to frame dimension.  
 • "Minimum Rough Opening" dimensions may need to be increased to allow for use of building wraps, flashing, sill panning, brackets, fasteners or other items. See installation information on page 170.  
 • Dimensions in parentheses are in millimeters.  
 \* Tempered laminated glass required. Some visual distortion may occur.  
 † Heat strengthened laminated glass required. Some visual distortion may occur.

Grille Patterns

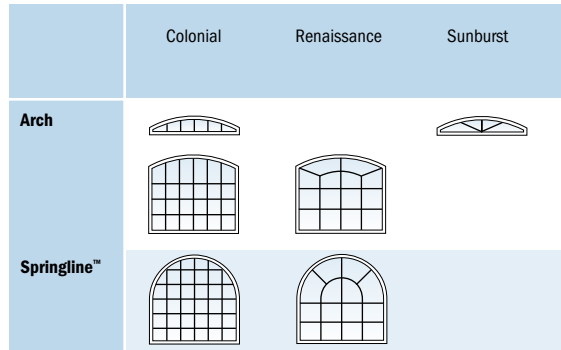

Number of lights and overall pattern varies with window size. Patterns are not available in all configurations. Specified equal light and custom patterns are also available. For more information on divided light, see page 15 or visit [andersenwindows.com/grilles](http://andersenwindows.com/grilles).

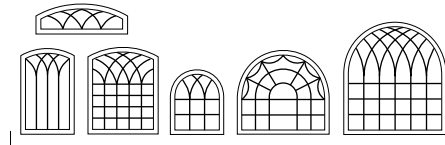

Custom Pattern Examples

Direct-Set Springline™  
Window Area Specifications

Window Number	Glass Area Sq. Ft./ (m <sup>2</sup> )	Window Number	Glass Area Sq. Ft./ (m <sup>2</sup> )	Window Number	Glass Area Sq. Ft./ (m <sup>2</sup> )	Window Number	Glass Area Sq. Ft./ (m <sup>2</sup> )
ATSD1807	1.08 (0.10)	ATSD2410	2.97 (0.28)	ATSD2820	6.05 (0.56)	ATSD3024	8.14 (0.76)
ATSD1810	1.61 (0.15)	ATSD2420	4.91 (0.46)	ATSD2824	6.80 (0.63)	ATSD3028	9.01 (0.84)
ATSD1820	2.88 (0.27)	ATSD2424	5.55 (0.52)	ATSD2828	7.56 (0.70)	ATSD3030	9.88 (0.92)
ATSD1824	3.31 (0.31)	ATSD2428	6.20 (0.58)	ATSD2830	8.32 (0.77)	ATSD3034	10.75 (1.00)
ATSD1828	3.73 (0.35)	ATSD2430	6.84 (0.64)	ATSD2834	9.07 (0.84)	ATSD3038	11.61 (1.08)
ATSD1830	4.16 (0.39)	ATSD2434	7.49 (0.70)	ATSD2838	9.83 (0.91)	ATSD3040	12.48 (1.16)
ATSD1834	4.58 (0.43)	ATSD2438	8.13 (0.76)	ATSD2840	10.59 (0.98)	ATSD3044	13.35 (1.24)
ATSD1838	5.00 (0.46)	ATSD2440	8.78 (0.82)	ATSD2844	11.34 (1.05)	ATSD3048	14.22 (1.32)
ATSD1840	5.43 (0.50)	ATSD2444	9.43 (0.88)	ATSD2848	12.10 (1.12)	ATSD3050	15.09 (1.40)
ATSD1844	5.85 (0.54)	ATSD2448	10.07 (0.94)	ATSD2850	12.86 (1.19)	ATSD3054	15.96 (1.48)
ATSD1848	6.27 (0.58)	ATSD2450	10.72 (1.00)	ATSD2854	13.62 (1.27)	ATSD3058	16.82 (1.56)
ATSD1850	6.70 (0.62)	ATSD2454	11.36 (1.06)	ATSD2858	14.37 (1.34)	ATSD3060	17.69 (1.64)
ATSD1854	7.12 (0.66)	ATSD2458	12.01 (1.12)	ATSD2860	15.13 (1.41)	ATSD3064	18.56 (1.72)
ATSD1858	7.54 (0.70)	ATSD2460	12.66 (1.18)	ATSD2864	15.89 (1.48)	ATSD3068	19.43 (1.81)
ATSD1860	7.97 (0.74)	ATSD2464	13.30 (1.24)	ATSD2868	16.64 (1.55)	ATSD3074	21.16 (1.97)
ATSD1864	8.39 (0.78)	ATSD2468	13.95 (1.30)	ATSD2874	18.16 (1.69)	ATSD3080	22.90 (2.13)
ATSD1868	8.82 (0.82)	ATSD2474	15.24 (1.42)	ATSD2880	19.67 (1.83)	ATSD3207	4.00 (0.37)
ATSD1874	9.66 (0.90)	ATSD2480	16.53 (1.54)	ATSD21007	3.20 (0.30)	ATSD3210	5.15 (0.48)
ATSD1880	10.51 (0.98)	ATSD2607	2.48 (0.23)	ATSD21010	4.21 (0.39)	ATSD3220	7.92 (0.74)
ATSD2007	1.58 (0.15)	ATSD2610	3.36 (0.31)	ATSD21020	6.65 (0.62)	ATSD3224	8.85 (0.82)
ATSD2010	2.25 (0.21)	ATSD2620	5.46 (0.51)	ATSD21024	7.46 (0.69)	ATSD3228	9.77 (0.91)
ATSD2020	3.85 (0.36)	ATSD2624	6.17 (0.57)	ATSD21028	8.27 (0.77)	ATSD3230	10.69 (0.99)
ATSD2024	4.39 (0.41)	ATSD2628	6.87 (0.64)	ATSD21030	9.09 (0.84)	ATSD3234	11.62 (1.08)
ATSD2028	4.92 (0.46)	ATSD2630	7.57 (0.70)	ATSD21034	9.90 (0.92)	ATSD3238	12.54 (1.17)
ATSD2030	5.46 (0.51)	ATSD2634	8.27 (0.77)	ATSD21038	10.71 (0.99)	ATSD3240	13.46 (1.25)
ATSD2034	5.99 (0.56)	ATSD2638	8.97 (0.83)	ATSD21040	11.52 (1.07)	ATSD3244	14.39 (1.34)
ATSD2038	6.52 (0.61)	ATSD2640	9.67 (0.90)	ATSD21044	12.34 (1.15)	ATSD3248	15.31 (1.42)
ATSD2040	7.06 (0.66)	ATSD2644	10.37 (0.96)	ATSD21048	13.15 (1.22)	ATSD3250	16.23 (1.51)
ATSD2044	7.59 (0.71)	ATSD2648	11.08 (1.03)	ATSD21050	13.96 (1.30)	ATSD3254	17.16 (1.59)
ATSD2048	8.13 (0.76)	ATSD2650	11.78 (1.09)	ATSD21054	14.77 (1.37)	ATSD3258	18.08 (1.68)
ATSD2050	8.66 (0.80)	ATSD2654	12.48 (1.16)	ATSD21058	15.59 (1.45)	ATSD3260	19.00 (1.77)
ATSD2054	9.20 (0.85)	ATSD2658	13.18 (1.22)	ATSD21060	16.40 (1.52)	ATSD3264	19.93 (1.85)
ATSD2058	9.73 (0.90)	ATSD2660	13.88 (1.29)	ATSD21064	17.21 (1.60)	ATSD3268	20.85 (1.94)
ATSD2060	10.27 (0.95)	ATSD2664	14.58 (1.35)	ATSD21068	18.02 (1.67)	ATSD3274	22.70 (2.11)
ATSD2064	10.80 (1.00)	ATSD2668	15.28 (1.42)	ATSD21074	19.65 (1.83)	ATSD3280	24.55 (2.28)
ATSD2068	11.34 (1.05)	ATSD2674	16.69 (1.55)	ATSD21080	21.27 (1.98)	ATSD3407	4.43 (0.41)
ATSD2074	12.41 (1.15)	ATSD2680	18.09 (1.68)	ATSD3007	3.59 (0.33)	ATSD3410	5.65 (0.52)
ATSD2080	13.48 (1.25)	ATSD2807	2.83 (0.26)	ATSD3010	4.67 (0.43)		
ATSD2407	2.16 (0.20)	ATSD2810	3.78 (0.35)	ATSD3020	7.27 (0.68)		

\* Dimensions in parentheses are in square meters.

continued on next page

## Direct-Set Springline™ Window Area Specifications (continued)

Window Number	Glass Area Sq. Ft./ (m <sup>2</sup> )	Window Number	Glass Area Sq. Ft./ (m <sup>2</sup> )	Window Number	Glass Area Sq. Ft./ (m <sup>2</sup> )
ATSD3420	8.59 (0.80)	ATSD4430	17.00 (1.58)	ATSD5450	33.13 (3.08)
ATSD3424	9.57 (0.89)	ATSD4434	18.31 (1.70)	ATSD5454	34.78 (3.23)
ATSD3428	10.55 (0.98)	ATSD4438	19.62 (1.82)	ATSD5458	36.42 (3.38)
ATSD3430	11.53 (1.07)	ATSD4440	20.94 (1.95)	ATSD5460	38.07 (3.54)
ATSD3434	12.51 (1.16)	ATSD4444	22.25 (2.07)	ATSD5464	39.71 (3.69)
ATSD3438	13.49 (1.25)	ATSD4448	23.56 (2.19)	ATSD5468	41.36 (3.84)
ATSD3440	14.47 (1.34)	ATSD4450	24.87 (2.31)	ATSD5807	12.78 (1.19)
ATSD3444	15.44 (1.43)	ATSD4454	26.19 (2.43)	ATSD5810	14.97 (1.39)
ATSD3448	16.42 (1.53)	ATSD4458	27.50 (2.55)	ATSD5820	20.24 (1.88)
ATSD3450	17.40 (1.62)	ATSD4460	28.81 (2.68)	ATSD5824	22.00 (2.04)
ATSD3454	18.38 (1.71)	ATSD4464	30.12 (2.80)	ATSD5828	23.76 (2.21)
ATSD3458	19.36 (1.80)	ATSD4468	31.44 (2.92)	ATSD5830	25.51 (2.37)
ATSD3460	20.34 (1.89)	ATSD4474	34.06 (3.16)	ATSD5834	27.27 (2.53)
ATSD3464	21.32 (1.98)	ATSD4807	8.68 (0.81)	ATSD5838	29.03 (2.70)
ATSD3468	22.30 (2.07)	ATSD4810	10.45 (0.97)	ATSD5840	30.79 (2.86)
ATSD3474	24.26 (2.25)	ATSD4820	14.73 (1.37)	ATSD5844	32.54 (3.02)
ATSD3480	26.22 (2.44)	ATSD4824	16.15 (1.50)	ATSD5848	34.30 (3.19)
ATSD3807	5.36 (0.50)	ATSD4828	17.57 (1.63)	ATSD5850	36.06 (3.35)
ATSD3810	6.72 (0.62)	ATSD4830	19.00 (1.77)	ATSD5854	37.81 (3.51)
ATSD3820	9.99 (0.93)	ATSD4834	20.42 (1.90)	ATSD5858	39.57 (3.68)
ATSD3824	11.08 (1.03)	ATSD4838	21.84 (2.03)	ATSD5860	41.33 (3.84)
ATSD3828	12.17 (1.13)	ATSD4840	23.27 (2.16)	ATSD6007	14.32 (1.33)
ATSD3830	13.26 (1.23)	ATSD4844	24.69 (2.29)	ATSD6010	16.65 (1.55)
ATSD3834	14.35 (1.33)	ATSD4848	26.11 (2.43)	ATSD6020	22.26 (2.07)
ATSD3838	15.44 (1.43)	ATSD4850	27.54 (2.56)	ATSD6024	24.13 (2.24)
ATSD3840	16.53 (1.54)	ATSD4854	28.96 (2.69)	ATSD6028	25.99 (2.41)
ATSD3844	17.63 (1.64)	ATSD4858	30.39 (2.82)	ATSD6030	27.86 (2.59)
ATSD3848	18.72 (1.74)	ATSD4860	31.81 (2.96)	ATSD6034	29.73 (2.76)
ATSD3850	19.81 (1.84)	ATSD4864	33.23 (3.09)	ATSD6038	31.60 (2.94)
ATSD3854	20.90 (1.94)	ATSD4868	34.66 (3.22)	ATSD6040	33.47 (3.11)
ATSD3858	21.99 (2.04)	ATSD4874	37.50 (3.48)	ATSD6044	35.33 (3.28)
ATSD3860	23.08 (2.14)	ATSD5007	9.96 (0.93)	ATSD6048	37.20 (3.46)
ATSD3864	24.17 (2.25)	ATSD5010	11.87 (1.10)	ATSD6050	39.07 (3.63)
ATSD3868	25.26 (2.35)	ATSD5020	16.48 (1.53)	ATSD6054	40.94 (3.80)
ATSD3874	27.44 (2.55)	ATSD5024	18.01 (1.67)	ATSD6407	15.95 (1.48)
ATSD3880	29.62 (2.75)	ATSD5028	19.55 (1.82)	ATSD6410	18.42 (1.71)
ATSD4007	6.38 (0.59)	ATSD5030	21.08 (1.96)	ATSD6420	24.36 (2.26)
ATSD4010	7.88 (0.73)	ATSD5034	22.62 (2.10)	ATSD6424	26.34 (2.45)
ATSD4020	11.48 (1.07)	ATSD5038	24.15 (2.24)	ATSD6428	28.32 (2.63)
ATSD4024	12.68 (1.18)	ATSD5040	25.69 (2.39)	ATSD6807	17.66 (1.64)
ATSD4028	13.89 (1.29)	ATSD5044	27.22 (2.53)	ATSD6810	20.28 (1.88)
ATSD4030	15.09 (1.40)	ATSD5048	28.76 (2.67)	ATSD6820	26.55 (2.47)
ATSD4034	16.29 (1.51)	ATSD5050	30.29 (2.81)	ATSD6824	28.64 (2.66)
ATSD4038	17.49 (1.62)	ATSD5054	31.83 (2.96)	ATSD6828	30.73 (2.85)
ATSD4040	18.69 (1.74)	ATSD5058	33.36 (3.10)	ATSD7007	19.47 (1.81)
ATSD4044	19.89 (1.85)	ATSD5060	34.89 (3.24)	ATSD7010	22.22 (2.06)
ATSD4048	21.09 (1.96)	ATSD5064	36.43 (3.38)	ATSD7020	28.82 (2.68)
ATSD4050	22.30 (2.07)	ATSD5068	37.96 (3.53)	ATSD7024	31.02 (2.88)
ATSD4054	23.50 (2.18)	ATSD5074	41.03 (3.81)	ATSD7407	21.36 (1.98)
ATSD4058	24.70 (2.29)	ATSD5407	11.32 (1.05)	ATSD7410	24.25 (2.25)
ATSD4060	25.90 (2.41)	ATSD5410	13.38 (1.24)	ATSD7420	31.19 (2.90)
ATSD4064	27.10 (2.52)	ATSD5420	18.32 (1.70)	ATSD7424	33.50 (3.11)
ATSD4068	28.30 (2.63)	ATSD5424	19.96 (1.85)	ATSD8007	25.40 (2.36)
ATSD4074	30.71 (2.85)	ATSD5428	21.61 (2.01)	ATSD8010	28.57 (2.65)
ATSD4080	33.11 (3.08)	ATSD5430	23.25 (2.16)	ATSD8020	36.17 (3.36)
ATSD4407	7.48 (0.70)	ATSD5434	24.90 (2.31)		
ATSD4410	9.12 (0.85)	ATSD5438	26.55 (2.47)		
ATSD4420	13.06 (1.21)	ATSD5440	28.19 (2.62)		
ATSD4424	14.37 (1.34)	ATSD5444	29.84 (2.77)		
ATSD4428	15.69 (1.46)	ATSD5448	31.48 (2.92)		

\* Dimensions in parentheses are in square meters.

**Sash-Set Springline™ Window Unobstructed Glass Dimensions and Area Specifications**

Window Number	Unobstructed Glass Width Inches/(mm)	Unobstructed Glass Height Inches/(mm)	Glass Area Sq. Ft./ (m <sup>2</sup> )
ATS1807	12 5/8" (321)	9 1/4" (235)	0.69 (0.06)
ATS1810	12 5/8" (321)	14 1/4" (362)	1.13 (0.10)
ATS1820	12 5/8" (321)	26 1/4" (667)	2.17 (0.20)
ATS1824	12 5/8" (321)	30 1/4" (768)	2.52 (0.23)
ATS1828	12 5/8" (321)	34 1/4" (870)	2.87 (0.27)
ATS1830	12 5/8" (321)	38 1/4" (972)	3.22 (0.30)
ATS1834	12 5/8" (321)	42 1/4" (1073)	3.57 (0.33)
ATS1838	12 5/8" (321)	46 1/4" (1175)	3.92 (0.36)
ATS1840	12 5/8" (321)	50 1/4" (1276)	4.27 (0.40)
ATS1844	12 5/8" (321)	54 1/4" (1378)	4.62 (0.43)
ATS1848	12 5/8" (321)	58 1/4" (1480)	4.97 (0.46)
ATS1850	12 5/8" (321)	62 1/4" (1581)	5.32 (0.49)
ATS1854	12 5/8" (321)	66 1/4" (1683)	5.67 (0.53)
ATS1858	12 5/8" (321)	70 1/4" (1784)	6.02 (0.56)
ATS1860	12 5/8" (321)	74 1/4" (1886)	6.37 (0.59)
ATS1864	12 5/8" (321)	78 1/4" (1988)	6.72 (0.62)
ATS1868	12 5/8" (321)	82 1/4" (2089)	7.07 (0.66)
ATS1874	12 5/8" (321)	90 1/4" (2292)	7.77 (0.72)
ATS1880	12 5/8" (321)	98 1/4" (2496)	8.47 (0.79)
ATS2007	16 5/8" (422)	11 1/4" (286)	1.09 (0.10)
ATS2010	16 5/8" (422)	16 1/4" (413)	1.66 (0.15)
ATS2020	16 5/8" (422)	28 1/4" (718)	3.05 (0.28)
ATS2024	16 5/8" (422)	32 1/4" (819)	3.51 (0.33)
ATS2028	16 5/8" (422)	36 1/4" (921)	3.97 (0.37)
ATS2030	16 5/8" (422)	40 1/4" (1022)	4.43 (0.41)
ATS2034	16 5/8" (422)	44 1/4" (1124)	4.89 (0.45)
ATS2038	16 5/8" (422)	48 1/4" (1226)	5.35 (0.50)
ATS2040	16 5/8" (422)	52 1/4" (1327)	5.81 (0.54)
ATS2044	16 5/8" (422)	56 1/4" (1429)	6.27 (0.58)
ATS2048	16 5/8" (422)	60 1/4" (1530)	6.73 (0.63)
ATS2050	16 5/8" (422)	64 1/4" (1632)	7.20 (0.67)
ATS2054	16 5/8" (422)	68 1/4" (1734)	7.66 (0.71)
ATS2058	16 5/8" (422)	72 1/4" (1835)	8.12 (0.75)
ATS2060	16 5/8" (422)	76 1/4" (1937)	8.58 (0.80)
ATS2064	16 5/8" (422)	80 1/4" (2038)	9.04 (0.84)
ATS2068	16 5/8" (422)	84 1/4" (2140)	9.50 (0.88)
ATS2074	16 5/8" (422)	92 1/4" (2343)	10.42 (0.97)
ATS2080	16 5/8" (422)	100 1/4" (2546)	11.34 (1.05)
ATS2407	20 5/8" (524)	13 1/4" (337)	1.57 (0.15)
ATS2410	20 5/8" (524)	18 1/4" (464)	2.29 (0.21)
ATS2420	20 5/8" (524)	30 1/4" (768)	4.01 (0.37)
ATS2424	20 5/8" (524)	34 1/4" (870)	4.58 (0.43)
ATS2428	20 5/8" (524)	38 1/4" (972)	5.15 (0.48)
ATS2430	20 5/8" (524)	42 1/4" (1073)	5.72 (0.53)
ATS2434	20 5/8" (524)	46 1/4" (1175)	6.29 (0.58)
ATS2438	20 5/8" (524)	50 1/4" (1276)	6.87 (0.64)
ATS2440	20 5/8" (524)	54 1/4" (1378)	7.44 (0.69)
ATS2444	20 5/8" (524)	58 1/4" (1480)	8.01 (0.74)
ATS2448	20 5/8" (524)	62 1/4" (1581)	8.58 (0.80)
ATS2450	20 5/8" (524)	66 1/4" (1683)	9.15 (0.85)
ATS2454	20 5/8" (524)	70 1/4" (1784)	9.73 (0.90)
ATS2458	20 5/8" (524)	74 1/4" (1886)	10.30 (0.96)
ATS2460	20 5/8" (524)	78 1/4" (1988)	10.87 (1.01)
ATS2464	20 5/8" (524)	82 1/4" (2089)	11.44 (1.06)
ATS2468	20 5/8" (524)	86 1/4" (2191)	12.01 (1.12)
ATS2474	20 5/8" (524)	94 1/4" (2394)	13.16 (1.22)
ATS2480	20 5/8" (524)	102 1/4" (2597)	14.30 (1.33)
ATS2607	22 5/8" (575)	14 1/4" (362)	1.85 (0.17)
ATS2610	22 5/8" (575)	19 1/4" (489)	2.64 (0.25)
ATS2620	22 5/8" (575)	31 1/4" (794)	4.52 (0.42)

Window Number	Unobstructed Glass Width Inches/(mm)	Unobstructed Glass Height Inches/(mm)	Glass Area Sq. Ft./ (m <sup>2</sup> )
ATS2624	22 5/8" (575)	35 1/4" (895)	5.15 (0.48)
ATS2628	22 5/8" (575)	39 1/4" (997)	5.77 (0.54)
ATS2630	22 5/8" (575)	43 1/4" (1099)	6.40 (0.59)
ATS2634	22 5/8" (575)	47 1/4" (1200)	7.03 (0.65)
ATS2638	22 5/8" (575)	51 1/4" (1302)	7.66 (0.71)
ATS2640	22 5/8" (575)	55 1/4" (1403)	8.28 (0.77)
ATS2644	22 5/8" (575)	59 1/4" (1505)	8.91 (0.83)
ATS2648	22 5/8" (575)	63 1/4" (1607)	9.54 (0.89)
ATS2650	22 5/8" (575)	67 1/4" (1708)	10.17 (0.94)
ATS2654	22 5/8" (575)	71 1/4" (1810)	10.79 (1.00)
ATS2658	22 5/8" (575)	75 1/4" (1911)	11.42 (1.06)
ATS2660	22 5/8" (575)	79 1/4" (2013)	12.05 (1.12)
ATS2664	22 5/8" (575)	83 1/4" (2115)	12.68 (1.18)
ATS2668	22 5/8" (575)	87 1/4" (2216)	13.30 (1.24)
ATS2674	22 5/8" (575)	95 1/4" (2419)	14.56 (1.35)
ATS2680	22 5/8" (575)	103 1/4" (2623)	15.81 (1.47)
ATS2807	24 5/8" (625)	15 1/4" (387)	2.15 (0.20)
ATS2810	24 5/8" (625)	20 1/4" (514)	3.00 (0.28)
ATS2820	24 5/8" (625)	32 1/4" (819)	5.05 (0.47)
ATS2824	24 5/8" (625)	36 1/4" (921)	5.74 (0.53)
ATS2828	24 5/8" (625)	40 1/4" (1022)	6.42 (0.60)
ATS2830	24 5/8" (625)	44 1/4" (1124)	7.10 (0.66)
ATS2834	24 5/8" (625)	48 1/4" (1226)	7.78 (0.72)
ATS2838	24 5/8" (625)	52 1/4" (1327)	8.47 (0.79)
ATS2840	24 5/8" (625)	56 1/4" (1429)	9.15 (0.85)
ATS2844	24 5/8" (625)	60 1/4" (1530)	9.83 (0.91)
ATS2848	24 5/8" (625)	64 1/4" (1632)	10.52 (0.98)
ATS2850	24 5/8" (625)	68 1/4" (1734)	11.20 (1.04)
ATS2854	24 5/8" (625)	72 1/4" (1835)	11.88 (1.10)
ATS2858	24 5/8" (625)	76 1/4" (1937)	12.57 (1.17)
ATS2860	24 5/8" (625)	80 1/4" (2038)	13.25 (1.23)
ATS2864	24 5/8" (625)	84 1/4" (2140)	13.93 (1.29)
ATS2868	24 5/8" (625)	88 1/4" (2242)	14.62 (1.36)
ATS2874	24 5/8" (625)	96 1/4" (2445)	15.98 (1.48)
ATS2880	24 5/8" (625)	104 1/4" (2648)	17.35 (1.61)
ATS21007	26 5/8" (676)	16 1/4" (413)	2.47 (0.23)
ATS21010	26 5/8" (676)	21 1/4" (540)	3.39 (0.31)
ATS21020	26 5/8" (676)	33 1/4" (845)	5.61 (0.52)
ATS21024	26 5/8" (676)	37 1/4" (946)	6.35 (0.59)
ATS21028	26 5/8" (676)	41 1/4" (1048)	7.09 (0.66)
ATS21030	26 5/8" (676)	45 1/4" (1149)	7.82 (0.73)
ATS21034	26 5/8" (676)	49 1/4" (1251)	8.56 (0.80)
ATS21038	26 5/8" (676)	53 1/4" (1353)	9.30 (0.86)
ATS21040	26 5/8" (676)	57 1/4" (1454)	10.04 (0.93)
ATS21044	26 5/8" (676)	61 1/4" (1556)	10.78 (1.00)
ATS21048	26 5/8" (676)	65 1/4" (1657)	11.52 (1.07)
ATS21050	26 5/8" (676)	69 1/4" (1759)	12.26 (1.14)
ATS21054	26 5/8" (676)	73 1/4" (1861)	13.00 (1.21)
ATS21058	26 5/8" (676)	77 1/4" (1962)	13.73 (1.28)
ATS21060	26 5/8" (676)	81 1/4" (2064)	14.47 (1.34)
ATS21064	26 5/8" (676)	85 1/4" (2165)	15.21 (1.41)
ATS21068	26 5/8" (676)	89 1/4" (2267)	15.95 (1.48)
ATS21074	26 5/8" (676)	97 1/4" (2470)	17.43 (1.62)
ATS21080	26 5/8" (676)	105 1/4" (2673)	18.90 (1.76)
ATS3007	28 5/8" (727)	17 1/4" (438)	2.81 (0.26)
ATS3010	28 5/8" (727)	22 1/4" (565)	3.80 (0.35)
ATS3020	28 5/8" (727)	34 1/4" (870)	6.19 (0.58)
ATS3024	28 5/8" (727)	38 1/4" (972)	6.98 (0.65)
ATS3028	28 5/8" (727)	42 1/4" (1073)	7.77 (0.72)
ATS3030	28 5/8" (727)	46 1/4" (1175)	8.57 (0.80)

Window Number	Unobstructed Glass Width Inches/(mm)	Unobstructed Glass Height Inches/(mm)	Glass Area Sq. Ft./ (m <sup>2</sup> )
ATS3034	28 5/8" (727)	50 1/4" (1276)	9.36 (0.87)
ATS3038	28 5/8" (727)	54 1/4" (1378)	10.16 (0.94)
ATS3040	28 5/8" (727)	58 1/4" (1480)	10.95 (1.02)
ATS3044	28 5/8" (727)	62 1/4" (1581)	11.75 (1.09)
ATS3048	28 5/8" (727)	66 1/4" (1683)	12.54 (1.17)
ATS3050	28 5/8" (727)	70 1/4" (1784)	13.33 (1.24)
ATS3054	28 5/8" (727)	74 1/4" (1886)	14.13 (1.31)
ATS3058	28 5/8" (727)	78 1/4" (1988)	14.92 (1.39)
ATS3060	28 5/8" (727)	82 1/4" (2089)	15.72 (1.46)
ATS3064	28 5/8" (727)	86 1/4" (2191)	16.51 (1.53)
ATS3068	28 5/8" (727)	90 1/4" (2292)	17.31 (1.61)
ATS3074	28 5/8" (727)	98 1/4" (2496)	18.89 (1.75)
ATS3080	28 5/8" (727)	106 1/4" (2699)	20.48 (1.90)
ATS3207	30 5/8" (778)	18 1/4" (464)	3.17 (0.29)
ATS3210	30 5/8" (778)	23 1/4" (591)	4.24 (0.39)
ATS3220	30 5/8" (778)	35 1/4" (895)	6.79 (0.63)
ATS3224	30 5/8" (778)	39 1/4" (997)	7.63 (0.71)
ATS3228	30 5/8" (778)	43 1/4" (1099)	8.48 (0.79)
ATS3230	30 5/8" (778)	47 1/4" (1200)	9.33 (0.87)
ATS3234	30 5/8" (778)	51 1/4" (1302)	10.18 (0.95)
ATS3238	30 5/8" (778)	55 1/4" (1403)	11.03 (1.02)
ATS3240	30 5/8" (778)	59 1/4" (1505)	11.88 (1.10)
ATS3244	30 5/8" (778)	63 1/4" (1607)	12.73 (1.18)
ATS3248	30 5/8" (778)	67 1/4" (1708)	13.58 (1.26)
ATS3250	30 5/8" (778)	71 1/4" (1810)	14.43 (1.34)
ATS3254	30 5/8" (778)	75 1/4" (1911)	15.28 (1.42)
ATS3258	30 5/8" (778)	79 1/4" (2013)	16.13 (1.50)
ATS3260	30 5/8" (778)	83 1/4" (2115)	16.98 (1.58)
ATS3264	30 5/8" (778)	87 1/4" (2216)	17.83 (1.66)
ATS3268	30 5/8" (778)	91 1/4" (2318)	18.68 (1.74)
ATS3274	30 5/8" (778)	99 1/4" (2521)	20.38 (1.89)
ATS3280	30 5/8" (778)	107 1/4" (2724)	22.08 (2.05)
ATS3407	32 5/8" (829)	19 1/4" (489)	3.56 (0.33)
ATS3410	32 5/8" (829)	24 1/4" (616)	4.69 (0.44)
ATS3420	32 5/8" (829)	36 1/4" (921)	7.41 (0.69)
ATS3424	32 5/8" (829)	40 1/4" (1022)	8.31 (0.77)
ATS3428	32 5/8" (829)	44 1/4" (1124)	9.22 (0.86)
ATS3430	32 5/8" (829)	48 1/4" (1226)	10.12 (0.94)
ATS3434	32 5/8" (829)	52 1/4" (1327)	11.03 (1.02)
ATS3438	32 5/8" (829)	56 1/4" (1429)	11.93 (1.11)
ATS3440	32 5/8" (829)	60 1/4" (1530)	12.84 (1.19)
ATS3444	32 5/8" (829)	64 1/4" (1632)	13.74 (1.28)
ATS3448	32 5/8" (829)	68 1/4" (1734)	14.65 (1.36)
ATS3450	32 5/8" (829)	72 1/4" (1835)	15.55 (1.44)
ATS3454	32 5/8" (829)	76 1/4" (1937)	16.46 (1.53)
ATS3458	32 5/8" (829)	80 1/4" (2038)	17.37 (1.61)
ATS3460	32 5/8" (829)	84 1/4" (2140)	18.27 (1.70)
ATS3464	32 5/8" (829)	88 1/4" (2242)	19.18 (1.78)
ATS3468	32 5/8" (829)	92 1/4" (2343)	20.08 (1.87)
ATS3474	32 5/8" (829)	100 1/4" (2546)	21.89 (2.03)
ATS3480	32 5/8" (829)	108 1/4" (2750)	23.70 (2.20)
ATS3807	36 5/8" (930)	21 1/4" (540)	4.39 (0.41)
ATS3810	36 5/8" (930)	26 1/4" (667)	5.67 (0.53)
ATS3820	36 5/8" (930)	38 1/4" (972)	8.71 (0.81)
ATS3824	36 5/8" (930)	42 1/4" (1073)	9.73 (0.90)
ATS3828	36 5/8" (930)	46 1/4" (1175)	10.75 (1.00)
ATS3830	36 5/8" (930)	50 1/4" (1276)	11.76 (1.09)
ATS3834	36 5/8" (930)	54 1/4" (1378)	12.78 (1.19)
ATS3838	36 5/8" (930)	58 1/4" (1480)	13.80 (1.28)

\*Dimensions in parentheses are in millimeters or square meters.

continued on next page

## Sash-Set Springline™ Window Unobstructed Glass Dimensions and Area Specifications (continued)

Window Number	Unobstructed Glass Width Inches/(mm)	Unobstructed Glass Height Inches/(mm)	Glass Area Sq. Ft./ (m <sup>2</sup> )	Window Number	Unobstructed Glass Width Inches/(mm)	Unobstructed Glass Height Inches/(mm)	Glass Area Sq. Ft./ (m <sup>2</sup> )	Window Number	Unobstructed Glass Width Inches/(mm)	Unobstructed Glass Height Inches/(mm)	Glass Area Sq. Ft./ (m <sup>2</sup> )
ATS3840	36 5/8" (930)	62 1/4" (1581)	14.81 (1.38)	ATS4858	48 5/8" (1235)	84 1/4" (2140)	26.66 (2.48)	ATS6030	64 5/8" (1641)	60 1/4" (1530)	23.90 (2.22)
ATS3844	36 5/8" (930)	66 1/4" (1683)	15.83 (1.47)	ATS4860	48 5/8" (1235)	88 1/4" (2242)	28.01 (2.60)	ATS6034	64 5/8" (1641)	64 1/4" (1632)	25.70 (2.39)
ATS3848	36 5/8" (930)	70 1/4" (1784)	16.85 (1.57)	ATS4864	48 5/8" (1235)	92 1/4" (2343)	29.36 (2.73)	ATS6038	64 5/8" (1641)	68 1/4" (1734)	27.49 (2.55)
ATS3850	36 5/8" (930)	74 1/4" (1886)	17.86 (1.66)	ATS4868	48 5/8" (1235)	96 1/4" (2445)	30.71 (2.85)	ATS6040	64 5/8" (1641)	72 1/4" (1835)	29.29 (2.72)
ATS3854	36 5/8" (930)	78 1/4" (1988)	18.88 (1.75)	ATS4874	48 5/8" (1235)	100 1/4" (2546)	32.06 (2.98)	ATS6044	64 5/8" (1641)	76 1/4" (1937)	31.08 (2.89)
ATS3858	36 5/8" (930)	82 1/4" (2089)	19.90 (1.85)	ATS5007	48 5/8" (1235)	108 1/4" (2750)	34.76 (3.23)	ATS6048	64 5/8" (1641)	80 1/4" (2038)	32.87 (3.05)
ATS3860	36 5/8" (930)	86 1/4" (2191)	20.91 (1.94)	ATS5010	52 5/8" (1337)	29 1/4" (743)	8.61 (0.80)	ATS6050	64 5/8" (1641)	84 1/4" (2140)	34.67 (3.22)
ATS3864	36 5/8" (930)	90 1/4" (2292)	21.93 (2.04)	ATS5020	52 5/8" (1337)	34 1/4" (870)	10.44 (0.97)	ATS6054	64 5/8" (1641)	88 1/4" (2242)	36.46 (3.39)
ATS3868	36 5/8" (930)	94 1/4" (2394)	22.95 (2.13)	ATS5024	52 5/8" (1337)	46 1/4" (1175)	14.82 (1.38)	ATS6407	64 5/8" (1641)	92 1/4" (2343)	38.26 (3.55)
ATS3874	36 5/8" (930)	102 1/4" (2597)	24.98 (2.32)	ATS5028	52 5/8" (1337)	50 1/4" (1276)	16.28 (1.51)	ATS6410	68 5/8" (1743)	37 1/4" (946)	14.22 (1.32)
ATS3880	36 5/8" (930)	110 1/4" (2800)	27.01 (2.51)	ATS5030	52 5/8" (1337)	54 1/4" (1378)	17.74 (1.65)	ATS6420	68 5/8" (1743)	42 1/4" (1073)	16.60 (1.54)
ATS4007	40 5/8" (1032)	23 1/4" (591)	5.32 (0.49)	ATS5034	52 5/8" (1337)	58 1/4" (1480)	19.20 (1.78)	ATS6424	68 5/8" (1743)	54 1/4" (1378)	22.32 (2.07)
ATS4010	40 5/8" (1032)	28 1/4" (718)	6.73 (0.63)	ATS5038	52 5/8" (1337)	62 1/4" (1581)	20.66 (1.92)	ATS6428	68 5/8" (1743)	58 1/4" (1480)	24.23 (2.25)
ATS4020	40 5/8" (1032)	40 1/4" (1022)	10.11 (0.94)	ATS5040	52 5/8" (1337)	66 1/4" (1683)	22.12 (2.06)	ATS6807	68 5/8" (1743)	62 1/4" (1581)	26.13 (2.43)
ATS4024	40 5/8" (1032)	44 1/4" (1124)	11.24 (1.04)	ATS5044	52 5/8" (1337)	70 1/4" (1784)	23.59 (2.19)	ATS6810	72 5/8" (1845)	39 1/4" (997)	15.84 (1.47)
ATS4028	40 5/8" (1032)	48 1/4" (1226)	12.37 (1.15)	ATS5048	52 5/8" (1337)	74 1/4" (1886)	25.05 (2.33)	ATS6820	72 5/8" (1845)	44 1/4" (1124)	18.37 (1.71)
ATS4030	40 5/8" (1032)	52 1/4" (1327)	13.49 (1.25)	ATS5050	52 5/8" (1337)	78 1/4" (1988)	26.51 (2.46)	ATS6824	72 5/8" (1845)	56 1/4" (1429)	24.41 (2.27)
ATS4034	40 5/8" (1032)	56 1/4" (1429)	14.62 (1.36)	ATS5054	52 5/8" (1337)	82 1/4" (2089)	27.97 (2.60)	ATS6828	72 5/8" (1845)	60 1/4" (1530)	26.43 (2.46)
ATS4038	40 5/8" (1032)	60 1/4" (1530)	15.75 (1.46)	ATS5058	52 5/8" (1337)	86 1/4" (2191)	29.43 (2.73)	ATS7007	72 5/8" (1845)	64 1/4" (1632)	28.45 (2.64)
ATS4040	40 5/8" (1032)	64 1/4" (1632)	16.88 (1.57)	ATS5060	52 5/8" (1337)	90 1/4" (2292)	30.89 (2.87)	ATS7010	76 5/8" (1946)	41 1/4" (1048)	17.55 (1.63)
ATS4044	40 5/8" (1032)	68 1/4" (1734)	18.00 (1.67)	ATS5064	52 5/8" (1337)	94 1/4" (2394)	32.35 (3.01)	ATS7020	76 5/8" (1946)	46 1/4" (1175)	20.21 (1.88)
ATS4048	40 5/8" (1032)	72 1/4" (1835)	19.13 (1.78)	ATS5068	52 5/8" (1337)	98 1/4" (2496)	33.81 (3.14)	ATS7024	76 5/8" (1946)	58 1/4" (1480)	26.60 (2.47)
ATS4050	40 5/8" (1032)	76 1/4" (1937)	20.26 (1.88)	ATS5074	52 5/8" (1337)	102 1/4" (2597)	35.27 (3.28)	ATS7407	76 5/8" (1946)	62 1/4" (1581)	28.72 (2.67)
ATS4054	40 5/8" (1032)	80 1/4" (2038)	21.39 (1.99)	ATS5407	52 5/8" (1337)	110 1/4" (2800)	38.19 (3.55)	ATS7410	80 5/8" (2048)	43 1/4" (1099)	19.35 (1.80)
ATS4058	40 5/8" (1032)	84 1/4" (2140)	22.51 (2.09)	ATS5410	56 5/8" (1438)	31 1/4" (794)	9.88 (0.92)	ATS7420	80 5/8" (2048)	48 1/4" (1226)	22.15 (2.06)
ATS4060	40 5/8" (1032)	88 1/4" (2242)	23.64 (2.20)	ATS5420	56 5/8" (1438)	36 1/4" (921)	11.85 (1.10)	ATS7424	80 5/8" (2048)	60 1/4" (1530)	28.86 (2.68)
ATS4064	40 5/8" (1032)	92 1/4" (2343)	24.77 (2.30)	ATS5424	56 5/8" (1438)	48 1/4" (1226)	16.56 (1.54)	ATS8007	80 5/8" (2048)	64 1/4" (1632)	31.10 (2.89)
ATS4068	40 5/8" (1032)	96 1/4" (2445)	25.90 (2.41)	ATS5428	56 5/8" (1438)	52 1/4" (1327)	18.14 (1.69)	ATS8010	80 5/8" (2048)	47 1/4" (1200)	23.20 (2.16)
ATS4074	40 5/8" (1032)	104 1/4" (2648)	28.15 (2.62)	ATS5430	56 5/8" (1438)	56 1/4" (1429)	19.71 (1.83)	ATS8020	80 5/8" (2048)	52 1/4" (1327)	26.28 (2.44)
ATS4080	40 5/8" (1032)	112 1/4" (2851)	30.41 (2.83)	ATS5434	56 5/8" (1438)	60 1/4" (1530)	21.28 (1.98)	ATS4854	80 5/8" (2048)	64 1/4" (1632)	33.66 (3.13)
ATS4407	44 5/8" (1133)	25 1/4" (641)	6.33 (0.59)	ATS5438	56 5/8" (1438)	64 1/4" (1632)	22.85 (2.12)				
ATS4410	44 5/8" (1133)	30 1/4" (768)	7.88 (0.73)	ATS5440	56 5/8" (1438)	68 1/4" (1734)	24.42 (2.27)				
ATS4420	44 5/8" (1133)	42 1/4" (1073)	11.59 (1.08)	ATS5444	56 5/8" (1438)	72 1/4" (1835)	26.00 (2.42)				
ATS4424	44 5/8" (1133)	46 1/4" (1175)	12.83 (1.19)	ATS5448	56 5/8" (1438)	76 1/4" (1937)	27.57 (2.56)				
ATS4428	44 5/8" (1133)	50 1/4" (1276)	14.07 (1.31)	ATS5450	56 5/8" (1438)	80 1/4" (2038)	29.14 (2.71)				
ATS4430	44 5/8" (1133)	54 1/4" (1378)	15.31 (1.42)	ATS5454	56 5/8" (1438)	84 1/4" (2140)	30.71 (2.85)				
ATS4434	44 5/8" (1133)	58 1/4" (1480)	16.55 (1.54)	ATS5458	56 5/8" (1438)	88 1/4" (2242)	32.28 (3.00)				
ATS4438	44 5/8" (1133)	62 1/4" (1581)	17.79 (1.65)	ATS5460	56 5/8" (1438)	92 1/4" (2343)	33.86 (3.15)				
ATS4440	44 5/8" (1133)	66 1/4" (1683)	19.02 (1.77)	ATS5464	56 5/8" (1438)	96 1/4" (2445)	35.43 (3.29)				
ATS4444	44 5/8" (1133)	70 1/4" (1784)	20.26 (1.88)	ATS5468	56 5/8" (1438)	100 1/4" (2546)	37.00 (3.44)				
ATS4448	44 5/8" (1133)	74 1/4" (1886)	21.50 (2.00)	ATS5807	56 5/8" (1438)	104 1/4" (2648)	38.57 (3.58)				
ATS4450	44 5/8" (1133)	78 1/4" (1988)	22.74 (2.11)	ATS5810	60 5/8" (1540)	33 1/4" (845)	11.24 (1.04)				
ATS4454	44 5/8" (1133)	82 1/4" (2089)	23.98 (2.23)	ATS5820	60 5/8" (1540)	38 1/4" (972)	13.35 (1.24)				
ATS4458	44 5/8" (1133)	86 1/4" (2191)	25.22 (2.34)	ATS5824	60 5/8" (1540)	50 1/4" (1276)	18.40 (1.71)				
ATS4460	44 5/8" (1133)	90 1/4" (2292)	26.46 (2.46)	ATS5828	60 5/8" (1540)	54 1/4" (1378)	20.08 (1.87)				
ATS4464	44 5/8" (1133)	94 1/4" (2394)	27.70 (2.57)	ATS5830	60 5/8" (1540)	58 1/4" (1480)	21.76 (2.02)				
ATS4468	44 5/8" (1133)	98 1/4" (2496)	28.93 (2.69)	ATS5834	60 5/8" (1540)	62 1/4" (1581)	23.45 (2.18)				
ATS4474	44 5/8" (1133)	106 1/4" (2699)	31.41 (2.92)	ATS5838	60 5/8" (1540)	66 1/4" (1683)	25.13 (2.33)				
ATS4807	48 5/8" (1235)	27 1/4" (692)	7.43 (0.69)	ATS5840	60 5/8" (1540)	70 1/4" (1784)	26.81 (2.49)				
ATS4810	48 5/8" (1235)	32 1/4" (819)	9.11 (0.85)	ATS5844	60 5/8" (1540)	74 1/4" (1886)	28.49 (2.65)				
ATS4820	48 5/8" (1235)	44 1/4" (1124)	13.16 (1.22)	ATS5848	60 5/8" (1540)	78 1/4" (1988)	30.18 (2.80)				
ATS4824	48 5/8" (1235)	48 1/4" (1226)	14.51 (1.35)	ATS5850	60 5/8" (1540)	82 1/4" (2089)	31.86 (2.96)				
ATS4828	48 5/8" (1235)	52 1/4" (1327)	15.86 (1.47)	ATS5854	60 5/8" (1540)	86 1/4" (2191)	33.54 (3.12)				
ATS4830	48 5/8" (1235)	56 1/4" (1429)	17.21 (1.60)	ATS5858	60 5/8" (1540)	90 1/4" (2292)	35.23 (3.27)				
ATS4834	48 5/8" (1235)	60 1/4" (1530)	18.56 (1.72)	ATS5860	60 5/8" (1540)	94 1/4" (2394)	36.91 (3.43)				
ATS4838	48 5/8" (1235)	64 1/4" (1632)	19.91 (1.85)	ATS6007	60 5/8" (1540)	98 1/4" (2496)	38.59 (3.59)				
ATS4840	48 5/8" (1235)	68 1/4" (1734)	21.26 (1.98)	ATS6010	64 5/8" (1641)	35 1/4" (895)	12.69 (1.18)				
ATS4844	48 5/8" (1235)	72 1/4" (1835)	22.61 (2.10)	ATS6020	64 5/8" (1641)	40 1/4" (1022)	14.93 (1.39)				
ATS4848	48 5/8" (1235)	76 1/4" (1937)	23.96 (2.23)	ATS6024	64 5/8" (1641)	52 1/4" (1327)	20.31 (1.89)				
ATS4850	48 5/8" (1235)	80 1/4" (2038)	25.31 (2.35)	ATS6028	64 5/8" (1641)	56 1/4" (1429)	22.11 (2.05)				

\* Dimensions in parentheses are in millimeters or square meters.

**Direct-Set Specialty Window Details**

Scale 1 1/2" (38) = 1'-0" (305) – 1:8

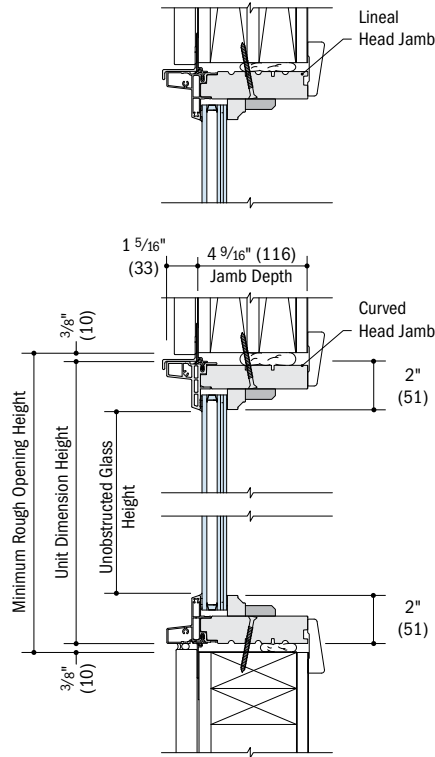

Vertical Section

**Sash-Set Specialty Window Details**

Scale 1 1/2" (38) = 1'-0" (305) – 1:8

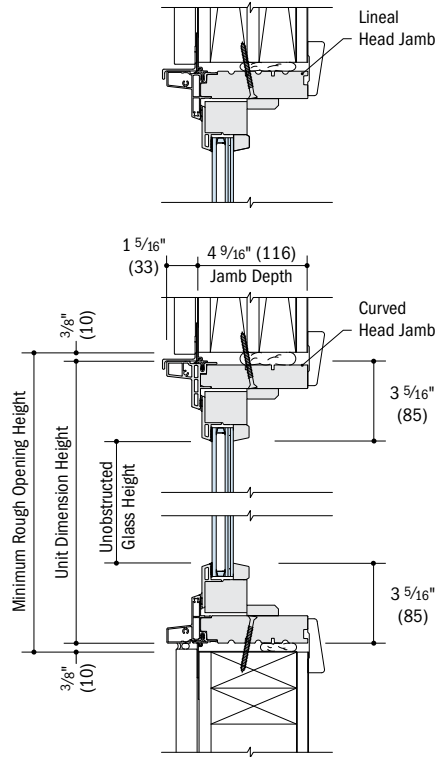

Vertical Section

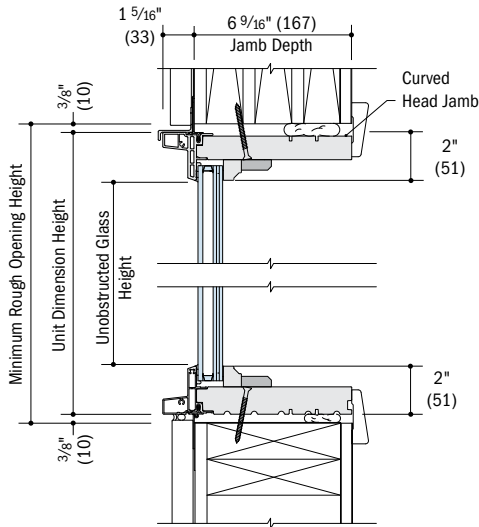

Vertical Section

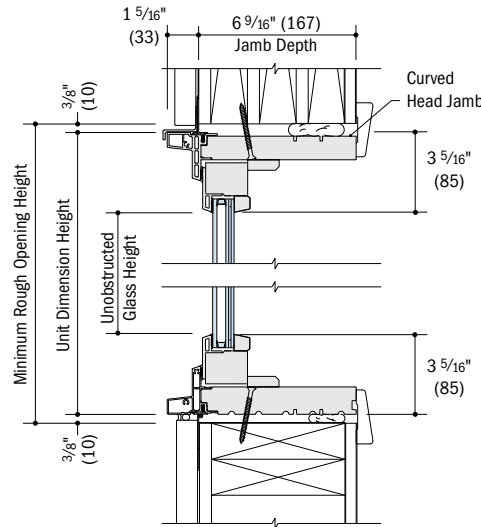

Vertical Section

Both lineal and curved head jambs are shown. Choose detail based on your specialty window shape.

Sash-set specialty and direct-set specialty windows are available in both 4 9/16" (116) and 6 9/16" (167) base jamb depths.

Oval windows are only available direct-set.

See page 102 for horizontal joining details.

- 4 9/16" (116) and 6 9/16" (167) jamb depth measurement is from back side of installation flange.
- Light-colored areas are parts included with window. Dark-colored areas are additional Andersen® parts required to complete window assembly as shown.
- Dimensions in parentheses are in millimeters.
- **Minimum rough opening dimensions may need to be increased to allow for use of building wraps, flashing, sill panning, brackets, fasteners or other items. See installation information on page 170.**
- Details are for illustration only and are not intended to represent product installation methods or materials. Refer to product installation guides at andersenwindows.com.

## Horizontal (stack) Joining Details

Scale 1 1/2" (38) = 1'-0" (305) – 1:8

Specialty windows can be joined to other windows using 3/4" (19) x 5 3/4" (146) fiberglass joining material for 4 9/16" (116) minimum wall depth.

3/4" (19) x 7 3/4" (197) fiberglass joining material is used for higher performance and it is required for Frenchwood® hinged inswing patio doors with 6 9/16" (167) base jamb depth. For factory-joined specialty-to-specialty window combinations, LVL joining material will be used. Fiberglass joining material is shown, except as noted. For additional window combinations, see pages 57-59.

### Overall "Window over Window" or

#### "Window over Door" Dimension Height

Sum of individual "window over window" or "window over door" heights plus 3/4" (19).

### Overall Minimum Rough Opening Height

Overall dimension height plus 3/4" (19).

For more joining information, see the combination designs section starting on page 148.

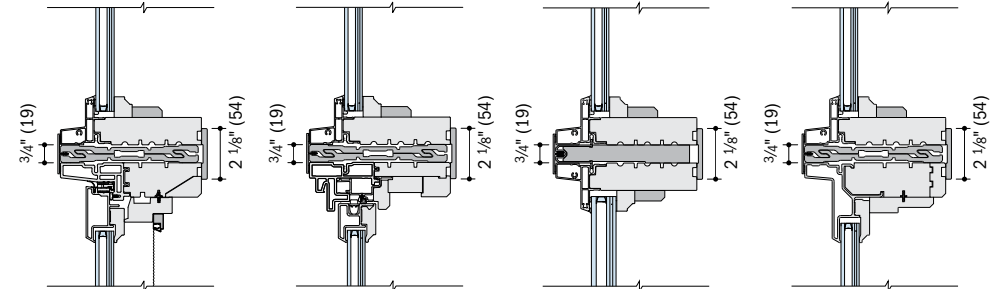

**Direct-Set Specialty over Casement/Awning**      **Direct-Set Specialty over Double-Hung**      **Direct-Set Specialty over Direct-Set Specialty**  
LVL (factory joined)      **Direct-Set Specialty over Picture**

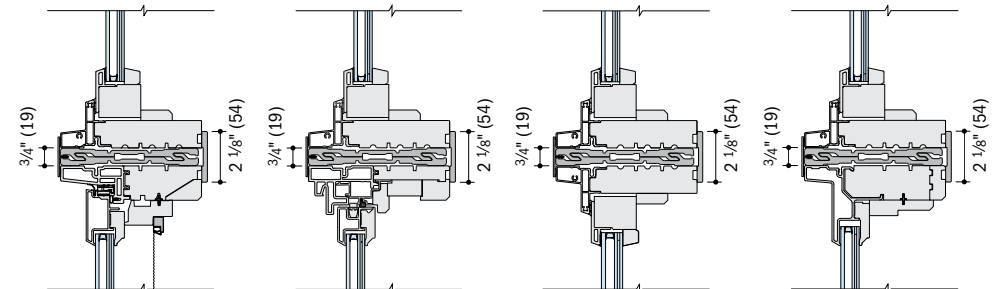

**Sash-Set Specialty over Casement/Awning**      **Sash-Set Specialty over Double-Hung**      **Sash-Set Specialty over Sash-Set Specialty**      **Sash-Set Specialty over Picture**

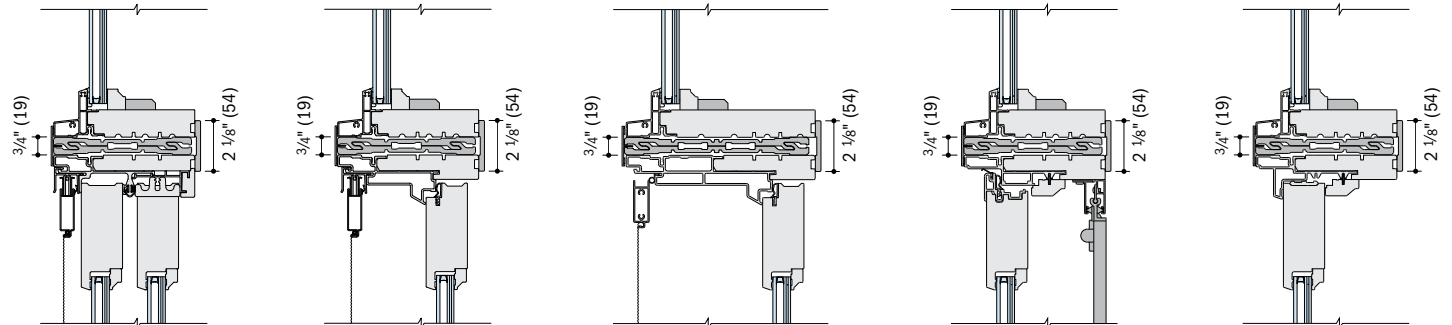

**Direct-Set Specialty over Frenchwood® Gliding Patio Door**      **Direct-Set Specialty over Frenchwood® Hinged Inswing Patio Door**  
4 9/16" (116) Jamb Depth      **Direct-Set Specialty over Frenchwood® Hinged Inswing Patio Door**  
6 9/16" (167) Jamb Depth      **Direct-Set Specialty over Frenchwood® Hinged Outswing Patio Door**      **Direct-Set Specialty over Frenchwood® Patio Door Sidelight**

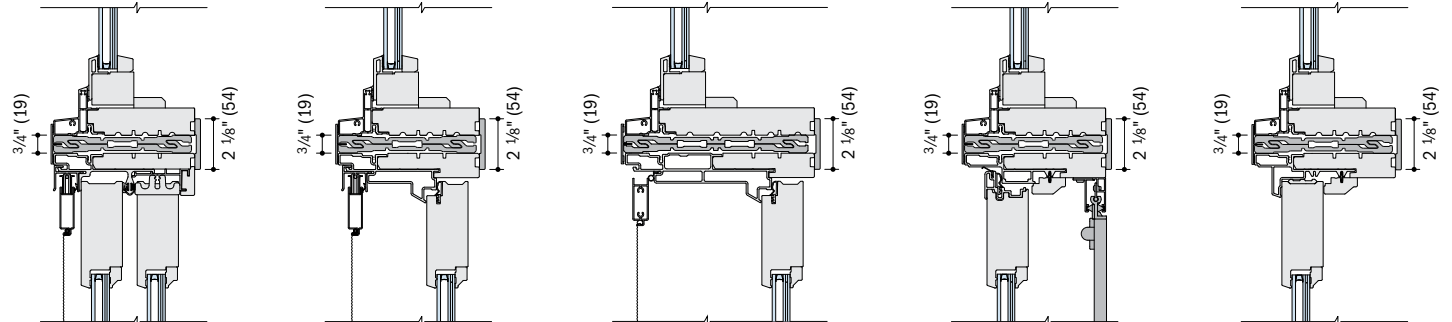

**Sash-Set Specialty over Frenchwood® Gliding Patio Door**      **Sash-Set Specialty over Frenchwood® Hinged Inswing Patio Door**  
4 9/16" (116) Jamb Depth      **Sash-Set Specialty over Frenchwood® Hinged Inswing Patio Door**  
6 9/16" (167) Jamb Depth      **Sash-Set Specialty over Frenchwood® Hinged Outswing Patio Door**      **Sash-Set Specialty over Frenchwood® Patio Door Sidelight**

- Light-colored areas are parts included with window. Dark-colored areas are additional Andersen® parts required to complete window assembly as shown.
- Dimensions in parentheses are in millimeters.
- **Minimum rough opening dimensions may need to be increased to allow for use of building wraps, flashing, sill panning, brackets, fasteners or other items. See installation information on page 170.**
- Details are for illustration only and are not intended to represent product installation methods or materials. Refer to product installation guides at andersenwindows.com.
- Structural performance of any combination is only as high as the lowest structural performance of any individual window or join in the combination.
- Andersen® products must be installed and anchored properly according to joining and installation guides to meet rated structural performance. Refer to product joining and installation guides at andersenwindows.com.



## FRENCHWOOD® PATIO DOORS

### Frenchwood Gliding

Table of Sizes .....	110-111
Specifications .....	111
Grille Patterns .....	123
Door Details .....	112-113

### Frenchwood Hinged Inswing

Table of Sizes .....	114-115
Specifications .....	116-117
Grille Patterns .....	123
Door Details .....	117-120

### Frenchwood Hinged Outswing

Table of Sizes .....	121
Specifications .....	122-123
Grille Patterns .....	123
Door Details .....	124-125

### Frenchwood Sidelights & Transoms

Table of Sizes .....	126-130
Specifications .....	130-131
Grille Patterns .....	131
Sidelight & Transom Details .....	132-133

Joining Details .....	134-137
-----------------------	---------

Custom Sizing .....	138-140
---------------------	---------

Combination Designs .....	148
---------------------------	-----

Product Performance .....	160
---------------------------	-----

**CUSTOM SIZING**  
in 1/8" (3) increments 

Dimensions in parentheses are in millimeters.



## FEATURES

### FRENCHWOOD GLIDING PATIO DOORS

#### FRAME

**A** Frame constructed with a wood core and a fiberglass exterior. This construction produces a rigid frame and a low-maintenance, durable exterior.

**B** Wood members are treated with a water-repellent preservative for long-lasting protection and performance.

The interior wood jamb has an extension jamb kerf, making it easy to add interior extension jambs to match wall depth.

**C** The weather seal is made from a flexible polyethylene leaf with a urethane foam core on the sill and stationary side jambs, and a polypropylene fin weatherstrip on the head and operating side jambs, creating a positive seal between the frame and panels. This system provides a long-lasting, energy-efficient barrier against wind, water and dust.

#### SILL

**D** One-piece fiberglass design provides superior water management. The nonconductive fiberglass construction enhances energy performance, and its superior strength eliminates the need for a sill support.

Slip- and wear-resistant poly bead finish available in either neutral gray or dark bronze color.

The roller track has a stainless steel cap that resists denting for smooth, reliable operation.

 **E** A factory-applied drop-nose channel attachment is available for enhanced water performance. See "Common Features" for details.

#### **F** GLASS

See "Common Features" for details.



#### PANEL

**G** Panel stiles and rails are constructed of an engineered LVL core. This LVL core provides strength and helps prevent warping for consistent smooth operation.

**H** Interior panel surfaces are constructed from premium wood veneer available in pine, maple, oak, cherry, mahogany\*\* and vertical grain Douglas fir. All prefinished interior options use water-based paints and stains.

**I** The exterior of the wood panel is protected with a Flexacron® paint system; this stabilized polyester paint is electrostatically applied to penetrate all exterior surfaces for maximum protection and a lustrous, low-maintenance finish.

Dual corrosion-resistant\* ball-bearing rollers on door panels provide smooth gliding operation with self-contained leveling adjusters.

Dual ball-bearing rollers have deep grooves to increase engagement with the roller track and resist lateral movement.

 A panel stiffener along the full length of the meeting stile supports the stationary panel when it is under structural pressure.

 Operating panels have a full-length stiffener on the edge of the meeting stile. The panel stiffener matches the interior wood species of the patio door for enhanced appearance.

A parting stop bracket adds strength to the door by reinforcing the top of the panels.

#### FLEXIBLE SEAL



A full-length combination weatherstrip/interlock system provides a flexible seal at the meeting stile. Shown above on a 400 Series Frenchwood gliding patio door.

#### MULTIPLE PANEL CONFIGURATIONS

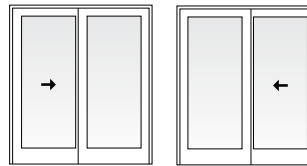

Two-Panel

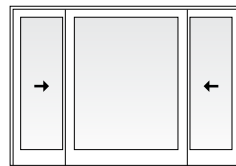

Three-Panel

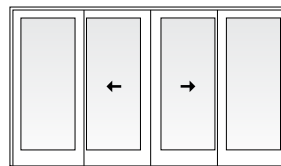

Four-Panel

#### HARDWARE

##### Multi-Point Locking System



The multi-point locking system features a unique reachout design that pulls the door panel tightly closed for a weathertight seal and enhanced security.



Lighthouse indicates differences from standard unit or optional upgrades.

\*Visit [andersenwindows.com/warranty](http://andersenwindows.com/warranty) for details.

\*\*Actual wood species is either Sapele or Sipo, both non-endangered species grown in Africa, with color and characteristics similar to Central American mahoganies.

"Flexacron" is a registered trademark of PPG Industries, Inc.

Andersen patio doors are not intended for use as entrance doors.

**FEATURES**

**FRENCHWOOD® HINGED INSWING PATIO DOORS**

**FRAME**

**A** Frame constructed with a wood core and a fiberglass exterior. This construction produces a rigid frame and a low-maintenance, durable exterior.

**B** Wood members are treated with a water-repellent preservative for long-lasting protection and performance.

The interior wood jamb has an extension jamb kerf, making it easy to add interior extension jambs to match wall depth.

Frenchwood hinged inswing patio doors are available in 4 9/16" (116) and 6 9/16" (167) base jamb depths.

**SILL**

**C** One-piece fiberglass design provides superior water management. The nonconductive fiberglass construction enhances energy performance, and its superior strength eliminates the need for a sill support.

Slip- and wear-resistant poly bead finish available in either neutral gray or dark bronze color.

**D** A factory-applied drop-nose channel attachment is available for enhanced water performance. See "Common Features" for details.



**E GLASS**

See "Common Features" for details.

**PANEL**

**F** Panel stiles and rails are constructed of an engineered LVL core. This LVL core provides strength and helps prevent warping for consistent smooth operation.

**G** Interior panel surfaces are constructed from premium wood veneer available in pine, maple, oak, cherry, mahogany\*\* and vertical grain Douglas fir. All prefinished interior options use water-based paints and stains.

**H** The exterior of the wood panel is protected with a Flexacron® paint system; this stabilized polyester paint is electrostatically applied to penetrate all exterior surfaces for maximum protection and a lustrous, low-maintenance finish.

**I** Factory-applied, one-piece (welded corners), compression-type weatherstrip made from a durable thermoplastic material is attached directly to the panel, not the frame, creating a continuous seal around the panel to provide maximum effectiveness against air and water infiltration. This system provides a long-lasting, energy-efficient barrier against wind, water and dust.

Two-panel doors are available with one or two active panels. For doors with one active panel, hinges can be located along either the jamb or astragal.

**Adjustable Hinges**

Adjustable hinges have ball-bearing pivots for smooth, frictionless movement and feature easy horizontal and vertical adjustments, plus a quick-release feature for

easy panel removal. Gold dust finish is standard on wood interior doors. For units with a prefinished white interior, white finish hinges are standard. Available in finishes that coordinate with most trim set hardware finishes.



**Removable Panels**

Panels can be easily removed with the unique panel-release tab on the hinge. Release tabs are covered with a cap for a clean appearance. This release feature is ideal for transporting large units up stairs or to other hard-to-reach areas.

**HARDWARE**

**Multi-Point Locking System**



Frenchwood hinged patio doors have a multi-point locking system that combines hook bolts with a center deadbolt. This system provides added weather-tightness and enhanced security.

**Optional Corrosion-Resistant Hardware**

Optional corrosion-resistant locking mechanism is available and recommended for applications within two miles of the coast and other harsh environments.

**COMMON FEATURES**

**GLASS**

**I** Impact-resistant glass construction provides industry-leading energy performance, sound control and added security.

Panels are silicone bed glazed and finished with an interior wood glass stop.

**J** Interior wood glass stops are secured using 1 1/2" (38) 16-gauge crown staples instead of nails. Silicone is also applied to the full perimeter of the glass on the interior side of the pane to add strength and stability.

A removable translucent film helps shield the glass from damage during delivery and construction and also simplifies finishing at the jobsite.

Obscure glass options are available, contact your Andersen supplier.

Consult local building codes for the glass most suitable to your area. High-performance options include:

- Low-E4® Impact-Resistant tempered glass
- Low-E4 HeatLock® Impact-Resistant tempered glass
- Low-E4 Sun Impact-Resistant tempered glass
- Low-E4 SmartSun™ Impact-Resistant tempered glass
- Low-E4 SmartSun HeatLock Impact-Resistant tempered glass

Standard Low-E4, Low-E4 HeatLock, Low-E4 Sun and Low-E4 SmartSun glass options are available for doors with PG upgrades.

Monolithic laminated options include:

- Clear Monolithic SmartSun Impact-Resistant tempered glass
- Gray Monolithic SmartSun Impact-Resistant tempered glass

**SILL**

**Performance Grade (PG) Upgrade Optional Drop-Nose Channel**



**K** A factory-applied, patented drop-nose channel is available when higher product performance is required. Drop-nose channel provides enhanced water performance without increasing interior sill height. Shown on a Frenchwood hinged inswing patio door. Details shown on page 113 for gliding patio doors and page 120 for hinged inswing patio doors.

**Drop-Nose Sill Cover**



Drop-nose sill cover is designed to cover the sill gap between two joined units. Available in all sill colors.

**TALLER HEIGHTS**

A-Series Frenchwood patio doors and patio door sidelights are available in heights up to 9'-11 1/2" (3023).

\*Visit andersenwindows.com/warranty for details.

\*\*Actual wood species is either Sapele or Sipo, both non-endangered species grown in Africa, with color and characteristics similar to Central American mahoganies.

†Flexacron® is a registered trademark of PPG Industries, Inc.

Dimensions in parentheses are in millimeters.

## FEATURES

### FRENCHWOOD HINGED OUTSWING PATIO DOORS

#### FRAME

**A** Frame constructed with a wood core and a fiberglass exterior. This construction produces a rigid frame and a low-maintenance, durable exterior.

**B** Wood members are treated with a water-repellent preservative for long-lasting protection and performance.

The interior wood jamb has an extension jamb kerf, making it easy to add interior extension jambs to match wall depth.

#### SILL

**C** One-piece, non-conductive fiberglass construction enhances energy performance, and its superior strength eliminates the need for a sill support. An innovative sill design provides superior water management.

Slip- and wear-resistant poly bead finish available in either neutral gray or dark bronze color.

**D** A factory-applied drop-nose channel attachment is available for enhanced water performance. See "Common Features" for details.

#### GLASS

See "Common Features" for details.



#### PANEL

**F** Panel stiles and rails are constructed of an engineered LVL core. This LVL core provides strength and helps prevent warping for consistent smooth operation.

**G** Interior panel surfaces are constructed from premium wood veneer available in pine, maple, oak, cherry, mahogany\*\* and vertical grain Douglas fir. All prefinished interior options use water-based paints and stains.

**H** The exterior of the wood panel is protected with a Flexacron® paint system; this stabilized polyester paint is electrostatically applied to penetrate all exterior surfaces for maximum protection and a lustrous, low-maintenance finish.

**I** Factory-applied, one-piece (welded corners), compression-type weatherstrip made from a durable thermoplastic material is attached directly to the panel, not the frame, creating a continuous seal around the panel to provide maximum effectiveness against air and water infiltration. This system provides a long-lasting, energy-efficient barrier against wind, water and dust.

Hinged outswing operating panels are available in either single left- or right-hand active or two-panel active-passive or passive-active jamb-hinged.

#### Adjustable Hinges

**J** The ball-bearing hinges are covered with a corrosion-resistant powder-coat finish. Adjustable hinges have ball-bearing pivots for smooth, frictionless movement and feature easy horizontal and vertical adjustments, plus a quick-release feature for easy panel removal. Hinges are color-matched to the exterior.

#### Removable Panels



Panels can be easily removed with the unique panel-release tab on the hinge. Release tabs are covered with a cap for a clean appearance. This release feature is ideal for transporting large units up stairs or to other hard-to-reach areas.

#### HARDWARE

##### Multi-Point Locking System



Frenchwood hinged patio doors have a multi-point locking system that combines hook bolts with a center deadbolt. This system provides added weathertightness and enhanced security.

##### Optional Corrosion-Resistant Hardware

Optional corrosion-resistant locking mechanism and hinges are available and recommended for applications within two miles of the coast and other harsh environments.\*

Lighthouse indicates differences from standard unit or optional upgrades.

\*Visit [andersenwindows.com/warranty](http://andersenwindows.com/warranty) for details.

\*\*Actual wood species is either Sapele or Sipo, both non-endangered species grown in Africa, with color and characteristics similar to Central American mahoganies.

†Flexacron® is a registered trademark of PPG Industries, Inc.



## FEATURES

### FRENCHWOOD® PATIO DOOR SIDELIGHTS

#### FRAME

Frame constructed with a wood core and a fiberglass exterior. This construction produces a rigid frame and a low-maintenance, durable exterior.

Wood members are treated with a water-repellent preservative for long-lasting protection and performance.

The interior wood jamb has an extension jamb kerf, making it easy to add interior extension jambs to match wall depth.

#### SILL

One-piece fiberglass design provides superior water management. The nonconductive fiberglass construction enhances energy performance, and its superior strength eliminates the need for a sill support.

Slip- and wear-resistant poly bead finish available in either neutral gray or dark bronze color.

Factory-applied drop-nose channel attachment is available for enhanced water performance. See "Common Features" for details.

#### GLASS

See "Common Features" for details.

#### PANEL

Panel stiles and rails are constructed of an engineered LVL core. This LVL core provides strength and helps prevent warping for consistent smooth operation. Interior panel surfaces are constructed from premium wood veneer available in pine, maple, oak, cherry, mahogany\*\* and vertical grain Douglas fir. All prefinished interior options use water-based paints and stains. The exterior of the wood panel is protected with a Flexacron® paint system; this stabilized polyester paint is electrostatically applied to penetrate all exterior surfaces for maximum protection and a lustrous, low-maintenance finish.

### FRENCHWOOD PATIO DOOR TRANSOMS

#### FRAME

Frame constructed with a wood core and a fiberglass exterior. This construction produces a rigid frame and a low-maintenance, durable exterior.

Wood members are treated with a water-repellent preservative for long-lasting protection and performance.

The interior wood jamb has an extension jamb kerf, making it easy to add interior extension jambs to match wall depth.

#### SASH

Available in direct-set or sash-set construction. Direct-set transoms have glass glazed directly into the frame and maximize glass area. Sash-set transoms feature a fixed sash and provide common sight lines with A-Series patio doors.

Frenchwood patio door transoms feature elegant lines that match the Frenchwood patio doors. Available in pine, maple, oak, cherry, mahogany\*\* and vertical grain Douglas fir. All prefinished interior options use water-based paints and stains.

#### GLASS

See "Common Features" for details.

## COMMON FEATURES

#### GLASS

Impact-resistant glass construction provides industry-leading energy performance, sound control and added security.

Panels are silicone bed glazed and finished with an interior wood glass stop.

Interior wood glass stops are secured using 1 1/2" (38) 16-gauge crown staples instead of nails. Silicone is also applied to the full perimeter of the glass on the interior side of the pane to add strength and stability.

A removable translucent film helps shield the glass from damage during delivery and construction and also simplifies finishing at the jobsite.

Obscure glass options are available, contact your Andersen supplier.

Consult local building codes for the glass most suitable to your area. High-performance options include:

- Low-E4® Impact-Resistant tempered glass
- Low-E4 HeatLock® Impact-Resistant tempered glass
- Low-E4 Sun Impact-Resistant tempered glass
- Low-E4 SmartSun™ Impact-Resistant tempered glass
- Low-E4 SmartSun HeatLock Impact-Resistant tempered glass

Standard Low-E4, Low-E4 HeatLock, Low-E4 Sun and Low-E4 SmartSun tempered glass options are available for doors with PG upgrades.

Monolithic laminated options include:

- Clear Monolithic SmartSun Impact-Resistant tempered glass
- Gray Monolithic SmartSun Impact-Resistant tempered glass

#### SILL

##### Performance Grade (PG) Upgrade Optional Drop-Nose Channel



A factory-applied, patented drop-nose channel is available when higher product performance is required. Drop-nose channel provides enhanced water performance without increasing interior sill height. Shown on a Frenchwood hinged inswing patio door. Details shown on page 125.

#### Drop-Nose Sill Cover



Drop-nose sill cover is designed to cover the sill gap between two joined units. Available in all sill colors.

#### TALLER HEIGHTS

A-Series Frenchwood patio doors and patio door sidelights are available in heights up to 9'-11 1/2" (3023).

\*Visit [andersenwindows.com/warranty](http://andersenwindows.com/warranty) for details.

\*\*Actual wood species is either Sapele or Sipo, both non-endangered species grown in Africa, with color and characteristics similar to Central American mahoganies.

†Flexacron® is a registered trademark of PPG Industries, Inc.

Dimensions in parentheses are in millimeters.

EXTERIOR & INTERIOR

EXTERIOR COLORS



INTERIOR WOOD SPECIES



FACTORY-FINISHED INTERIORS



Shown on pine. Available on pine, maple and oak only.  
Naturally occurring variations in grain, color and texture of wood make each window one of a kind. All wood interiors are unfinished unless a finish is specified.

INTERIOR PAINTED OPTIONS



Available on pine.  
Additional colors to match all 11 exterior colors are also available, contact your Andersen supplier.

HARDWARE Sold Separately\*\*



Bold name denotes finish shown.

HARDWARE FINISHES

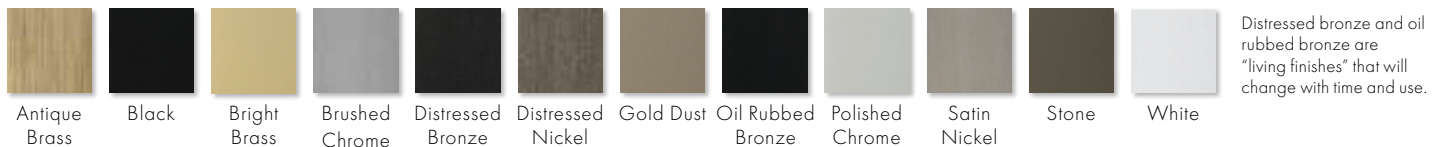

Distressed bronze and oil rubbed bronze are "living finishes" that will change with time and use.

FSB® HINGED PATIO DOOR HARDWARE

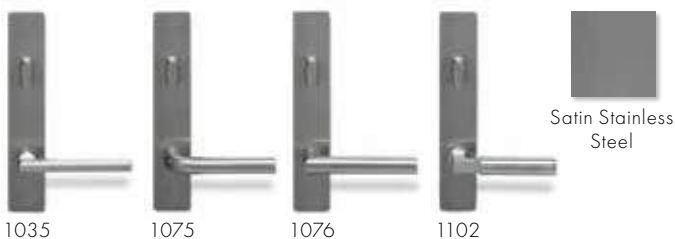

\*Actual wood species is either Sapele or Sipo, both non-endangered species grown in Africa, with color and characteristics similar to Central American mahoganies.  
\*\*Matching hinges available in most hardware finishes for inswing patio doors.  
Mix and match interior and exterior style and finish options are available, excludes FSB hardware.  
Bright brass and satin nickel finishes feature a 10-year limited warranty.  
Tribeca and Albany hardware are zinc diecast with powder-coated durable finish, other hardware is solid forged brass.  
Printing limitations prevent exact replication of colors and finishes.  
See your Andersen supplier for actual color and finish samples.  
"FSB" is a registered trademark of Franz Schneider Brakel GmbH & Co.

**ACCESSORIES** Sold Separately

**FRAME**

**Extension Jamb**

Available in pine, maple, oak, cherry, mahogany\* and vertical grain Douglas fir precut to fit the unit. Available in 1/16" (1.5) increments up to 7 1/8" (181) and can be prefinished to match the interior finish of the unit. This option is also available factory applied.

Interior extension jamba on inswing units will restrict the full opening of the door.

**Threshold for Frenchwood® Gliding and Hinged Inswing Patio Doors**



An oak or maple threshold is available for finishing the interior of the sill on Frenchwood gliding and hinged inswing patio doors.

**Sill Step for Frenchwood Hinged Outswing Patio Doors**

The Frenchwood hinged outswing door offers an optional oak or maple sill step. See page 125.

**Remodeler Sill Bracket for Frenchwood Gliding and Hinged Inswing Patio Doors**



Allows for easy installation in replacement applications with a finished interior floor. It fastens to the subfloor, and the sill snaps into the bracket, providing a secured structural installation.

**HARDWARE**

**Exterior Keyed Lock**



A six-pin exterior key cylinder lock is available for all patio doors in styles and finishes that coordinate with hardware. This lock allows the patio door to be locked and unlocked from the exterior. Gliding patio door lock shown.

**Auxiliary Foot Lock for Frenchwood Gliding Patio Doors**



Provides an extra measure of security when the door is in a locked position. Lock can be set so the door is fully closed or partially open to provide a secure venting position. Available in all hardware finishes.

**Handle Extension for Frenchwood Hinged Inswing and Outswing Patio Doors**

Extends interior door handle an additional 1" (25) from the door panel to accommodate interior blinds or shades. Kit includes one handle extender and spindle. A second extender may be added to the spindle to increase the length an additional 1" (25) to a 2" (51) total extension. Extenders are available in finishes that coordinate with hardware.

**Strike Plate Extensions for Frenchwood Hinged Inswing Patio Doors**

Antique brass, bright brass, brushed chrome, oil rubbed bronze, polished chrome and satin nickel strike plate extensions are available for the following wall depths: 5 1/4" (133), 6 3/8" (167) and 7 1/8" (181).

**Construction Hardware for Frenchwood Hinged Inswing and Outswing Patio Doors**



This hardware can be used to help secure the jobsite during the construction phase of the project. It features an undersized escutche on plate, which makes onsite finishing easier.

**Yale® Assure Lock® Keyless Lock**



Monitor, lock and unlock from anywhere with the Yale Assure Lock. The sleek key-free lock includes Bluetooth® technology for key-free unlocking and is compatible with Z-Wave® for integration with a wide range of smart home platforms. See page 9 for additional details.

**SECURITY SENSORS**

**VeriLock® Sensors\*\***

VeriLock sensors are available in five colors. See page 9 for details.

**Open/Closed Sensors**

Wireless open/closed sensors are available in four colors. See page 8 for details.

**GRILLES**

Grilles are available in a variety of configurations and widths. See page 15 for details.

**INSECT SCREENS**

All insect screens have a long-lasting† fiberglass mesh with a charcoal finish. Insect screen frames are color matched to the exterior of your door unless otherwise noted.

**Top-Hung Gliding and Gliding Insect Screens for Frenchwood Gliding and Hinged Inswing Patio Doors**

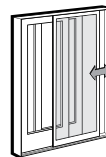

Patented square corner joints add considerable strength to the frame members. The insect screen is available in a conventional gliding or a premium top-hung gliding design. The conventional insect screen has bottom rollers with self-contained leveling adjusters. The premium top-hung insect screen has silicone-embedded glide hooks that hang from the top of the screen track, allowing it to glide smoothly and effortlessly. Alignment rollers on the bottom of the insect screen keep it in place on the track while the perimeter bug seal helps ensure insects stay on the outside.

**Retractable Insect Screen for Frenchwood Gliding Patio Doors**

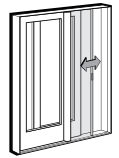

The retractable insect screen is installed on the exterior of the door and opens side-to-side across the width of the opening. When the insect screen is not in use, it neatly retracts into a small canister mounted on the exterior of the door. Available for two-panel doors. Please note, retractable screen track reduces clear opening height by 1" (25).

**Retractable Insect Screen for Frenchwood Hinged Outswing Patio Doors**

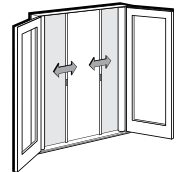

The retractable insect screen is installed on the interior of the door across the width of the opening. When the insect screen is not in use, it neatly retracts into small canisters mounted on each side of the door. Retractable insect screens are available for single-panel and two-panel doors with white, gold dust, pine, oak and maple finishes and six stains to match the interior of your door. Please note, retractable screen track reduces clear opening height by 1" (25).

**Hinged Insect Screen for Frenchwood Hinged Inswing Patio Doors**

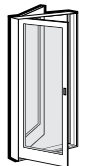

Available for single-panel doors.

**Double-Hinged Insect Screen for Frenchwood Hinged Inswing Patio Doors**

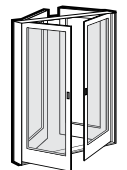

Available for two-panel jamb-hinged doors.

**GLASS**

**Andersen® Art Glass**

Available for PG upgrade units only. Andersen art glass panels come in a variety of original patterns. Visit [andersenwindows.com/artglass](http://andersenwindows.com/artglass) for details and pattern information.

**EXTERIOR TRIM**

This product is available with Andersen Exterior Trim. See pages 141-147 for details.

\*Actual wood species is either Sapele or Sipo, both non-endangered species grown in Africa with color and characteristics similar to Central American mahoganies.

\*\*VeriLock is not compatible with Yale or FSB® hardware.

†Visit [andersenwindows.com/warranty](http://andersenwindows.com/warranty) for details.

Dimensions in parentheses are in millimeters.

## Table of Frenchwood® Gliding Patio Door Sizes

Scale 1/8" (3) = 1'-0" (305) – 1:96

Door Dimension	2'-8 3/8" (822)	4'-11 1/4" (1505)	4'-11 1/4" (1505)	9'-9" (2972)	9'-9" (2972)
<b>Minimum Rough Opening</b>	2'-9" (838)	5'-0" (1524)	5'-0" (1524)	9'-10" (2997)	9'-10" (2997)
Unobstructed Glass (single panel only)	21 1/8" (537)	21 1/8" (537)	21 1/8" (537)	21 1/8" (537)   52" (1321)   21 1/8" (537)	21 1/8" (537)
4 heights					
<b>1 FWGD</b>	2968S	5068L	5068R	91068-3	91068-4
<b>2 FWGD</b>	29611S	50611L	50611R	910611-3	910611-4
<b>3 FWGD</b>	2980S	5080L	5080R	91080-3	91080-4
<b>4 FWGD</b>	29100S	50100L	50100R	910100-3	910100-4



**Custom-size patio doors are available in 1/8" (3) increments.**  
See pages 138-139 for custom sizes, specifications and information on shipping patio doors greater than 95 1/2" (2426).

Door Dimension	3'-2 3/8" (974)	5'-11 1/4" (1810)	5'-11 1/4" (1810)	11'-9" (3581)	11'-9" (3581)
<b>Minimum Rough Opening</b>	3'-3" (991)	6'-0" (1829)	6'-0" (1829)	11'-10" (3606)	11'-10" (3600)
Unobstructed Glass (single panel only)	27 1/8" (689)	27 1/8" (689)	27 1/8" (689)	27 1/8" (689)   64" (1626)   27 1/8" (689)	27 1/8" (689)
4 heights					
<b>1 FWGD</b>	3368S	6068L	6068R	111068-3	111068-4
<b>2 FWGD</b>	33611S	60611L	60611R	1110611-3	1110611-4
<b>3 FWGD</b>	3380S	6080L	6080R	111080-3	111080-4
<b>4 FWGD</b>	33100S	60100L	60100R	1110100-3	1110100-4

Door Dimension	3'-8 3/8" (1126)	6'-11 1/4" (2114)	6'-11 1/4" (2114)
<b>Minimum Rough Opening</b>	3'-9" (1067)	7'-0" (2133)	7'-0" (2133)
Unobstructed Glass (single panel only)	33 1/8" (841)	33 1/8" (841)	33 1/8" (841)
4 heights			
<b>1 FWGD</b>	3968S	7068L	7068R
<b>2 FWGD</b>	39611S	70611L	70611R
<b>3 FWGD</b>	3980S	7080L	7080
<b>4 FWGD</b>	39100S	70100L	70100R

Arrows indicate direction of panel operation as viewed from the exterior. Stationary (S) doors can be used as an individual patio door or as a sidelight. Single-panel patio doors are factory-assembled. Two-panel doors up to 95 1/2" (2426) in height are available unassembled or can be factory-assembled and will arrive at the jobsite ready to install. Two-panel doors greater than 95 1/2" (2426) in height and three- and four-panel doors are available unassembled only.

Details shown on pages 112-113. Grille patterns shown on page 123.

Door Dimension	4'-2 3/8" (1279)	7'-11 1/4" (2419)	7'-11 1/4" (2419)	15'-9" (4801)
<b>Minimum Rough Opening</b>	4'-3" (1295)	8'-0" (2438)	8'-0" (2438)	15'-10" (4826)
Unobstructed Glass (single panel only)	39 1/8" (994)	39 1/8" (994)	39 1/8" (994)	39 1/8" (994)
4 heights				
<b>1 FWGD</b>	4368S	8068L	8068R	151068-4
<b>2 FWGD</b>	43611S	80611L	80611R	1510611-4
<b>3 FWGD</b>	4380S	8080L	8080R	151080-4
<b>4 FWGD</b>	43100S	80100L	80100R	1510100-4

\* "Door Dimension" always refers to outside frame to frame dimension.  
\* "Minimum Rough Opening" dimensions may need to be increased to allow for use of building wraps, flashing, sill panning, brackets, fasteners or other items. See installation information on page 170.  
\* Dimensions in parentheses are in millimeters.



**Four Patio Door Heights**

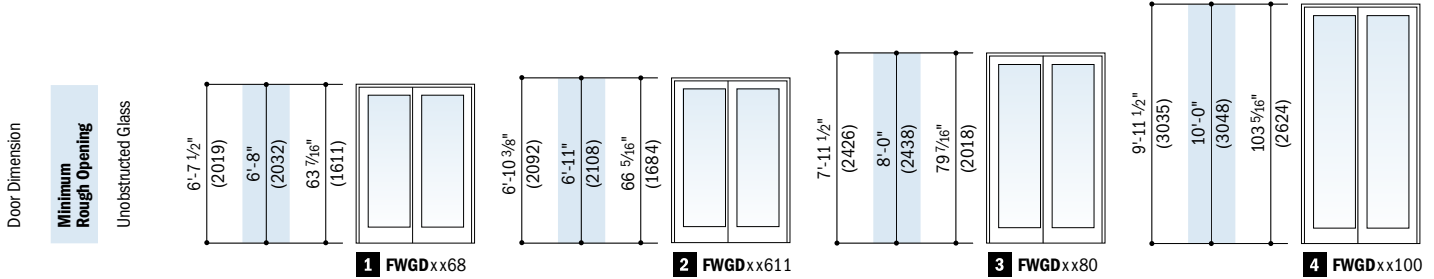

**Frenchwood® Gliding Patio Door Opening and Area Specifications**

Door Number	Number of Panels in Open Position	Clear Opening Area Sq. Ft./ (m <sup>2</sup> )	Clear Opening in Full Open Position		Glass Area Sq. Ft./ (m <sup>2</sup> )	Vent Area Sq. Ft./ (m <sup>2</sup> )	Overall Door Area Sq. Ft./ (m <sup>2</sup> )
			Width Inches/(mm)	Height Inches/(mm)			
FWGD5068	1	11.16 (1.04)	21 1/4" (540)	75 1/2" (1918)	18.61 (1.73)	11.16 (1.04)	32.71 (3.04)
FWGD6068	1	14.31 (1.33)	27 1/4" (692)	75 1/2" (1918)	23.90 (2.22)	14.31 (1.33)	39.34 (3.65)
FWGD7068	1	17.45 (1.62)	33 1/4" (845)	75 1/2" (1918)	29.19 (2.71)	17.45 (1.62)	45.96 (4.27)
FWGD8068	1	20.60 (1.91)	39 1/4" (997)	75 1/2" (1918)	34.47 (3.20)	20.60 (1.91)	52.59 (4.89)
FWGD91068-4	2	22.60 (2.10)	43 1/16" (1094)	75 1/2" (1918)	37.22 (3.46)	22.60 (2.10)	64.59 (6.00)
FWGD91068-3	1	11.16 (1.04)	21 1/4" (540)	75 1/2" (1918)	41.51 (3.86)	11.16 (1.04)	64.59 (6.00)
FWGD91068-3	2	22.32 (2.08)	21 1/4" (540)	75 1/2" (1918)	41.51 (3.86)	22.32 (2.08)	64.59 (6.00)
FWGD111068-4	2	28.89 (2.68)	55 1/16" (1399)	75 1/2" (1918)	47.80 (4.44)	28.89 (2.68)	77.84 (7.23)
FWGD111068-3	1	14.31 (1.33)	27 1/4" (692)	75 1/2" (1918)	52.08 (4.84)	14.31 (1.33)	77.84 (7.23)
FWGD111068-3	2	28.62 (2.66)	27 1/4" (692)	75 1/2" (1918)	52.08 (4.84)	28.62 (2.66)	77.84 (7.23)
FWGD151068-4	2	41.49 (3.86)	79 1/16" (2008)	75 1/2" (1918)	68.94 (6.40)	41.49 (3.85)	104.34 (9.69)
FWGD50611	1	11.58 (1.08)	21 1/4" (540)	78 1/16" (1992)	19.46 (1.81)	11.58 (1.08)	33.89 (3.15)
FWGD60611	1	14.85 (1.38)	27 1/4" (692)	78 1/16" (1992)	24.98 (2.32)	14.85 (1.38)	40.76 (3.79)
FWGD70611	1	18.12 (1.68)	33 1/4" (845)	78 1/16" (1992)	30.51 (2.83)	18.12 (1.68)	47.62 (4.42)
FWGD80611	1	21.39 (1.99)	39 1/4" (997)	78 1/16" (1992)	36.03 (3.35)	21.39 (1.99)	54.49 (5.06)
FWGD910611-4	2	23.46 (2.18)	43 1/16" (1094)	78 1/16" (1992)	38.91 (3.61)	23.46 (2.18)	66.93 (6.22)
FWGD910611-3	1	11.58 (1.08)	21 1/4" (540)	78 1/16" (1992)	43.39 (4.03)	11.58 (1.08)	66.93 (6.22)
FWGD910611-3	2	23.16 (2.16)	21 1/4" (540)	78 1/16" (1992)	43.39 (4.03)	23.16 (2.16)	66.93 (6.22)
FWGD1110611-4	2	29.99 (2.79)	55 1/16" (1399)	78 1/16" (1992)	49.96 (4.64)	29.99 (2.79)	80.66 (7.49)
FWGD1110611-3	1	14.85 (1.38)	27 1/4" (692)	78 1/16" (1992)	54.44 (5.06)	14.85 (1.38)	80.66 (7.49)
FWGD1110611-3	2	29.70 (2.76)	27 1/4" (692)	78 1/16" (1992)	54.44 (5.06)	29.70 (2.76)	80.66 (7.49)
FWGD1510611-4	2	43.07 (4.00)	79 1/16" (2008)	78 1/16" (1992)	72.07 (6.70)	43.07 (4.00)	108.12 (10.04)
FWGD5080	1	13.52 (1.26)	21 1/4" (540)	91 1/2" (2324)	23.31 (2.17)	13.52 (1.26)	39.29 (3.65)
FWGD6080	1	17.33 (1.61)	27 1/4" (692)	91 1/2" (2324)	29.93 (2.78)	17.33 (1.61)	47.25 (4.39)
FWGD7080	1	21.15 (1.96)	33 1/4" (845)	91 1/2" (2324)	36.55 (3.40)	21.15 (1.96)	55.21 (5.13)
FWGD8080	1	24.96 (2.32)	39 1/4" (997)	91 1/2" (2324)	43.17 (4.01)	24.96 (2.32)	63.17 (5.87)
FWGD91080-4	2	27.38 (2.54)	43 1/16" (1094)	91 1/2" (2324)	46.61 (4.33)	27.38 (2.54)	77.59 (7.21)
FWGD91080-3	1	13.52 (1.26)	21 1/4" (540)	91 1/2" (2324)	51.97 (4.83)	13.52 (1.26)	77.59 (7.21)
FWGD91080-3	2	27.04 (2.52)	21 1/4" (540)	91 1/2" (2324)	51.97 (4.83)	27.04 (2.52)	77.59 (7.21)
FWGD111080-4	2	35.01 (3.25)	55 1/16" (1399)	91 1/2" (2324)	59.85 (5.56)	35.01 (3.25)	93.51 (8.69)
FWGD111080-3	1	17.33 (1.61)	27 1/4" (692)	91 1/2" (2324)	65.21 (6.06)	17.33 (1.61)	93.51 (8.69)
FWGD111080-3	2	34.66 (3.22)	27 1/4" (692)	91 1/2" (2324)	65.21 (6.06)	34.66 (3.22)	93.51 (8.69)
FWGD151080-4	2	50.27 (4.67)	79 1/16" (2008)	91 1/2" (2324)	86.33 (8.02)	50.27 (4.67)	125.34 (11.64)
FWGD50100	1	17.04 (1.58)	21 1/4" (540)	115 1/2" (2934)	30.35 (2.71)	17.04 (1.58)	49.17 (4.57)
FWGD60100	1	21.86 (2.03)	27 1/4" (692)	115 1/2" (2934)	38.97 (3.47)	21.86 (2.03)	59.13 (5.49)
FWGD70100	1	26.67 (2.48)	33 1/4" (845)	115 1/2" (2934)	47.59 (4.24)	26.67 (2.48)	69.09 (6.42)
FWGD80100	1	31.48 (2.93)	39 1/4" (997)	115 1/2" (2934)	56.21 (5.01)	31.48 (2.93)	79.04 (7.34)
FWGD910100-4	2	34.54 (3.21)	43 1/16" (1094)	115 1/2" (2934)	60.69 (5.41)	34.54 (3.21)	97.09 (9.02)
FWGD910100-3	1	17.04 (1.58)	21 1/4" (540)	115 1/2" (2934)	67.68 (6.03)	17.04 (1.58)	97.09 (9.02)
FWGD910100-3	2	34.08 (3.16)	21 1/4" (540)	115 1/2" (2934)	67.68 (6.03)	34.08 (3.16)	97.09 (9.02)
FWGD1110100-4	2	44.16 (4.10)	55 1/16" (1399)	115 1/2" (2934)	77.93 (6.95)	44.16 (4.10)	117.01 (10.87)
FWGD1110100-3	1	21.86 (2.03)	27 1/4" (692)	115 1/2" (2934)	84.92 (7.57)	21.86 (2.03)	117.01 (10.87)
FWGD1110100-3	2	43.72 (4.06)	27 1/4" (692)	115 1/2" (2934)	84.92 (7.57)	43.72 (4.06)	117.01 (10.87)
FWGD1510100-4	2	63.41 (5.89)	79 1/16" (2008)	115 1/2" (2934)	112.41 (10.02)	63.41 (5.89)	156.84 (14.57)

\*Dimensions in parentheses are in millimeters or square meters.

**Stationary Frenchwood® Gliding Patio Door Area Specifications**

Door Number	Glass Area Sq. Ft./ (m <sup>2</sup> )	Overall Door Area Sq. Ft./ (m <sup>2</sup> )
FWGD2968S	9.31 (0.86)	17.86 (1.66)
FWGD3368S	11.95 (1.11)	21.17 (1.97)
FWGD3968S	14.59 (1.36)	24.48 (2.27)
FWGD4368S	17.24 (1.60)	27.79 (2.58)
FWGD29611S	9.73 (0.90)	18.50 (1.72)
FWGD33611S	12.49 (1.16)	21.93 (2.04)
FWGD39611S	15.25 (1.42)	25.37 (2.36)
FWGD43611S	18.02 (1.67)	28.80 (2.68)
FWGD2980S	11.65 (1.08)	21.45 (1.99)
FWGD3380S	14.96 (1.39)	21.94 (2.04)
FWGD3980S	18.27 (1.70)	29.41 (2.73)
FWGD4380S	21.58 (2.00)	33.39 (3.10)
FWGD29100S	15.17 (1.41)	26.84 (2.49)
FWGD33100S	19.48 (1.81)	31.82 (2.96)
FWGD39100S	23.79 (2.21)	36.80 (3.42)
FWGD43100S	28.10 (2.61)	41.78 (3.88)

\*Dimensions in parentheses are in square meters.

## Frenchwood® Gliding Patio Door Details

Scale 1 1/2" (38) = 1'-0" (305) – 1:8

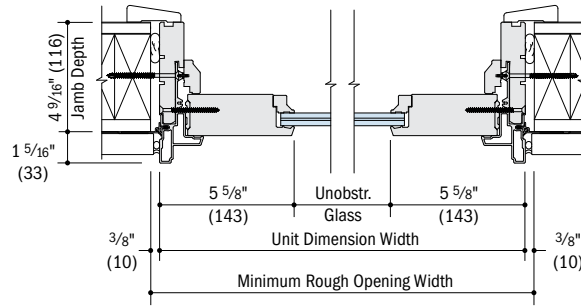

**Horizontal Section – Stationary**  
Monolithic SmartSun™ Impact-Resistant Glass

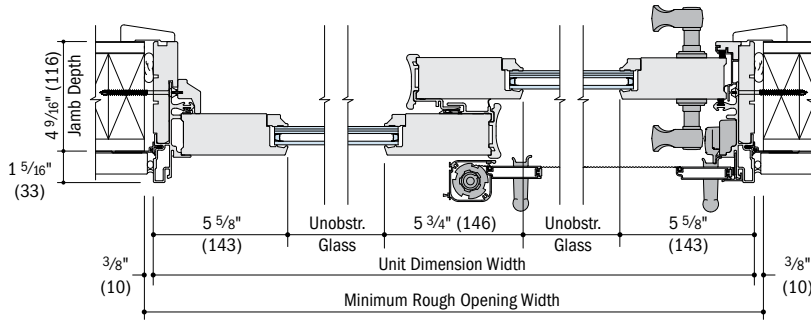

**Horizontal Section – Two-Panel**  
Retractable Insect Screen – Low-E4™ Impact-Resistant Glass

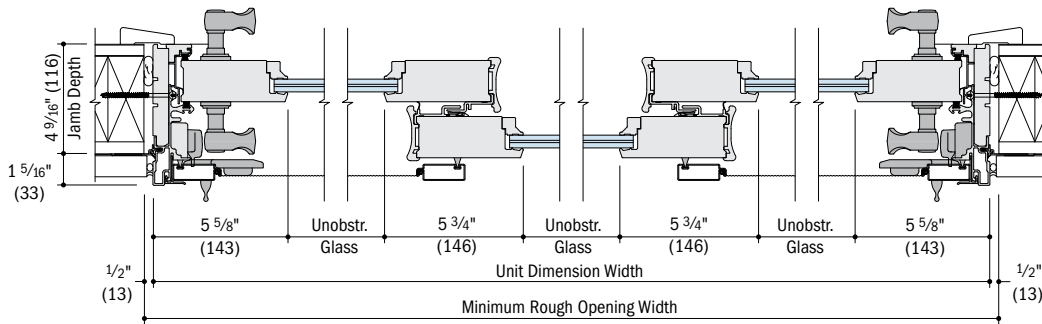

**Horizontal Section – Three-Panel**  
Top-Hung® Gliding or Gliding Insect Screen – Monolithic SmartSun™ Impact-Resistant Glass

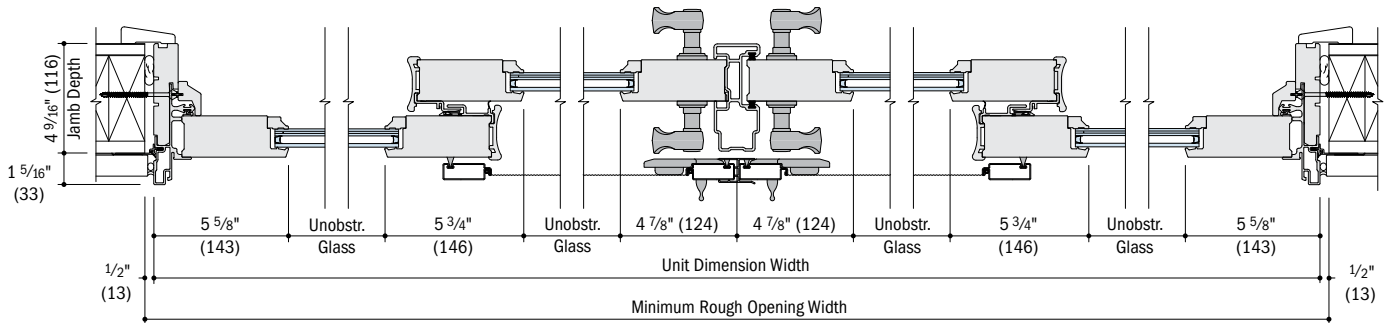

**Horizontal Section – Four-Panel**  
Top-Hung® Gliding or Gliding Insect Screen – Low-E4™ Impact-Resistant Glass

- 4 9/16" (116) jamb depth measurement is from back side of installation flange.
- Light-colored areas are parts included with door. Dark-colored areas are additional Andersen® parts required to complete door assembly as shown.
- Dimensions in parentheses are in millimeters.
- **Minimum rough opening dimensions may need to be increased to allow for use of building wraps, flashing, sill panning, brackets, fasteners or other items. See installation information on page 170.**
- Details are for illustration only and are not intended to represent product installation methods or materials. Refer to product installation guides at andersenwindows.com.
- Top-hung gliding insect screens are not available for door heights greater than 95 1/2" (2426).

**Frenchwood® Gliding Patio Door Details**

Scale 1 1/2" (38) = 1'-0" (305) – 1:8

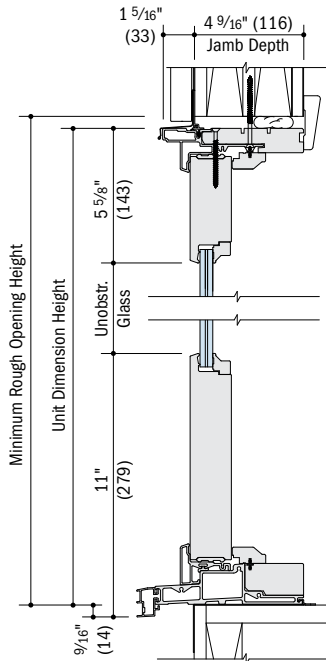

**Vertical Section – Stationary**  
Monolithic SmartSun™ Impact-Resistant Glass

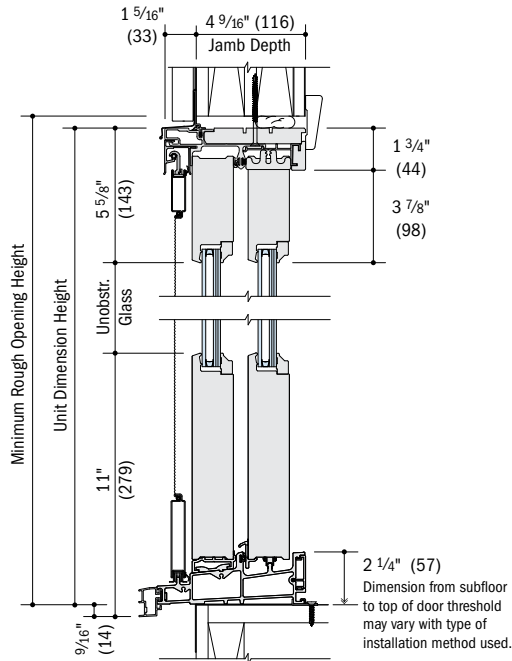

**Vertical Section – Operating**  
Top-Hung\* Gliding Insect Screen – Low-E4\* Impact-Resistant Glass

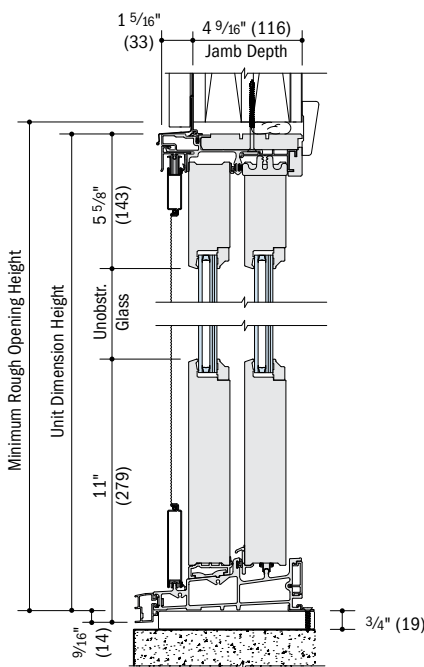

**Vertical Section – Operating**  
Gliding Insect Screen – Low-E4\* Impact-Resistant Glass

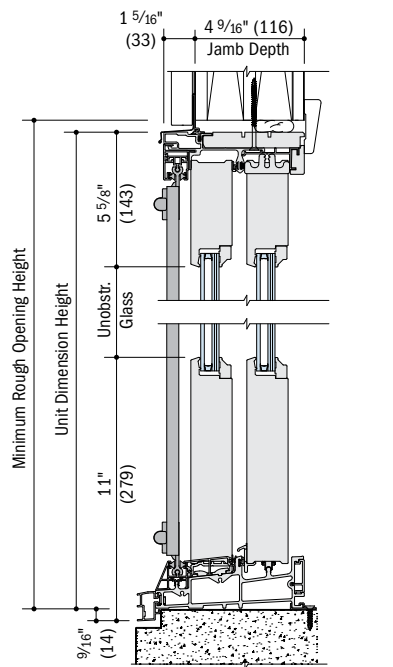

**Vertical Section – Operating**  
Retractable Insect Screen – Low-E4\* Impact-Resistant Glass

**Remodeler Sill Bracket**

Optional remodeler sill bracket is available for installations with an existing finished interior floor.

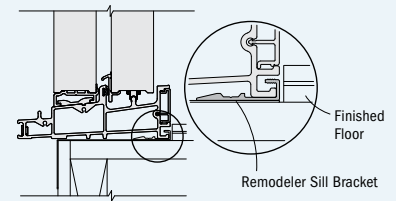

**Drop-Nose Channel**

Optional drop-nose channel is available when higher product performance is required. Wood and concrete installations shown.

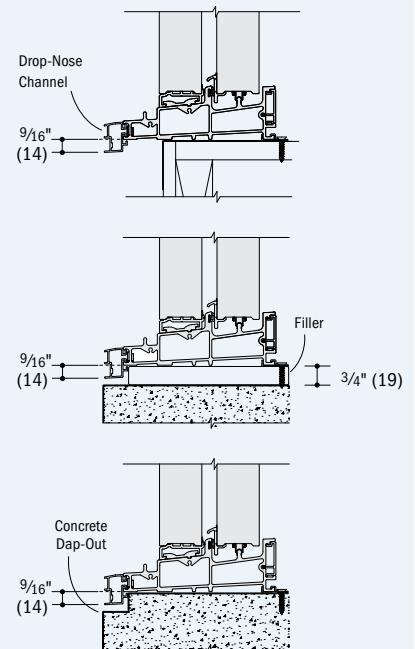

See pages 134-137 for horizontal and vertical joining details.

- 4 9/16" (116) jamb depth measurement is from back side of installation flange.
- Light-colored areas are parts included with door. Dark-colored areas are additional Andersen® parts required to complete door assembly as shown.
- Dimensions in parentheses are in millimeters.
- **Minimum rough opening dimensions may need to be increased to allow for use of building wraps, flashing, sill panning, brackets, fasteners or other items. See installation information on page 170.**
- Details are for illustration only and are not intended to represent product installation methods or materials. Refer to product installation guides at andersenwindows.com.
- Top-hung gliding insect screens are not available for door heights greater than 95 1/2" (2426).

A-Series Frenchwood® Gliding Patio Doors

## Table of Frenchwood® Hinged Inswing Patio Door Sizes

Scale 1/8" (3) = 1'-0" (305) – 1:96

Notes on the next page also apply to this page.

Door Dimension	2'-0 1/8" (612)	3'-11 1/4" (1200)	3'-11 1/4" (1200)	2'-6 1/8" (764)	2'-6 1/8" (764)	2'-6 1/8" (764)	4'-11 1/4" (1505)	4'-11 1/4" (1505)	4'-11 1/4" (1505)
<b>Minimum Rough Opening</b>	2'-1" (634)	4'-0" (1219)	4'-0" (1219)	2'-7" (787)	2'-7" (787)	2'-7" (787)	5'-0" (1524)	5'-0" (1524)	5'-0" (1524)
Unobstructed Glass (single panel only)	12 7/8" (327)	12 7/8" (327)	12 7/8" (327)	18 7/8" (479)	18 7/8" (479)	18 7/8" (479)	18 7/8" (479)	18 7/8" (479)	18 7/8" (479)
4 heights									
<b>1 FWHID</b>	2168S*	4068SS	4068APLR/4068PALR	2768S	2768AR	2768AL	5068SS	5068ASR	5068ASL
<b>2 FWHID</b>	21611S*	40611SS	40611APLR/40611PALR	27611S	27611AR	27611AL	50611SS	50611ASR	50611ASL
<b>3 FWHID</b>	2180S*	4080SS	4080APLR/4080PALR	2780S	2780AR	2780AL	5080SS	5080ASR	5080ASL
<b>4 FWHID</b>	21100S*		40100APLR/40100PALR	27100S	27100AR	27100AL			
Door Dimension	2'-8 1/8" (815)	2'-8 1/8" (815)	2'-8 1/8" (815)	5'-3 1/4" (1607)	5'-3 1/4" (1607)	5'-3 1/4" (1607)	5'-3 1/4" (1607)	5'-3 1/4" (1607)	5'-3 1/4" (1607)
<b>Minimum Rough Opening</b>	2'-9" (838)	2'-9" (838)	2'-9" (838)	5'-4" (1626)	5'-4" (1626)	5'-4" (1626)	5'-4" (1626)	5'-4" (1626)	5'-4" (1626)
Unobstructed Glass (single panel only)	20 7/8" (530)	20 7/8" (530)	20 7/8" (530)	20 7/8" (530)	20 7/8" (530)	20 7/8" (530)	20 7/8" (530)	20 7/8" (530)	20 7/8" (530)
4 heights									
<b>1 FWHID</b>	2968S	2968AR	2968AL	5468SS	5468ASR	5468ASL	5468SAR	5468SAL	5468APLR/5468PALR
<b>2 FWHID</b>	29611S	29611AR	29611AL	54611SS	54611ASR	54611ASL	54611SAR	54611SAL	54611APLR/54611PALR
<b>3 FWHID</b>	2980S	2980AR	2980AL	5480SS	5480ASR	5480ASL	5480SAR	5480SAL	5480APLR/5480PALR
<b>4 FWHID</b>	29100S	29100AR	29100AL						54100APLR/54100PALR
Door Dimension	3'-0 1/8" (917)	3'-0 1/8" (917)	3'-0 1/8" (917)	5'-11 1/4" (1810)	5'-11 1/4" (1810)	5'-11 1/4" (1810)	5'-11 1/4" (1810)	5'-11 1/4" (1810)	5'-11 1/4" (1810)
<b>Minimum Rough Opening</b>	3'-1" (940)	3'-1" (940)	3'-1" (940)	6'-0" (1829)	6'-0" (1829)	6'-0" (1829)	6'-0" (1829)	6'-0" (1829)	6'-0" (1829)
Unobstructed Glass (single panel only)	24 7/8" (632)	24 7/8" (632)	24 7/8" (632)	24 7/8" (632)	24 7/8" (632)	24 7/8" (632)	24 7/8" (632)	24 7/8" (632)	24 7/8" (632)
4 heights									
<b>1 FWHID</b>	3168S	3168AR	3168AL	6068SS	6068ASR	6068ASL	6068SAR	6068SAL	6068APLR/6068PALR
<b>2 FWHID</b>	31611S	31611AR	31611AL	60611SS	60611ASR	60611ASL	60611SAR	60611SAL	60611APLR/60611PALR
<b>3 FWHID</b>	3180S	3180AR	3180AL	6080SS	6080ASR	6080ASL	6080SAR	6080SAL	6080APLR/6080PALR
<b>4 FWHID</b>	31100S	31100AR	31100AL						60100APLR/60100PALR
Door Dimension	3'-2 1/8" (968)	3'-2 1/8" (968)	3'-2 1/8" (968)	6'-3 1/4" (1911)	6'-3 1/4" (1911)	6'-3 1/4" (1911)	6'-3 1/4" (1911)	6'-3 1/4" (1911)	6'-3 1/4" (1911)
<b>Minimum Rough Opening</b>	3'-3" (991)	3'-3" (991)	3'-3" (991)	6'-4" (1930)	6'-4" (1930)	6'-4" (1930)	6'-4" (1930)	6'-4" (1930)	6'-4" (1930)
Unobstructed Glass (single panel only)	26 7/8" (683)	26 7/8" (683)	26 7/8" (683)	26 7/8" (683)	26 7/8" (683)	26 7/8" (683)	26 7/8" (683)	26 7/8" (683)	26 7/8" (683)
4 heights									
<b>1 FWHID</b>	3368S	3368AR	3368AL	6468SS	6468ASR	6468ASL	6468SAR	6468SAL	6468APLR/6468PALR
<b>2 FWHID</b>	33611S	33611AR	33611AL	64611SS	64611ASR	64611ASL	64611SAR	64611SAL	64611APLR/64611PALR
<b>3 FWHID</b>	3380S	3380AR	3380AL	6480SS	6480ASR	6480ASL	6480SAR	6480SAL	6480APLR/6480PALR
<b>4 FWHID</b>	33100S	33100AR	33100AL						64100APLR/64100PALR

4'-11 1/4" (1505)	4'-11 1/4" (1505)	4'-11 1/4" (1505)
5'-0" (1524)	5'-0" (1524)	5'-0" (1524)
18 7/8" (479)	18 7/8" (479)	18 7/8" (479)

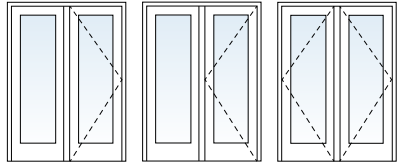

5068SAR  
50611SAR  
5080SAR

5068SAL  
50611SAL  
5080SAL

5068APLR/5068PALR  
50611APLR/50611PALR  
5080APLR/5080PALR  
50100APLR/50100PALR



**Custom-size doors are available in 1/8" (3) increments.** See pages 138-139 for custom sizes, specifications and information on shipping patio doors greater than 95 1/2" (2426).

Inswing doors are available in both 4 9/16" (116) and 6 9/16" (167) base jamb depths.

Stationary (S) patio doors can be used as an individual patio door or as a sidelight.

Two-panel doors greater than 95 1/2" (2426) in height are available unassembled only.

Details shown on pages 117-119. Grille patterns shown on page 123.

### Patio Door Heights

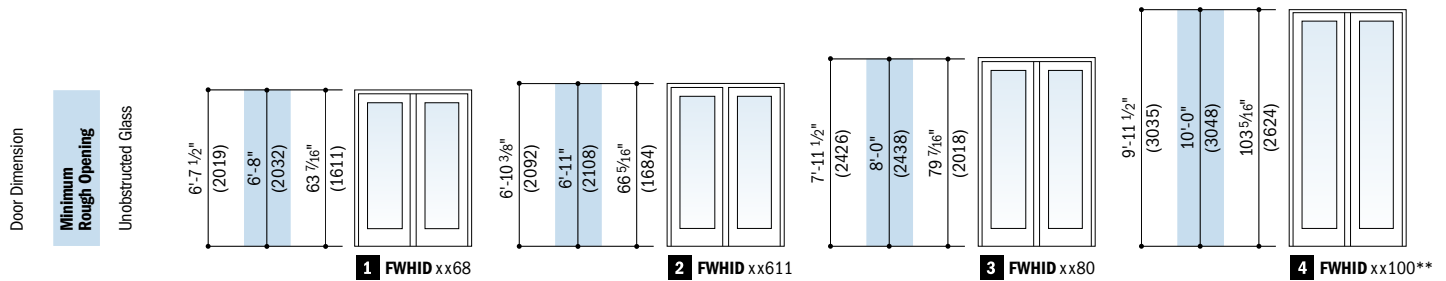

### Order Designation Description

Viewed from the exterior.

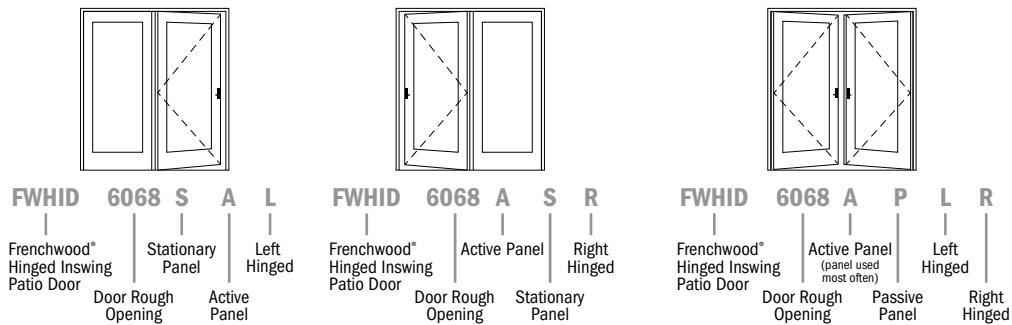

\* "Door Dimension" always refers to outside frame to frame dimension.

\*\* "Minimum Rough Opening" dimensions may need to be increased to allow for use of building wraps, flashing, sill panning, brackets, fasteners or other items. See installation information on page 170.

• Dimensions in parentheses are in millimeters.

\* Active left- and right-hinged patio doors also available. Contact your Andersen supplier for more information.

\*\* Single-panel and two-panel AP/PA doors only. SS, ASR, SAS, SAR and SAL configurations are not available in 119 1/2" (3035) heights or in custom heights greater than 95 1/2" (2426).

**Frenchwood® Hinged Inswing Patio Door Opening and Area Specifications**

Door Number	Number of Panels in Open Position*	Clear Opening Area Sq. Ft./ (m <sup>2</sup> )	Clear Opening Maximums			Glass Area Sq. Ft./ (m <sup>2</sup> )	Vent Area Sq. Ft./ (m <sup>2</sup> )	Overall Door Area Sq. Ft./ (m <sup>2</sup> )
			90° Open Position Width Inches/(mm)	Full Open Position Width Inches/(mm)	Height Inches/(mm)			
<b>FWHID2168S**</b>	1	10.43 (0.97)	18 5/16" (465)	20" (508)	75 1/2" (1918)	5.67 (0.53)	10.43 (0.97)	13.30 (1.24)
<b>FWHID2768</b>	1	13.57 (1.26)	24 5/16" (618)	26" (660)	75 1/2" (1918)	8.31 (0.77)	13.57 (1.26)	16.61 (1.54)
<b>FWHID2968</b>	1	14.62 (1.36)	26 5/16" (668)	28" (711)	75 1/2" (1918)	9.20 (0.85)	14.62 (1.36)	17.72 (1.65)
<b>FWHID3168</b>	1	16.71 (1.55)	30 5/16" (770)	32" (813)	75 1/2" (1918)	10.96 (1.02)	16.71 (1.55)	19.93 (1.85)
<b>FWHID3368</b>	1	17.75 (1.65)	32 5/16" (821)	34" (864)	75 1/2" (1918)	11.84 (1.10)	17.75 (1.65)	21.03 (1.95)
<b>FWHID4068</b>	2	22.54 (2.09)	39 3/4" (1009)	43 1/8" (1095)	75 1/2" (1918)	11.34 (1.05)	22.54 (2.09)	26.09 (2.42)
<b>FWHID4068</b>	1	10.43 (0.97)	18 5/16" (465)	20" (508)	75 1/2" (1918)	11.34 (1.05)	10.43 (0.97)	26.09 (2.42)
<b>FWHID5068</b>	1 AS/SA	13.57 (1.26)	24 5/16" (618)	26" (660)	75 1/2" (1918)	16.63 (1.54)	13.57 (1.26)	32.71 (3.04)
<b>FWHID5068</b>	2 AP/PA	28.81 (2.68)	51 3/4" (1314)	55 1/8" (1400)	75 1/2" (1918)	16.63 (1.54)	28.81 (2.68)	32.71 (3.04)
<b>FWHID5068</b>	1 AP/PA	13.57 (1.26)	24 5/16" (618)	26" (660)	75 1/2" (1918)	16.63 (1.54)	13.57 (1.26)	32.71 (3.04)
<b>FWHID5468</b>	1 AS/SA	14.62 (1.36)	26 5/16" (668)	28" (711)	75 1/2" (1918)	18.39 (1.71)	14.62 (1.36)	34.92 (3.24)
<b>FWHID5468</b>	2 AP/PA	30.90 (2.87)	55 3/4" (1416)	59 1/8" (1502)	75 1/2" (1918)	18.39 (1.71)	30.90 (2.87)	34.92 (3.24)
<b>FWHID5468</b>	1 AP/PA	14.61 (1.36)	26 5/16" (668)	28" (711)	75 1/2" (1918)	18.39 (1.71)	14.61 (1.36)	34.92 (3.24)
<b>FWHID6068</b>	1 AS/SA	16.71 (1.55)	30 5/16" (770)	32" (813)	75 1/2" (1918)	21.92 (2.04)	16.71 (1.55)	39.34 (3.65)
<b>FWHID6068</b>	2 AP/PA	35.08 (3.26)	63 3/4" (1619)	67 1/8" (1705)	75 1/2" (1918)	21.92 (2.04)	35.08 (3.26)	39.34 (3.65)
<b>FWHID6068</b>	1 AP/PA	16.71 (1.55)	30 5/16" (770)	32" (813)	75 1/2" (1918)	21.92 (2.04)	16.71 (1.55)	39.34 (3.65)
<b>FWHID6468</b>	1 AS/SA	17.75 (1.65)	32 5/16" (821)	34" (864)	75 1/2" (1918)	23.68 (2.20)	17.75 (1.65)	41.54 (3.86)
<b>FWHID6468</b>	2 AP/PA	37.17 (3.45)	67 3/4" (1720)	71 1/8" (1806)	75 1/2" (1918)	23.68 (2.20)	37.17 (3.45)	41.54 (3.86)
<b>FWHID6468</b>	1 AP/PA	17.75 (1.65)	32 5/16" (821)	34" (864)	75 1/2" (1918)	23.68 (2.20)	17.75 (1.65)	41.54 (3.86)
<b>FWHID21611S**</b>	1	10.83 (1.01)	18 5/16" (465)	20" (508)	78 1/8" (1984)	5.93 (0.55)	10.83 (1.01)	13.78 (1.28)
<b>FWHID27611</b>	1	14.09 (1.31)	24 5/16" (618)	26" (660)	78 1/8" (1984)	8.69 (0.81)	14.09 (1.31)	17.22 (1.60)
<b>FWHID29611</b>	1	15.17 (1.41)	26 5/16" (668)	28" (711)	78 1/8" (1984)	9.61 (0.89)	15.17 (1.41)	18.36 (1.71)
<b>FWHID31611</b>	1	17.34 (1.61)	30 5/16" (770)	32" (813)	78 1/8" (1984)	11.45 (1.06)	17.34 (1.61)	20.65 (1.92)
<b>FWHID33611</b>	1	18.43 (1.71)	32 5/16" (821)	34" (864)	78 1/8" (1984)	12.38 (1.15)	18.43 (1.71)	21.79 (2.02)
<b>FWHID40611</b>	2	23.40 (2.17)	39 3/4" (1009)	43 1/8" (1095)	78 1/8" (1984)	11.86 (1.10)	23.40 (2.17)	27.03 (2.51)
<b>FWHID40611</b>	1	10.83 (1.01)	18 5/16" (465)	20" (508)	78 1/8" (1984)	11.86 (1.10)	10.83 (1.01)	27.03 (2.51)
<b>FWHID50611</b>	1 AS/SA	14.09 (1.31)	24 5/16" (618)	26" (660)	78 1/8" (1984)	17.38 (1.61)	14.09 (1.31)	33.89 (3.15)
<b>FWHID50611</b>	2 AP/PA	29.91 (2.78)	51 3/4" (1314)	55 1/8" (1400)	78 1/8" (1984)	17.38 (1.61)	29.91 (2.78)	33.89 (3.15)
<b>FWHID50611</b>	1 AP/PA	14.09 (1.31)	24 5/16" (618)	26" (660)	78 1/8" (1984)	17.38 (1.61)	14.09 (1.31)	33.89 (3.15)
<b>FWHID54611</b>	1 AS/SA	15.17 (1.41)	26 5/16" (668)	28" (711)	78 1/8" (1984)	19.22 (1.79)	15.17 (1.41)	36.18 (3.36)
<b>FWHID54611</b>	2 AP/PA	32.08 (2.98)	55 3/4" (1416)	59 1/8" (1502)	78 1/8" (1984)	19.22 (1.79)	32.08 (2.98)	36.18 (3.36)
<b>FWHID54611</b>	1 AP/PA	15.17 (1.41)	26 5/16" (668)	28" (711)	78 1/8" (1984)	19.22 (1.79)	15.17 (1.41)	36.18 (3.36)
<b>FWHID60611</b>	1 AS/SA	17.34 (1.61)	30 5/16" (770)	32" (813)	78 1/8" (1984)	22.91 (2.13)	17.34 (1.61)	40.76 (3.79)
<b>FWHID60611</b>	2 AP/PA	36.42 (3.38)	63 3/4" (1619)	67 1/8" (1705)	78 1/8" (1984)	22.91 (2.13)	36.42 (3.38)	40.76 (3.79)
<b>FWHID60611</b>	1 AP/PA	17.34 (1.61)	30 5/16" (770)	32" (813)	78 1/8" (1984)	22.91 (2.13)	17.34 (1.61)	40.76 (3.79)
<b>FWHID64611</b>	1 AS/SA	18.43 (1.71)	32 5/16" (821)	34" (864)	78 1/8" (1984)	24.75 (2.30)	18.43 (1.71)	43.05 (4.00)
<b>FWHID64611</b>	2 AP/PA	38.59 (3.59)	67 3/4" (1720)	71 1/8" (1806)	78 1/8" (1984)	24.75 (2.30)	38.59 (3.59)	43.05 (4.00)
<b>FWHID64611</b>	1 AP/PA	18.43 (1.71)	32 5/16" (821)	34" (864)	78 1/8" (1984)	24.75 (2.30)	18.43 (1.71)	43.05 (4.00)
<b>FWHID2180S**</b>	1	12.65 (1.18)	18 5/16" (465)	20" (508)	91 1/2" (2324)	7.10 (0.66)	12.65 (1.18)	15.98 (1.48)
<b>FWHID2780</b>	1	16.46 (1.53)	24 5/16" (618)	26" (660)	91 1/2" (2324)	10.41 (0.97)	16.46 (1.53)	19.96 (1.85)
<b>FWHID2980</b>	1	17.72 (1.65)	26 5/16" (668)	28" (711)	91 1/2" (2324)	11.52 (1.07)	17.72 (1.65)	21.28 (1.98)
<b>FWHID3180</b>	1	20.26 (1.88)	30 5/16" (770)	32" (813)	91 1/2" (2324)	13.72 (1.27)	20.26 (1.88)	23.94 (2.22)
<b>FWHID3380</b>	1	21.53 (2.00)	32 5/16" (821)	34" (864)	91 1/2" (2324)	14.82 (1.38)	21.53 (2.00)	25.26 (2.35)
<b>FWHID4080</b>	2	27.33 (2.54)	39 3/4" (1009)	43 1/8" (1095)	91 1/2" (2324)	14.20 (1.32)	27.33 (2.54)	31.34 (2.91)
<b>FWHID4080</b>	1	12.65 (1.18)	18 5/16" (465)	20" (508)	91 1/2" (2324)	14.20 (1.32)	12.65 (1.18)	31.34 (2.91)
<b>FWHID5080</b>	1 AS/SA	16.46 (1.53)	24 5/16" (618)	26" (660)	91 1/2" (1984)	20.82 (1.93)	16.46 (1.53)	39.29 (3.65)
<b>FWHID5080</b>	2 AP/PA	34.93 (3.25)	51 3/4" (1314)	55 1/8" (1400)	91 1/2" (2324)	20.82 (1.93)	34.93 (3.24)	39.29 (3.65)
<b>FWHID5080</b>	1 AP/PA	16.45 (1.53)	24 5/16" (618)	26" (660)	91 1/2" (2324)	20.82 (1.93)	16.45 (1.53)	39.29 (3.65)
<b>FWHID5480</b>	1 AS/SA	17.72 (1.65)	26 5/16" (668)	28" (711)	91 1/2" (2324)	23.03 (2.14)	17.72 (1.65)	41.95 (3.90)
<b>FWHID5480</b>	2 AP/PA	37.47 (3.48)	55 3/4" (1416)	59 1/8" (1502)	91 1/2" (2324)	23.03 (2.14)	37.47 (3.48)	41.95 (3.90)
<b>FWHID5480</b>	1 AP/PA	17.72 (1.65)	26 5/16" (668)	28" (711)	91 1/2" (2324)	23.03 (2.14)	17.72 (1.65)	41.95 (3.90)
<b>FWHID6080</b>	1 AS/SA	20.26 (1.88)	30 5/16" (770)	32" (813)	91 1/2" (2324)	27.44 (2.55)	20.26 (1.88)	47.25 (4.39)
<b>FWHID6080</b>	2 AP/PA	42.54 (3.95)	63 3/4" (1619)	67 1/8" (1705)	91 1/2" (2324)	27.44 (2.55)	42.54 (3.95)	47.25 (4.39)
<b>FWHID6080</b>	1 AP/PA	20.26 (1.88)	30 5/16" (770)	32" (813)	91 1/2" (2324)	27.44 (2.55)	20.26 (1.88)	47.25 (4.39)
<b>FWHID6480</b>	1 AS/SA	21.53 (2.00)	32 5/16" (821)	34" (864)	91 1/2" (2324)	29.65 (2.75)	21.53 (2.00)	49.91 (4.64)
<b>FWHID6480</b>	2 AP/PA	45.07 (4.19)	67 3/4" (1720)	71 1/8" (1806)	91 1/2" (2324)	29.65 (2.75)	45.07 (4.19)	49.91 (4.64)
<b>FWHID6480</b>	1 AP/PA	21.52 (2.00)	32 5/16" (821)	34" (864)	91 1/2" (2324)	29.65 (2.75)	21.52 (2.00)	49.91 (4.64)
<b>FWHID21100S**</b>	1	16.04 (1.49)	18 5/16" (465)	20" (508)	115 1/2" (2934)	9.24 (0.86)	16.04 (1.49)	19.99 (1.86)

\* Dimensions in parentheses are in millimeters or square meters.

\*\* For two-panel AP/PA doors with only one panel open, clear opening is based on the active panel open and the passive panel closed.

\*\* Active left- and right-hinged patio doors also available. Contact your Andersen supplier for more information.

*continued on next page*

**Frenchwood® Hinged Inswing Patio Door Opening and Area Specifications** *(continued)*

Door Number	Number of Panels in Open Position*	Clear Opening Area Sq. Ft./ (m <sup>2</sup> )	Clear Opening Maximums			Glass Area Sq. Ft./ (m <sup>2</sup> )	Vent Area Sq. Ft./ (m <sup>2</sup> )	Overall Door Area Sq. Ft./ (m <sup>2</sup> )
			90° Open Position Width Inches/(mm)	Full Open Position Width Inches/(mm)	Height Inches/(mm)			
FWHID27100	1	20.85 (1.94)	24 5/16" (618)	26" (660)	115 1/2" (2934)	13.56 (1.26)	20.85 (1.94)	24.97 (2.32)
FWHID29100	1	22.46 (2.09)	26 5/16" (668)	28" (711)	115 1/2" (2934)	14.99 (1.39)	22.46 (2.09)	26.63 (2.47)
FWHID31100	1	25.67 (2.39)	30 5/16" (770)	32" (813)	115 1/2" (2934)	17.87 (1.66)	25.67 (2.39)	29.95 (2.78)
FWHID33100	1	27.27 (2.53)	32 5/16" (821)	34" (864)	115 1/2" (2934)	19.30 (1.79)	27.27 (2.53)	31.61 (2.94)
FWHID40100	2	34.59 (3.21)	39 3/4" (1009)	43 1/8" (1095)	115 1/2" (2934)	18.50 (1.72)	34.59 (3.21)	39.21 (3.64)
FWHID50100	2 AP/PA	44.21 (4.11)	51 3/4" (1314)	55 1/8" (1400)	115 1/2" (2934)	27.11 (2.52)	44.21 (4.11)	49.17 (4.57)
FWHID50100	1 AP/PA	20.85 (1.94)	24 5/16" (618)	26" (660)	115 1/2" (2934)	27.11 (2.52)	20.85 (1.94)	49.17 (4.57)
FWHID54100	2 AP/PA	47.42 (4.41)	55 3/4" (1416)	59 1/8" (1502)	115 1/2" (2934)	29.99 (2.79)	47.42 (4.41)	52.49 (4.88)
FWHID54100	1 AP/PA	22.46 (2.09)	26 5/16" (668)	28" (711)	115 1/2" (2934)	29.99 (2.79)	22.46 (2.09)	52.49 (4.88)
FWHID60100	2 AP/PA	53.84 (5.00)	63 3/4" (1619)	67 1/8" (1705)	115 1/2" (2934)	35.73 (3.32)	53.84 (5.00)	59.13 (5.49)
FWHID60100	1 AP/PA	25.67 (2.39)	30 5/16" (770)	32" (813)	115 1/2" (2934)	35.73 (3.32)	25.67 (2.39)	59.13 (5.49)
FWHID64100	2 AP/PA	57.05 (5.30)	67 3/4" (1720)	71 1/8" (1806)	115 1/2" (2934)	38.61 (3.59)	57.05 (5.30)	62.45 (5.80)
FWHID64100	1 AP/PA	27.27 (2.53)	32 5/16" (821)	34" (864)	115 1/2" (2934)	38.61 (3.59)	27.27 (2.53)	62.45 (5.80)

\*Dimensions in parentheses are in millimeters or square meters.

\*For two-panel AP/PA doors with only one panel open, clear opening is based on the active panel open and the passive panel closed.

**Frenchwood® Hinged Inswing Patio Door Details – 6 9/16" (167) Jamb Depth**

Scale 1 1/2" (38) = 1'-0" (305) – 1:8

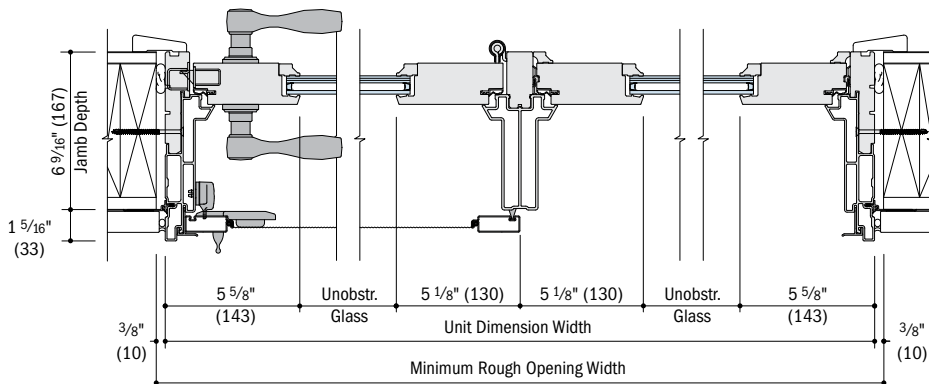
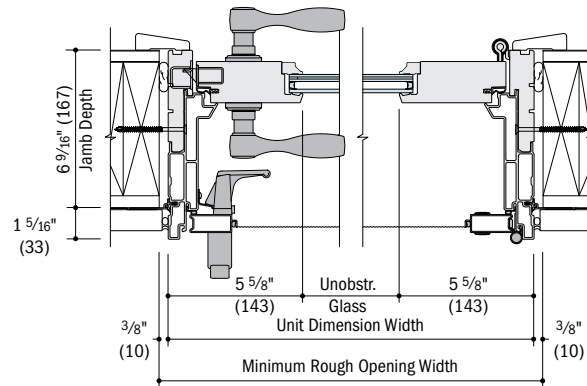
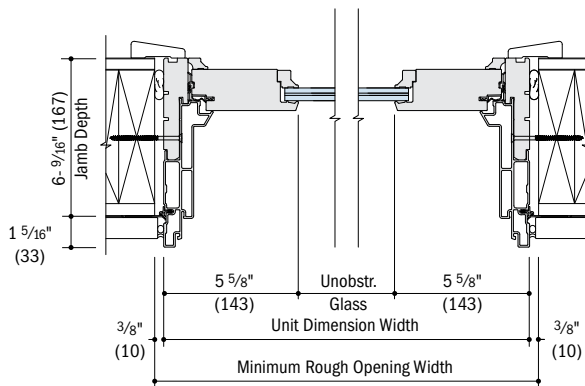

\* 6 9/16" (167) jamb depth measurement is from back side of installation flange.

\* Light-colored areas are parts included with door. Dark-colored areas are additional Andersen® parts required to complete door assembly as shown.

\* Dimensions in parentheses are in millimeters.

\* **Minimum rough opening dimensions may need to be increased to allow for use of building wraps, flashing, sill panning, brackets, fasteners or other items. See installation information on page 170.**

\* Details are for illustration only and are not intended to represent product installation methods or materials. Refer to product installation guides at andersenwindows.com.

\* Insect screens are not available for door heights greater than 95 1/2" (2426).

**Frenchwood® Hinged Inswing Patio Door Details – 6 9/16" (167) Jamb Depth**

Scale 1 1/2" (38) = 1'-0" (305) – 1:8

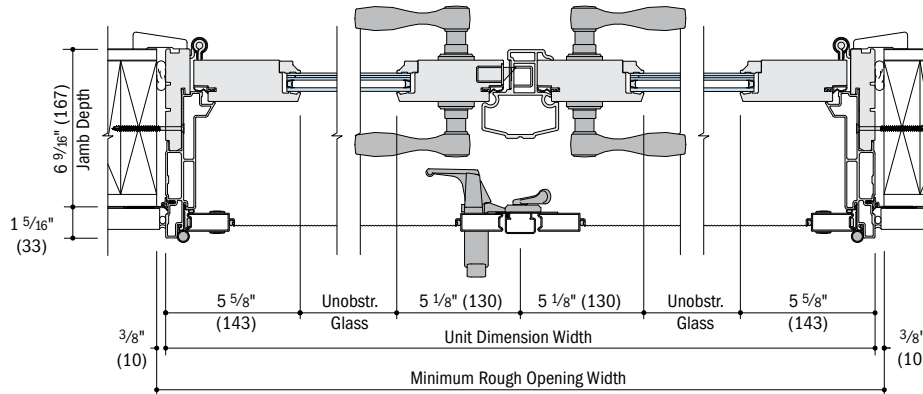

**Horizontal Section – Two-Panel Active-Passive (APLR/PALR)**  
Hinged Insect Screen with Astragal\* – Low-E4\* Impact-Resistant Glass

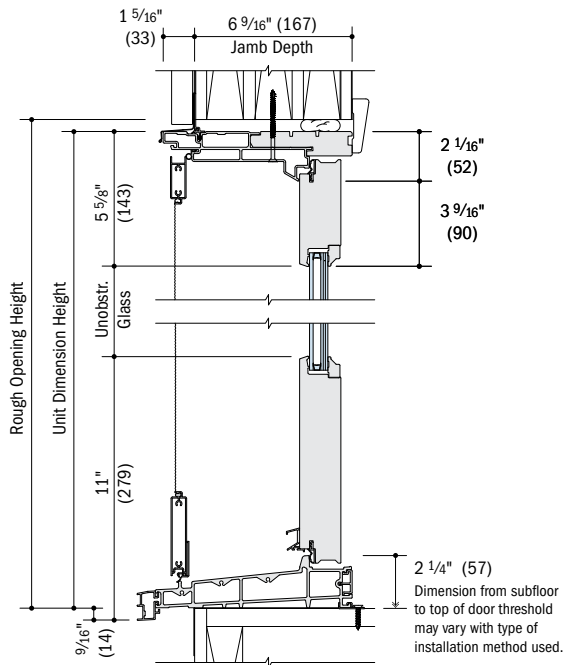

**Vertical Section – Active**  
Hinged Insect Screen\* – Low-E4\* Impact-Resistant Glass

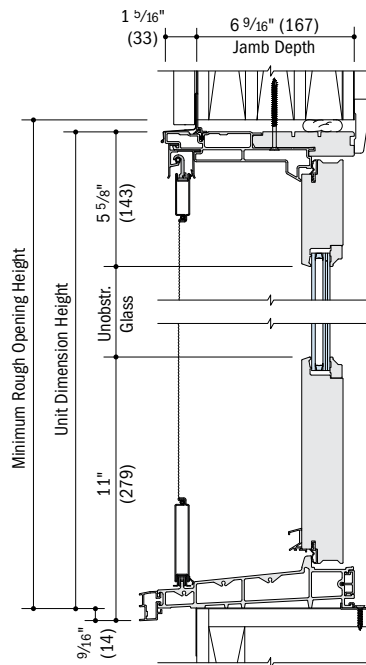

**Vertical Section – Active**  
Top-Hung Gliding Insect Screen\* – Low-E4\* Impact-Resistant Glass

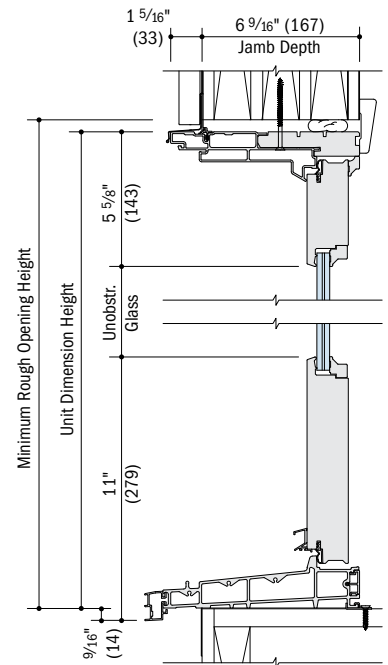

**Vertical Section – Stationary**  
Monolithic SmartSun™ Impact-Resistant Glass

- \* 6 9/16" (167) jamb depth measurement is from back side of installation flange.
- Light-colored areas are parts included with door. Dark-colored areas are additional Andersen® parts required to complete door assembly as shown.
- Dimensions in parentheses are in millimeters.
- **Minimum rough opening dimensions may need to be increased to allow for use of building wraps, flashing, sill panning, brackets, fasteners or other items. See installation information on page 170.**
- Details are for illustration only and are not intended to represent product installation methods or materials. Refer to product installation guides at andersenwindows.com.
- Insect screens are not available for door heights greater than 95 1/2" (2426).



**Frenchwood® Hinged Inswing Patio Door Details – 4 9/16" (116) Jamb Depth**

Scale 1 1/2" (38) = 1'-0" (305) – 1:8

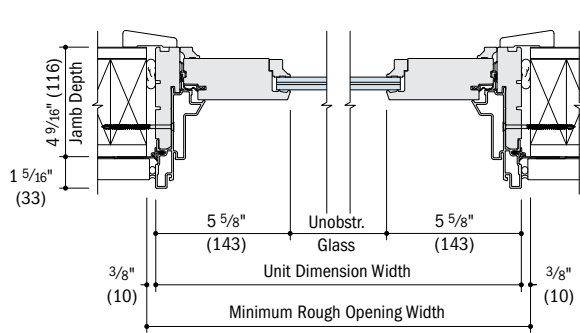

**Horizontal Section – Stationary (S)**  
Monolithic SmartSun™ Impact-Resistant Glass

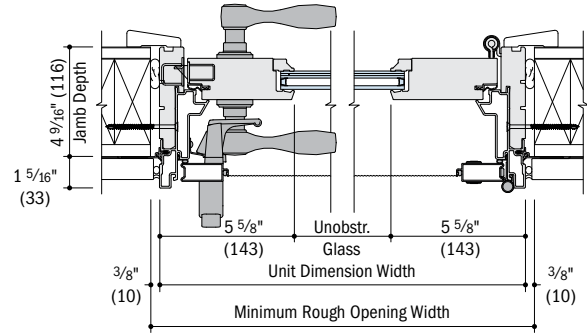

**Horizontal Section – Active (AR/AL)**  
Hinged Insect Screen\* – Low-E4® Impact-Resistant Glass

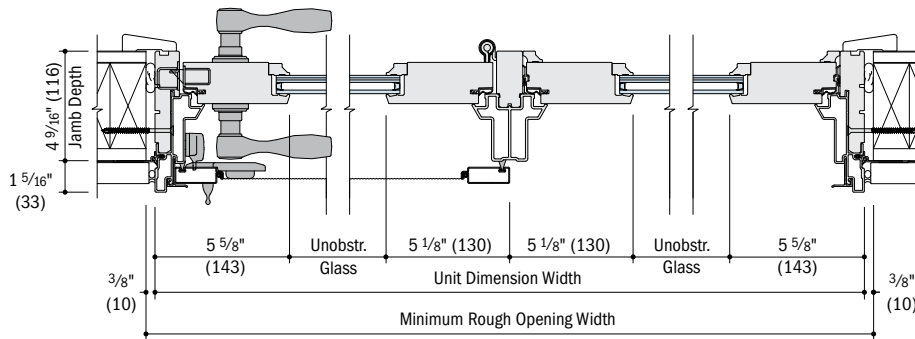

**Horizontal Section – Two-Panel Active-Stationary (ASR/ASL/SAL/SAR)**  
Top-Hung Gliding or Gliding Insect Screen\* – Low-E4® Impact-Resistant Glass

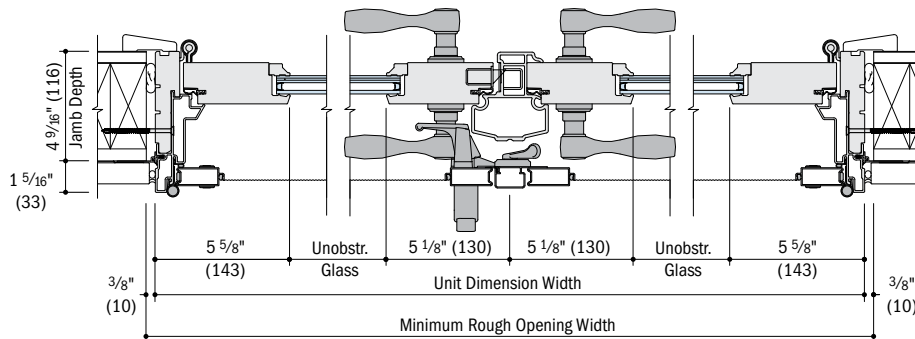

**Horizontal Section – Two-Panel Active-Passive (APL/PALR)**  
Hinged Insect Screen\* – Low-E4® Impact-Resistant Glass

- 4 9/16" (116) jamb depth measurement is from back side of installation flange.
- Light-colored areas are parts included with door. Dark-colored areas are additional Andersen® parts required to complete door assembly as shown.
- Dimensions in parentheses are in millimeters.
- **Minimum rough opening dimensions may need to be increased to allow for use of building wraps, flashing, sill panning, brackets, fasteners or other items. See installation information on page 170.**
- Details are for illustration only and are not intended to represent product installation methods or materials. Refer to product installation guides at andersenwindows.com.
- \*Insect screens are not available for door heights greater than 95 1/2" (2426).

**Frenchwood® Hinged Inswing Patio Door Details – 4 9/16" (116) Jamb Depth**

Scale 1 1/2" (38) = 1'-0" (305) – 1:8

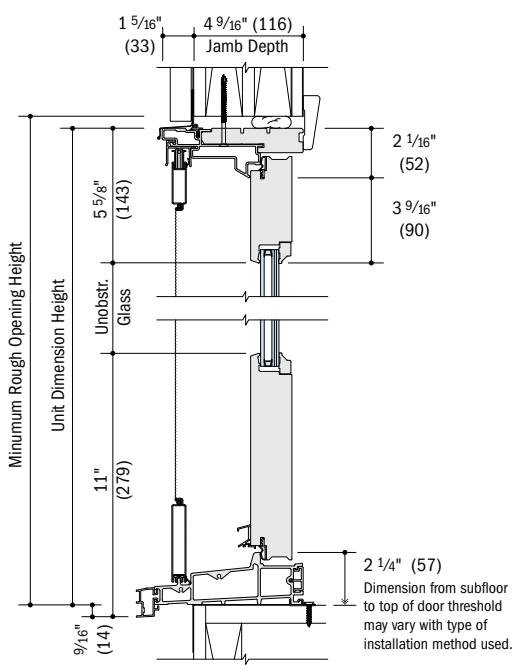

**Vertical Section – Active**  
Gliding Insect Screen\* – Low-E4® Impact-Resistant Glass

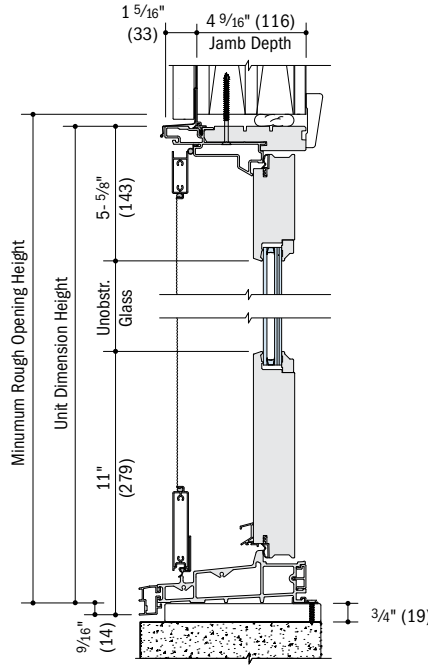

**Vertical Section – Active**  
Hinged Insect Screen\* – Low-E4® Impact-Resistant Glass

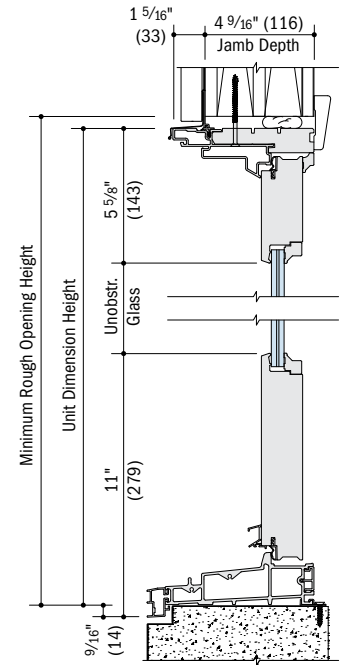

**Vertical Section – Stationary**  
Monolithic SmartSun™ Impact-Resistant Glass

**Remodeler Sill Bracket**

Optional remodeler sill bracket is available for installations with an existing finished interior floor.

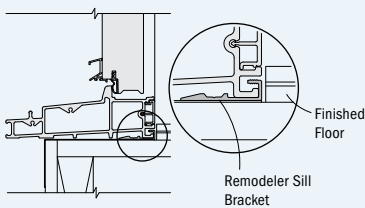

**Drop-Nose Channel**

Optional drop-nose channel is available when higher product performance is required. Wood and concrete installations shown.

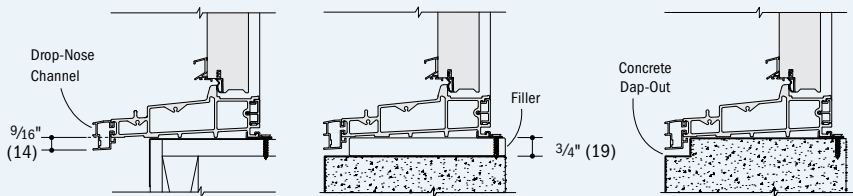

See pages 134-137 for horizontal and vertical joining details.

- 4 9/16" (116) jamb depth measurement is from back side of installation flange.
- Light-colored areas are parts included with door. Dark-colored areas are additional Andersen® parts required to complete door assembly as shown.
- Dimensions in parentheses are in millimeters.
- **Minimum rough opening dimensions may need to be increased to allow for use of building wraps, flashing, sill panning, brackets, fasteners or other items. See installation information on page 170.**
- Details are for illustration only and are not intended to represent product installation methods or materials. Refer to product installation guides at andersenwindows.com.
- Insect screens are not available for door heights greater than 95 1/2" (2426).

**Four Patio Door Heights**

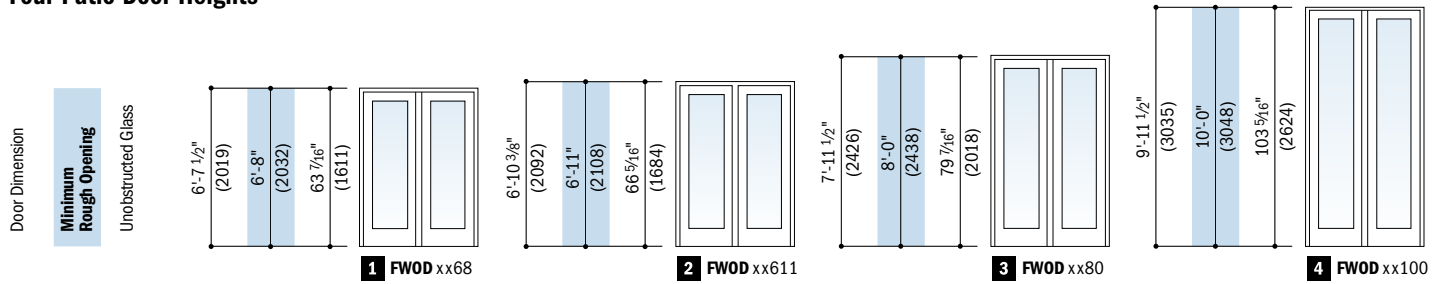

**Table of Frenchwood® Hinged Outswing Patio Door Sizes**

Scale 1/8" (3) = 1'-0" (305) – 1:96

Door Dimension	2'-0 1/8"	3'-11 1/4"	2'-6 1/8"	2'-6 1/8"	2'-6 1/8"	4'-11 1/4"
Minimum Rough Opening	2'-1"	4'-0"	2'-7"	2'-7"	2'-7"	5'-0"
Unobstructed Glass (single panel only)	12 7/8"	12 7/8"	18 7/8"	18 7/8"	18 7/8"	18 7/8"
4 heights						
1 FWOD	2168S*	4068APLR/4068PALR	2768S	2768AR	2768AL	5068APLR/5068PALR
2 FWOD	21611S*	40611APLR/40611PALR	27611S	27611AR	27611AL	50611APLR/50611PALR
3 FWOD	2180S*	4080APLR/4080PALR	2780S	2780AR	2780AL	5080APLR/5080PALR
4 FWOD	21100S*	40100APLR/40100PALR	27100S	27100AR	27100AL	50100APLR/50100PALR

Door Dimension	2'-8 1/8"	2'-8 1/8"	2'-8 1/8"	5'-3 1/4"	3'-0 1/8"	3'-0 1/8"	3'-0 1/8"	5'-11 1/4"
Minimum Rough Opening	2'-9"	2'-9"	2'-9"	5'-4"	3'-1"	3'-1"	3'-1"	6'-0"
Unobstructed Glass (single panel only)	20 7/8"	20 7/8"	20 7/8"	20 7/8"	24 7/8"	24 7/8"	24 7/8"	24 7/8"
4 heights								
1 FWOD	2968S	2968AR	2968AL	5468APLR/5468PALR	3168S	3168AR	3168AL	6068APLR/6068PALR
2 FWOD	29611S	29611AR	29611AL	54611APLR/54611PALR	31611S	31611AR	31611AL	60611APLR/60611PALR
3 FWOD	2980S	2980AR	2980AL	5480APLR/5480PALR	3180S	3180AR	3180AL	6080APLR/6080PALR
4 FWOD	29100S	29100AR	29100AL	54100APLR/54100PALR	31100S	31100AR	31100AL	60100APLR/60100PALR

Door Dimension	3'-2 1/8"	3'-2 1/8"	3'-2 1/8"	6'-3 1/4"
Minimum Rough Opening	3'-3"	3'-3"	3'-3"	6'-4"
Unobstructed Glass (single panel only)	26 7/8"	26 7/8"	26 7/8"	26 7/8"
4 heights				
1 FWOD	3368S	3368AR	3368AL	6468APLR/6468PALR
2 FWOD	33611S	33611AR	33611AL	64611APLR/64611PALR
3 FWOD	3380S	3380AR	3380AL	6480APLR/6480PALR
4 FWOD	33100S	33100AR	33100AL	64100APLR/64100PALR



**Custom-size patio doors are available in 1/8" (3) increments.** See pages 139 for custom sizes, specifications and information on shipping patio doors greater than 95 1/2" (2426).

Stationary (S) patio doors can be used as an individual patio door or as a sidelight. Two-panel doors greater than 95 1/2" (2426) in height are available unassembled only.

Details shown on pages 124-125. Grille patterns shown on page 123.

A-Series Frenchwood® Hinged Outswing Patio Doors

\*"Door Dimension" always refers to outside frame to frame dimension.  
 \*\*"Minimum Rough Opening" dimensions may need to be increased to allow for use of building wraps, flashing, sill panning, brackets, fasteners or other items. See installation information on page 170.  
 • Dimensions in parentheses are in millimeters.  
 \*Active left- and right-hinged patio doors also available. Contact your Andersen supplier for more information.

Identification

Viewed from the exterior.

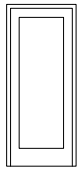

**Stationary**  
(non-operating panel)

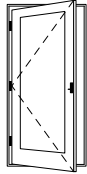

**Left Hinged**  
(hinges on left)

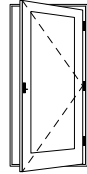

**Right Hinged**  
(hinges on right)

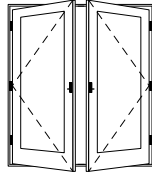

**Active Panel**  
(operating panel used most often)

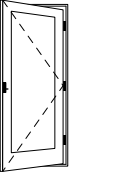

**Passive Panel**  
(operating panel with attached astragal)

Order Designation Description

Viewed from the exterior.

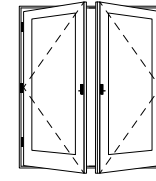

**FWOD** Frenchwood® Hinged Outswing Patio Door  
**6068** Door Rough Opening  
**A** Active Panel (panel used most often)  
**P** Passive Panel  
**L** Left Hinged  
**R** Right Hinged

Frenchwood® Hinged Outswing Patio Door Opening and Area Specifications

Door Number	Number of Panels in Open Position*	Clear Opening Maximums			Glass Area Sq. Ft./ (m <sup>2</sup> )	Vent Sq. Ft./ (m <sup>2</sup> )	Overall Door Area Sq. Ft./ (m <sup>2</sup> )
		Clear Opening Sq. Ft./ (m <sup>2</sup> )	90° Open Position Width Inches/ (mm)	Full Open Position Width Inches/ (mm)			
FWOD2168S**	1	10.94 (1.02)	19 1/16" (484)	20 3/8" (527)	76 1/8" (1934)	5.67 (0.53)	10.94 (1.02) 13.30 (1.24)
FWOD2768	1	14.11 (1.31)	25 1/16" (637)	26 3/4" (679)	76 1/8" (1934)	8.31 (0.77)	14.11 (1.31) 16.61 (1.54)
FWOD2968	1	15.17 (1.41)	27 1/16" (687)	28 3/4" (730)	76 1/8" (1934)	9.20 (0.85)	15.17 (1.41) 17.72 (1.65)
FWOD3168	1	17.28 (1.61)	31 1/16" (789)	32 3/4" (832)	76 1/8" (1934)	10.96 (1.02)	17.28 (1.61) 19.93 (1.85)
FWOD3368	1	18.34 (1.70)	33 1/16" (840)	34 3/8" (883)	76 1/8" (1934)	11.84 (1.10)	18.34 (1.70) 21.03 (1.95)
FWOD4068	2	23.18 (2.15)	40 5/8" (1032)	43 7/8" (1114)	76 1/8" (1934)	11.34 (1.05)	23.18 (2.15) 26.09 (2.42)
FWOD4068	1	10.89 (1.01)	19" (483)	20 5/8" (524)	76 1/8" (1934)	11.34 (1.05)	10.89 (1.01) 26.09 (2.42)
FWOD5068	2	29.52 (2.74)	52 5/8" (1337)	55 7/8" (1419)	76 1/8" (1934)	16.63 (1.54)	29.52 (2.74) 32.71 (3.04)
FWOD5068	1	14.07 (1.31)	25" (635)	26 5/8" (676)	76 1/8" (1934)	16.63 (1.54)	14.07 (1.31) 32.71 (3.04)
FWOD5468	2	31.63 (2.94)	56 5/8" (1438)	59 7/8" (1521)	76 1/8" (1934)	18.39 (1.71)	31.63 (2.94) 34.92 (3.24)
FWOD5468	1	15.12 (1.40)	27" (686)	28 5/8" (727)	76 1/8" (1934)	18.39 (1.71)	15.12 (1.40) 34.92 (3.24)
FWOD6068	2	35.86 (3.33)	64 5/8" (1641)	67 7/8" (1724)	76 1/8" (1934)	21.92 (2.04)	35.86 (3.33) 39.34 (3.65)
FWOD6068	1	17.24 (1.60)	31" (787)	32 5/8" (829)	76 1/8" (1934)	21.92 (2.04)	17.24 (1.60) 39.34 (3.65)
FWOD6468	2	37.97 (3.53)	68 5/8" (1743)	71 7/8" (1826)	76 1/8" (1934)	23.68 (2.20)	37.97 (3.53) 41.54 (3.86)
FWOD6468	1	18.29 (1.70)	33" (838)	34 5/8" (879)	76 1/8" (1934)	23.68 (2.20)	18.29 (1.70) 41.54 (3.86)
FWOD21611S**	1	11.35 (1.05)	19 1/16" (484)	20 3/4" (527)	79" (2007)	5.93 (0.55)	11.35 (1.05) 13.78 (1.28)
FWOD27611	1	14.64 (1.36)	25 1/16" (637)	26 3/4" (679)	79" (2007)	8.69 (0.81)	14.64 (1.36) 17.22 (1.60)
FWOD29611	1	15.74 (1.46)	27 1/16" (687)	28 3/4" (730)	79" (2007)	9.61 (0.89)	15.74 (1.46) 18.36 (1.71)
FWOD31611	1	17.93 (1.67)	31 1/16" (789)	32 3/4" (832)	79" (2007)	11.45 (1.06)	17.93 (1.67) 20.65 (1.92)
FWOD33611	1	19.03 (1.77)	33 1/16" (840)	34 3/4" (883)	79" (2007)	12.38 (1.15)	19.03 (1.77) 21.79 (2.02)
FWOD40611	2	24.05 (2.23)	40 5/8" (1032)	43 7/8" (1114)	79" (2007)	11.86 (1.10)	24.05 (2.23) 27.03 (2.51)
FWOD40611	1	11.31 (1.05)	19" (483)	20 5/8" (524)	79" (2007)	11.86 (1.10)	11.31 (1.05) 27.03 (2.51)
FWOD50611	2	30.63 (2.85)	52 5/8" (1337)	55 7/8" (1419)	79" (2007)	17.38 (1.61)	30.63 (2.85) 33.89 (3.15)
FWOD50611	1	14.60 (1.36)	25" (635)	26 5/8" (676)	79" (2007)	17.38 (1.61)	14.60 (1.36) 33.89 (3.15)
FWOD54611	2	32.83 (3.05)	56 5/8" (1438)	59 7/8" (1521)	79" (2007)	19.22 (1.79)	32.83 (3.05) 36.18 (3.36)
FWOD54611	1	15.69 (1.46)	27" (686)	28 5/8" (727)	79" (2007)	19.22 (1.79)	15.69 (1.46) 36.18 (3.36)
FWOD60611	2	37.21 (3.46)	64 5/8" (1641)	67 7/8" (1724)	79" (2007)	22.91 (2.13)	37.21 (3.46) 40.76 (3.79)
FWOD60611	1	17.89 (1.66)	31" (787)	32 5/8" (829)	79" (2007)	22.91 (2.13)	17.89 (1.66) 40.76 (3.79)
FWOD64611	2	39.41 (3.66)	68 5/8" (1743)	71 7/8" (1826)	79" (2007)	24.75 (2.30)	39.41 (3.66) 43.05 (4.00)
FWOD64611	1	18.98 (1.76)	33" (838)	34 5/8" (879)	79" (2007)	24.75 (2.30)	18.98 (1.76) 43.05 (4.00)
FWOD2180S**	1	13.24 (1.23)	19 1/16" (484)	20 3/4" (527)	92 1/8" (2340)	7.10 (0.66)	13.24 (1.23) 15.98 (1.48)
FWOD2780	1	17.07 (1.59)	25 1/16" (637)	26 3/4" (679)	92 1/8" (2340)	10.41 (0.97)	17.07 (1.59) 19.96 (1.85)
FWOD2980	1	18.35 (1.71)	27 1/16" (687)	28 3/4" (730)	92 1/8" (2340)	11.52 (1.07)	18.35 (1.71) 21.28 (1.98)
FWOD3180	1	20.91 (1.94)	31 1/16" (789)	32 3/4" (832)	92 1/8" (2340)	13.72 (1.27)	20.91 (1.94) 23.94 (2.22)
FWOD3380	1	22.19 (2.06)	33 1/16" (840)	34 3/4" (883)	92 1/8" (2340)	14.82 (1.38)	22.19 (2.06) 25.26 (2.35)
FWOD4080	2	28.05 (2.61)	40 5/8" (1032)	43 7/8" (1114)	92 1/8" (2340)	14.20 (1.32)	28.05 (2.61) 31.34 (2.91)
FWOD4080	1	13.18 (1.22)	19" (483)	20 3/8" (524)	92 1/8" (2340)	14.20 (1.32)	13.18 (1.22) 31.34 (2.91)
FWOD5080	2	35.72 (3.32)	52 5/8" (1337)	55 7/8" (1419)	92 1/8" (2340)	20.82 (1.93)	35.72 (3.32) 39.29 (3.65)
FWOD5080	1	17.02 (1.58)	25" (635)	26 5/8" (676)	92 1/8" (2340)	20.82 (1.93)	17.02 (1.58) 39.29 (3.65)
FWOD5480	2	38.28 (3.56)	56 5/8" (1438)	59 7/8" (1521)	92 1/8" (2340)	23.03 (2.14)	38.28 (3.56) 41.95 (3.90)
FWOD5480	1	18.30 (1.70)	27" (686)	28 5/8" (727)	92 1/8" (2340)	23.03 (2.14)	18.30 (1.70) 41.95 (3.90)
FWOD6080	2	43.40 (4.03)	64 5/8" (1641)	67 7/8" (1724)	92 1/8" (2340)	27.44 (2.55)	43.40 (4.03) 47.25 (4.39)
FWOD6080	1	20.86 (1.94)	31" (787)	32 5/8" (829)	92 1/8" (2340)	27.44 (2.55)	20.86 (1.94) 47.25 (4.39)
FWOD6480	2	45.96 (4.27)	68 5/8" (1743)	71 7/8" (1826)	92 1/8" (2340)	29.65 (2.75)	45.96 (4.27) 49.91 (4.64)
FWOD6480	1	22.14 (2.06)	33" (838)	34 5/8" (879)	92 1/8" (2340)	29.65 (2.75)	22.14 (2.06) 49.91 (4.64)

\* Dimensions in parentheses are in millimeters or square meters.  
 \*\*For two-panel doors with only one panel open, clear opening is based on the active panel open and the passive panel closed.  
 \*\*\*Active left- and right-hinged patio doors also available. Contact your Andersen supplier for more information.

continued on next page

**Frenchwood® Hinged Outswing Patio Door Opening and Area Specifications** *(continued)*

Door Number	Number of Panels in Open Position*	Clear Opening Sq. Ft./ (m <sup>2</sup> )	Clear Opening Maximums			Glass Area Sq. Ft./ (m <sup>2</sup> )	Vent Sq. Ft./ (m <sup>2</sup> )	Overall Door Area Sq. Ft./ (m <sup>2</sup> )
			90° Open Position Width Inches/(mm)	Full Open Position Width Inches/(mm)	Height Inches/(mm)			
FWOD21100S**	1	16.73 (1.55)	19 1/16" (484)	20 3/4" (527)	116 1/8" (2950)	8.77 (0.81)	16.73 (1.55)	19.99 (1.86)
FWOD27100	1	21.57 (2.00)	25 1/16" (637)	26 3/4" (679)	116 1/8" (2950)	13.08 (1.21)	21.57 (2.00)	24.97 (2.32)
FWOD29100	1	23.18 (2.15)	27 1/16" (687)	28 3/4" (730)	116 1/8" (2950)	14.51 (1.35)	23.18 (2.15)	26.63 (2.47)
FWOD31100	1	26.41 (2.45)	31 1/16" (789)	32 3/4" (832)	116 1/8" (2950)	17.38 (1.61)	26.41 (2.45)	29.95 (2.78)
FWOD33100	1	28.02 (2.60)	33 1/16" (840)	34 3/4" (883)	116 1/8" (2950)	18.82 (1.75)	28.02 (2.60)	31.61 (2.94)
FWOD40100	2	35.38 (3.29)	40 5/8" (1032)	43 7/8" (1114)	116 1/8" (2950)	17.54 (1.63)	35.38 (3.29)	39.21 (3.64)
FWOD40100	1	16.63 (1.55)	19" (483)	20 5/8" (524)	116 1/8" (2950)	17.54 (1.63)	16.63 (1.55)	39.21 (3.64)
FWOD50100	2	45.06 (4.19)	52 5/8" (1337)	55 7/8" (1419)	116 1/8" (2950)	26.16 (2.43)	45.06 (4.19)	49.17 (4.57)
FWOD50100	1	21.47 (1.99)	25" (635)	26 5/8" (676)	116 1/8" (2950)	26.16 (2.43)	21.47 (1.99)	49.17 (4.57)
FWOD54100	2	48.28 (4.49)	56 5/8" (1438)	59 7/8" (1521)	116 1/8" (2950)	29.03 (2.70)	48.28 (4.49)	52.49 (4.88)
FWOD54100	1	23.08 (2.14)	27" (686)	28 5/8" (727)	116 1/8" (2950)	29.03 (2.70)	23.08 (2.14)	52.49 (4.88)
FWOD60100	2	54.74 (5.09)	64 5/8" (1641)	67 7/8" (1724)	116 1/8" (2950)	34.77 (3.23)	54.74 (5.09)	59.13 (5.49)
FWOD60100	1	26.31 (2.45)	31" (787)	32 5/8" (829)	116 1/8" (2950)	34.77 (3.23)	26.31 (2.45)	59.13 (5.49)
FWOD64100	2	57.96 (5.39)	68 5/8" (1743)	71 7/8" (1826)	116 1/8" (2950)	37.64 (3.50)	57.96 (5.39)	62.45 (5.80)
FWOD64100	1	27.92 (2.59)	33" (838)	34 5/8" (879)	116 1/8" (2950)	37.64 (3.50)	27.92 (2.59)	62.45 (5.80)

\*Dimensions in parentheses are in millimeters or square meters.  
 \*For two-panel doors with only one panel open, clear opening is based on the active panel open and the passive panel closed.  
 \*\*Active left- and right-hinged patio doors also available. Contact your Andersen supplier for more information.

**Grille Patterns**

	Queen Anne	Diamond	Prairie A	Colonial	Modified Colonial	Modified Colonial with Simulated Meeting Rail	Tall Fractional	Tall Fractional with Simulated Meeting Rail	Short Fractional	Short Fractional with Simulated Meeting Rail
<b>Frenchwood® Gliding, Hinged Inswing &amp; Outswing</b>										

A-Series Frenchwood® Hinged Outswing Patio Doors

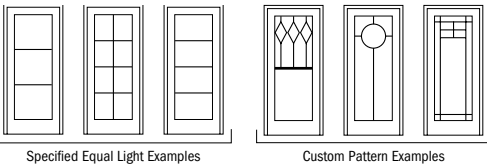

**Number of lights and overall pattern varies with door size. Patterns shown may not be available for all sizes.** Specified equal light and custom patterns are also available. For more information on divided light, see page 15 or visit [andersenwindows.com/grilles](http://andersenwindows.com/grilles).

\*Dimensions in parentheses are in millimeters.  
 \*Details are for illustration only and are not intended to represent product installation methods or materials. Refer to product installation guides at [andersenwindows.com](http://andersenwindows.com).

**Frenchwood® Hinged Outswing Patio Door Details**

Scale 1 1/2" (38) = 1'-0" (305) – 1:8

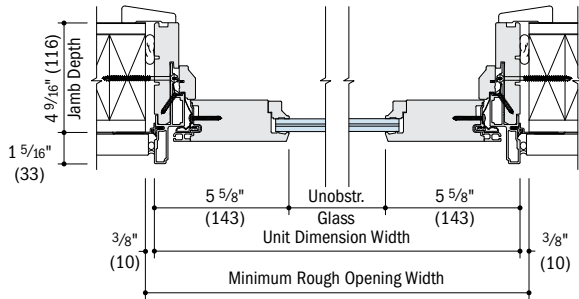

**Horizontal Section – Stationary (S)**  
Monolithic SmartSun™ Impact-Resistant Glass

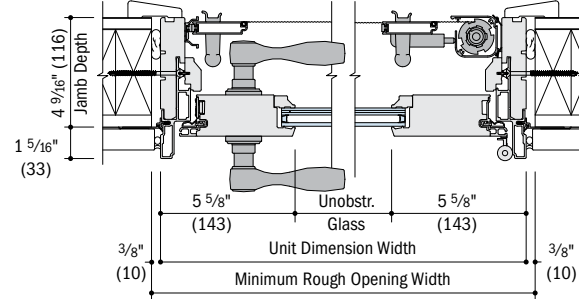

**Horizontal Section – Active (AR/AL)**  
Retractable Insect Screen\* – Low-E4™ Impact-Resistant Glass

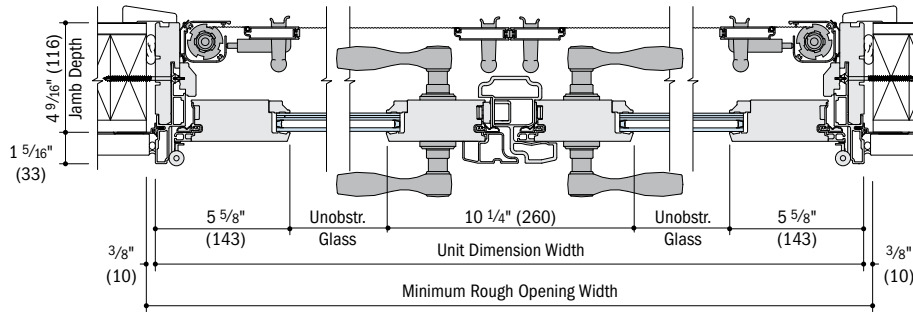

**Horizontal Section – Two-Panel Active-Passive (APLR/PALR)**  
Retractable Insect Screen\* – Low-E4™ Impact-Resistant Glass

- 4 9/16" (116) jamb depth measurement is from back side of installation flange.
- Light-colored areas are parts included with door. Dark-colored areas are additional Andersen® parts required to complete door assembly as shown.
- Dimensions in parentheses are in millimeters.
- **Minimum rough opening dimensions may need to be increased to allow for use of building wraps, flashing, sill panning, brackets, fasteners or other items. See installation information on page 170.**
- Details are for illustration only and are not intended to represent product installation methods or materials. Refer to product installation guides at [andersenwindows.com](http://andersenwindows.com).
- Insect screens are not available for door heights greater than 95 1/2" (2426).

**Frenchwood® Hinged Outswing Patio Door Details**

Scale 1 1/2" (38) = 1'-0" (305) – 1:8

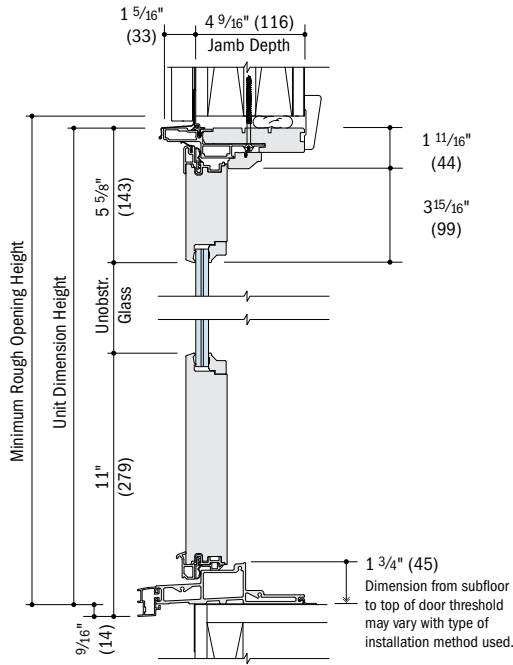

**Vertical Section – Stationary**  
Monolithic SmartSun™ Impact-Resistant Glass

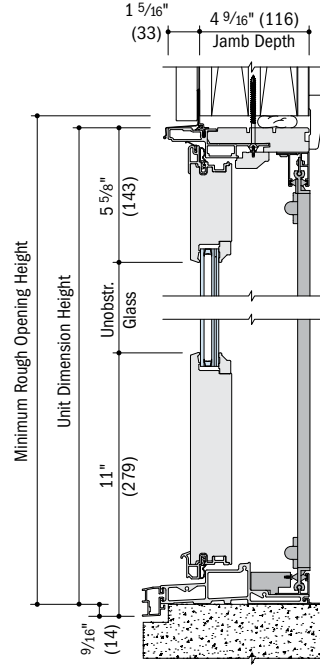

**Vertical Section – Active**  
Retractable Insect Screen\* – Low-E4® Impact-Resistant Glass

**Sill Step**

Optional sill step is available in oak or maple.

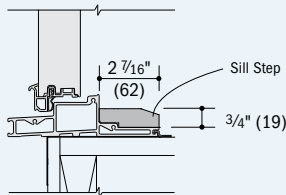

**Drop-Nose Channel**

Optional drop-nose channel is available when higher product performance is required. Wood and concrete installations shown.

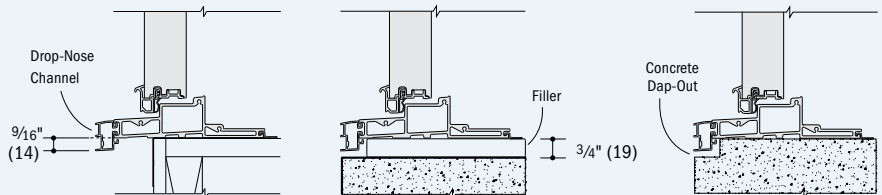

See pages 134-137 for horizontal and vertical joining details.

- 4 9/16" (116) jamb depth measurement is from back side of installation flange.
- Light-colored areas are parts included with door. Dark-colored areas are additional Andersen® parts required to complete door assembly as shown.
- Dimensions in parentheses are in millimeters.
- **Minimum rough opening dimensions may need to be increased to allow for use of building wraps, flashing, sill panning, brackets, fasteners or other items. See installation information on page 170.**
- Details are for illustration only and are not intended to represent product installation methods or materials. Refer to product installation guides at andersenwindows.com.
- \*Insect screens are not available for door heights greater than 95 1/2" (2426).

**Table of Frenchwood® Patio Door Sidelight Transoms, Transoms & Venting Transom Window Sizes**

Notes on the next page also apply to this page.

Scale 1/8" (3) = 1'-0" (305) – 1:96

Transom Dimension	1'-2 1/4" (362)	1'-6 1/4" (464)	2'-0 1/8" (612)	2'-6 1/8" (765)	2'-8 1/8" (816)	3'-0 1/8" (918)	3'-2 1/8" (968)	3'-11 1/4" (1200)	4'-11 1/4" (1505)	5'-3 1/4" (1607)
Minimum Rough Opening	1'-3" (381)	1'-7" (483)	2'-1" (635)	2'-7" (787)	2'-9" (838)	3'-1" (940)	3'-3" (991)	4'-0" (1219)	5'-0" (1524)	5'-4" (1626)

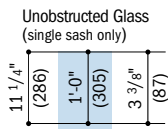

**CUSTOM SIZES AVAILABLE**

11 1/4" (286)	6 3/8" (163)	10 3/8" (264)	12 7/8" (327)	18 7/8" (479)	20 7/8" (530)	24 7/8" (632)	26 7/8" (683)	36" (915)	48" (1220)	52" (1322)
11 1/4" (286)								12 7/8" (327)	18 7/8" (479)	20 7/8" (530)
11 1/4" (286)	10 5/8" (269)	14 5/8" (371)	20 7/16" (519)	26 7/16" (672)	28 7/16" (722)	32 7/16" (824)	34 7/16" (875)	43 5/8" (1107)	55 5/8" (1412)	59 5/8" (1514)
1'-3 1/4" (387)	6 3/8" (163)	10 3/8" (264)	12 7/8" (327)	18 7/8" (479)	20 7/8" (530)	24 7/8" (632)	26 7/8" (683)	36" (915)	48" (1220)	52" (1322)
1'-3 1/4" (387)								12 7/8" (327)	18 7/8" (479)	20 7/8" (530)
1'-3 1/4" (387)	10 5/8" (269)	14 5/8" (371)	20 7/16" (519)	26 7/16" (672)	28 7/16" (722)	32 7/16" (824)	34 7/16" (875)	40 5/8" (1032)	52 5/8" (1337)	56 5/8" (1438)
1'-3 1/4" (387)			17 5/8" (448)	23 5/8" (600)	25 5/8" (651)	29 5/8" (752)	31 5/8" (803)	40 5/8" (1032)	52 5/8" (1337)	56 5/8" (1438)
1'-3 1/4" (387)	10 5/8" (269)	14 5/8" (371)	20 7/16" (519)	26 7/16" (672)	28 7/16" (722)	32 7/16" (824)	34 7/16" (875)	43 5/8" (1107)	55 5/8" (1412)	59 5/8" (1514)
1'-7 1/4" (489)	6 3/8" (163)	10 3/8" (264)	12 7/8" (327)	18 7/8" (479)	20 7/8" (530)	24 7/8" (632)	26 7/8" (683)	36" (915)	48" (1220)	52" (1322)
1'-7 1/4" (489)								12 7/8" (327)	18 7/8" (479)	20 7/8" (530)
1'-7 1/4" (489)	10 5/8" (269)	14 5/8" (371)	20 7/16" (519)	26 7/16" (672)	28 7/16" (722)	32 7/16" (824)	34 7/16" (875)	40 5/8" (1032)	52 5/8" (1337)	56 5/8" (1438)
1'-7 1/4" (489)			17 5/8" (448)	23 5/8" (600)	25 5/8" (651)	29 5/8" (752)	31 5/8" (803)	40 5/8" (1032)	52 5/8" (1337)	56 5/8" (1438)
1'-7 1/4" (489)	10 5/8" (269)	14 5/8" (371)	20 7/16" (519)	26 7/16" (672)	28 7/16" (722)	32 7/16" (824)	34 7/16" (875)	43 5/8" (1107)	55 5/8" (1412)	59 5/8" (1514)
1'-11 1/4" (591)	6 3/8" (163)	10 3/8" (264)	12 7/8" (327)	18 7/8" (479)	20 7/8" (530)	24 7/8" (632)	26 7/8" (683)	36" (915)	48" (1220)	52" (1322)
1'-11 1/4" (591)								12 7/8" (327)	18 7/8" (479)	20 7/8" (530)



Patio door sidelight and transom sizes on pages 126-130.

5'-11 1/4" (1810)	6'-3 1/4" (1911)	6'-11 1/4" (2114)	7'-10 7/16" (2398)	7'-11 1/4" (2419)
6'-0" (1829)	6'-4" (1930)	7'-0" (2133)	7'-11" (2413)	8'-0" (2438)

60" (1525)	64" (1626)	72" (1830)	83 3/16" (2113)	84" (2134)
<b>FWTD-1-6010</b>	<b>FWTD-1-6410</b>	<b>FWTD-1-7010</b>	<b>FWTD-1-71110</b>	<b>FWTD-1-8010</b>
24 7/8" (632)	26 7/8" (683)			

67 5/8" (1717)	71 5/8" (1818)	79 5/8" (2022)	90 3/4" (2305)	91 5/8" (2326)
<b>FWTDS6010</b>	<b>FWTDS6410</b>	<b>FWTDS7010</b>	<b>FWTDS71110</b>	<b>FWTDS8010</b>

60" (1525)	64" (1626)	72" (1830)	83 3/16" (2113)	84" (2134)
<b>FWTD-1-6014</b>	<b>FWTD-1-6414</b>	<b>FWTD-1-7014</b>	<b>FWTD-1-71114</b>	<b>FWTD-1-8014</b>
24 7/8" (632)	26 7/8" (683)			

64 5/8" (1641)				
<b>FWTD-2-6014</b>	<b>FWTD-2-6414</b>			
<b>ATV6014</b>				

67 5/8" (1717)	71 5/8" (1818)	79 5/8" (2022)	90 3/4" (2305)	91 5/8" (2326)
<b>FWTDS6014</b>	<b>FWTDS6414</b>	<b>FWTDS7014</b>	<b>FWTDS71114</b>	<b>FWTDS8014</b>

60" (1525)	64" (1626)	72" (1830)	83 3/16" (2113)	84" (2134)
<b>FWTD-1-6018</b>	<b>FWTD-1-6418</b>	<b>FWTD-1-7018</b>	<b>FWTD-1-71118</b>	<b>FWTD-1-8018</b>
24 7/8" (632)	26 7/8" (683)			

64 5/8" (1641)				
<b>FWTD-2-6018</b>	<b>FWTD-2-6418</b>			
<b>ATV6018</b>				

67 5/8" (1717)	71 5/8" (1818)	79 5/8" (2022)	90 3/4" (2305)	91 5/8" (2326)
<b>FWTDS6018</b>	<b>FWTDS6418</b>	<b>FWTDS7018</b>	<b>FWTDS71118</b>	<b>FWTDS8018</b>

60" (1525)	64" (1626)	72" (1830)	83 3/16" (2113)	84" (2134)
<b>FWTD-1-6020</b>	<b>FWTD-1-6420</b>	<b>FWTD-1-7020</b>	<b>FWTD-1-71120</b>	<b>FWTD-1-8020</b>
24 7/8" (632)	26 7/8" (683)			

<b>FWTD-2-6020</b>	<b>FWTD-2-6420</b>			



Custom-size patio door sidelight transoms and transom windows are available in 1/8" (3) increments. See page 140 for custom sizes and specifications.

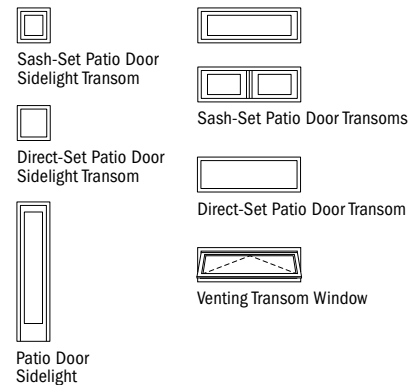

Choose patio door sash-set sidelight transom (**FWSLTD**), direct-set sidelight transom (**FWTDS**), sash-set transom (**FWTD-1**, **FWTD-2**), direct-set transom (**FWTDS**), venting transom window (**ATV**) or patio door sidelights (shown on page 132).

Direct-set transom (**FWTDS**) provides maximum unobstructed glass. **Venting transom window must be installed to vent as shown and should not be rotated and used as a hopper.**

Details shown on pages 132-133.

Grille patterns shown on page 131.

\* "Transom Dimension" always refers to outside frame to frame dimension.  
 \*\* "Minimum Rough Opening" dimensions may need to be increased to allow for use of building wraps, flashing, sill panning, brackets, fasteners or other items. See installation information on page 170.  
 \* Dimensions in parentheses are in millimeters.

continued on next page



**Patio door sidelight and transom sizes on pages 126-130.**

5'-11 1/4" (1810)	6'-3 3/4" (1911)	6'-11 1/4" (2114)	7'-10 7/16" (2398)	7'-11 1/4" (2419)
6'-0" (1829)	6'-4" (1930)	7'-0" (2133)	7'-11" (2413)	8'-0" (2438)

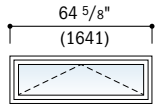

**ATV6020**

67 5/8" (1717)	71 5/8" (1818)	79 5/8" (2022)	90 3/4" (2305)	91 5/8" (2326)
-------------------	-------------------	-------------------	-------------------	-------------------

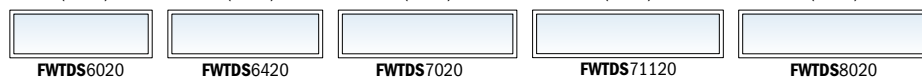

60" (1525)	64" (1626)	72" (1830)	83 3/16" (2113)	84" (2134)
---------------	---------------	---------------	--------------------	---------------

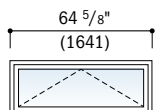
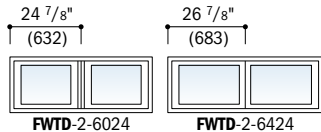

**ATV6024**

67 5/8" (1717)	71 5/8" (1818)	79 5/8" (2022)	90 3/4" (2305)	91 5/8" (2326)
-------------------	-------------------	-------------------	-------------------	-------------------

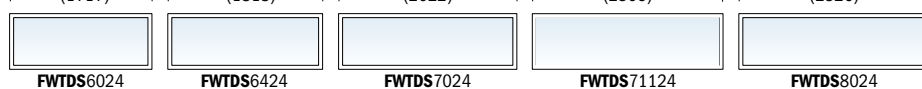

- \*"Transom Dimension" always refers to outside frame to frame dimension.
- \*\*"Minimum Rough Opening" dimensions may need to be increased to allow for use of building wraps, flashing, sill panning, brackets, fasteners or other items. See installation information on page 170.
- \*Dimensions in parentheses are in millimeters.



Custom-size patio door sidelight transoms and transom windows are available in 1/8" (3) increments. See pages 140 for custom sizes and specifications.

Choose patio door sash-set sidelight transom (**FWSLTD**), direct-set sidelight transom (**FWSTDS**), sash-set transom (**FWTD-1**, **FWTD-2**), direct-set transom (**FWTDS**), venting transom window (**ATV**) or patio door sidelights (shown on page 130).

Direct-set transom (**FWTDS**) provides maximum unobstructed glass. **Venting transom window must be installed to vent as shown and should not be rotated and used as a hopper.**

Details shown on pages 132-133.  
Grille patterns shown on page 131.

**Direct-Set Frenchwood® Patio Door Sidelight Transom & Transom Area Specifications** *(continued)*

Transom Number	Glass Area Sq. Ft./ (m <sup>2</sup> )	Overall Transom Area Sq. Ft./ (m <sup>2</sup> )
<b>FWTDS5414</b>	4.80 (0.45)	6.70 (0.62)
<b>FWTDS5418</b>	6.45 (0.60)	8.46 (0.79)
<b>FWTDS5420</b>	8.11 (0.75)	10.21 (0.95)
<b>FWTDS5424</b>	9.76 (0.91)	11.97 (1.11)
<b>FWTDS6010</b>	3.56 (0.33)	5.57 (0.52)
<b>FWTDS6014</b>	5.44 (0.51)	7.55 (0.70)
<b>FWTDS6018</b>	7.32 (0.68)	9.52 (0.88)
<b>FWTDS6020</b>	9.20 (0.85)	11.50 (1.07)
<b>FWTDS6024</b>	11.08 (1.03)	13.48 (1.25)
<b>FWTDS6410</b>	3.78 (0.35)	5.88 (0.55)
<b>FWTDS6414</b>	5.76 (0.54)	7.97 (0.74)
<b>FWTDS6418</b>	7.75 (0.72)	10.06 (0.93)
<b>FWTDS6420</b>	9.74 (0.90)	12.15 (1.13)
<b>FWTDS6424</b>	11.73 (1.09)	14.24 (1.32)
<b>FWTDS7010</b>	4.20 (0.39)	6.50 (0.60)
<b>FWTDS7014</b>	6.41 (0.60)	8.82 (0.82)

**Sash-Set Frenchwood® Patio Door Sidelight Transom & Transom Area Specifications**

Transom Number	Glass Area Sq. Ft./ (m <sup>2</sup> )	Overall Transom Area Sq. Ft./ (m <sup>2</sup> )
<b>FWTDS7018</b>	8.62 (0.80)	11.13 (1.03)
<b>FWTDS7020</b>	10.83 (1.01)	13.44 (1.25)
<b>FWTDS7024</b>	13.04 (1.21)	15.75 (1.46)
<b>FWTDS71110</b>	4.79 (0.44)	7.38 (0.69)
<b>FWTDS71114</b>	7.31 (0.68)	10.00 (0.93)
<b>FWTDS71118</b>	9.83 (0.91)	12.62 (1.17)
<b>FWTDS71120</b>	12.35 (1.15)	15.24 (1.42)
<b>FWTDS71124</b>	14.87 (1.38)	17.87 (1.66)
<b>FWTDS8010</b>	4.83 (0.45)	7.44 (0.69)
<b>FWTDS8014</b>	7.37 (0.68)	10.09 (0.94)
<b>FWTDS8018</b>	9.92 (0.92)	12.73 (1.18)
<b>FWTDS8020</b>	12.46 (1.16)	15.38 (1.43)
<b>FWTDS8024</b>	15.01 (1.39)	18.02 (1.67)

\*Dimensions in parentheses are in square meters.

Transom Number	Glass Area Sq. Ft./ (m <sup>2</sup> )	Overall Transom Area Sq. Ft./ (m <sup>2</sup> )
<b>FWSLTD1310</b>	0.15 (0.01)	1.11 (0.10)
<b>FWSLTD1314</b>	0.33 (0.03)	1.51 (0.14)
<b>FWSLTD1318</b>	0.51 (0.05)	1.90 (0.18)
<b>FWSLTD1320</b>	0.69 (0.06)	2.30 (0.21)
<b>FWSLTD1324</b>	0.86 (0.08)	2.70 (0.25)
<b>FWSLTD1710</b>	0.25 (0.02)	1.43 (0.13)
<b>FWSLTD1714</b>	0.54 (0.05)	1.93 (0.18)
<b>FWSLTD1718</b>	0.82 (0.08)	2.44 (0.23)
<b>FWSLTD1720</b>	1.11 (0.10)	2.95 (0.27)
<b>FWSLTD1724</b>	1.40 (0.13)	3.45 (0.32)
<b>FWTD-1-2110</b>	0.30 (0.03)	1.88 (0.17)
<b>FWTD-1-2114</b>	0.66 (0.06)	2.55 (0.24)
<b>FWTD-1-2118</b>	1.02 (0.09)	3.22 (0.30)

\*Dimensions in parentheses are in square meters.

*continued on next page*

**Table of Frenchwood® Patio Door Sidelight Sizes**

Scale 1/8" (3) = 1'-0" (305) – 1:96

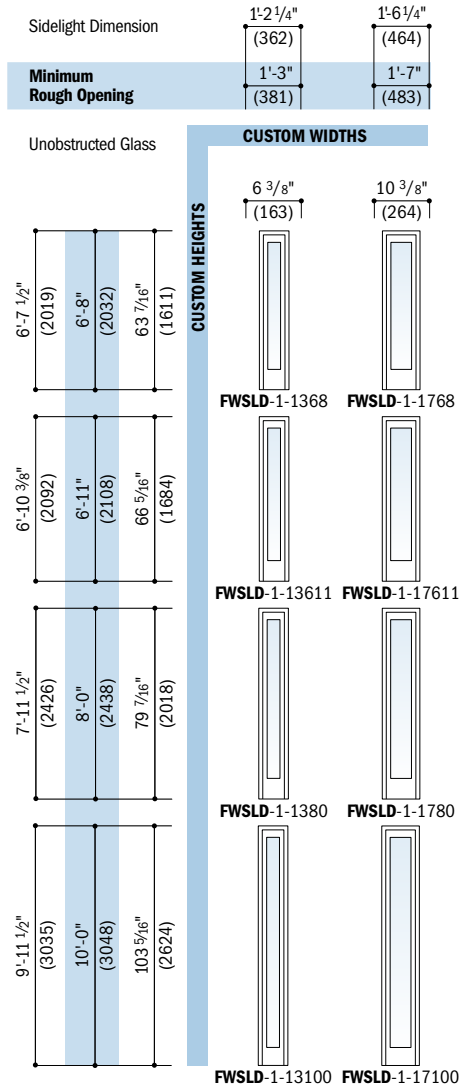

Custom-size patio door sidelights are available in 1/8" (3) increments. See page 140 for custom sizes and specifications.

Choose patio door sidelights (FWSLD), patio door transoms or venting transom windows (transoms shown on pages 126-129).

Details shown on pages 132-133.

Grille patterns shown on the next page.

Patio door sidelight and transom sizes on pages 126-130.

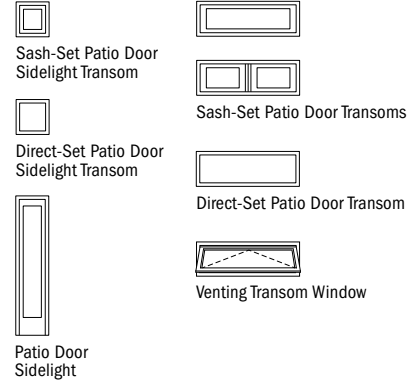

**Sash-Set Frenchwood® Patio Door Sidelight Transom & Transom Area Specifications** (continued)

Transom Number	Glass Area Sq. Ft./ (m <sup>2</sup> )	Overall Transom Area Sq. Ft./ (m <sup>2</sup> )
FWTD-1-2120	1.38 (0.13)	3.89 (0.36)
FWTD-1-2124	1.73 (0.16)	4.56 (0.42)
FWTD-1-2710	0.45 (0.04)	2.35 (0.22)
FWTD-1-2714	0.97 (0.09)	3.19 (0.30)
FWTD-1-2718	1.49 (0.14)	4.02 (0.37)
FWTD-1-2720	2.02 (0.19)	4.86 (0.45)
FWTD-1-2724	2.54 (0.24)	5.69 (0.53)
FWTD-1-2910	0.49 (0.05)	2.51 (0.23)
FWTD-1-2914	1.07 (0.10)	3.40 (0.32)
FWTD-1-2918	1.65 (0.15)	4.29 (0.40)
FWTD-1-2920	2.23 (0.21)	5.18 (0.48)
FWTD-1-2924	2.81 (0.26)	6.07 (0.56)
FWTD-1-3110	0.59 (0.05)	2.82 (0.26)
FWTD-1-3114	1.28 (0.12)	3.82 (0.35)
FWTD-1-3118	1.97 (0.18)	4.83 (0.45)
FWTD-1-3120	2.66 (0.25)	5.83 (0.54)
FWTD-1-3124	3.35 (0.31)	6.83 (0.63)
FWTD-1-3310	0.64 (0.06)	2.98 (0.28)
FWTD-1-3314	1.38 (0.13)	4.03 (0.37)
FWTD-1-3318	2.13 (0.20)	5.09 (0.47)
FWTD-1-3320	2.88 (0.27)	6.15 (0.57)
FWTD-1-3324	3.62 (0.34)	7.21 (0.67)
FWTD-1-4010	0.85 (0.08)	3.69 (0.34)
FWTD-2-4010	0.61 (0.06)	3.69 (0.34)
FWTD-1-4014	1.85 (0.17)	5.00 (0.46)
FWTD-2-4014	1.32 (0.12)	5.00 (0.46)
FWTD-1-4018	2.85 (0.26)	6.32 (0.59)
FWTD-2-4018	2.04 (0.19)	6.32 (0.59)
FWTD-1-4020	3.85 (0.36)	7.63 (0.71)
FWTD-2-4020	2.75 (0.26)	7.63 (0.71)
FWTD-1-4024	4.86 (0.45)	8.94 (0.83)
FWTD-2-4024	3.47 (0.32)	8.94 (0.83)
FWTD-1-5010	1.14 (0.11)	4.63 (0.43)
FWTD-2-5010	0.89 (0.08)	4.63 (0.43)
FWTD-1-5014	2.47 (0.23)	6.27 (0.58)

Transom Number	Glass Area Sq. Ft./ (m <sup>2</sup> )	Overall Transom Area Sq. Ft./ (m <sup>2</sup> )
FWTD-2-5014	1.94 (0.18)	6.27 (0.58)
FWTD-1-5018	3.80 (0.35)	7.92 (0.74)
FWTD-2-5018	2.99 (0.28)	7.92 (0.74)
FWTD-1-5020	5.14 (0.48)	9.57 (0.89)
FWTD-2-5020	4.04 (0.38)	9.57 (0.89)
FWTD-1-5024	6.47 (0.60)	11.21 (1.04)
FWTD-2-5024	5.09 (0.47)	11.21 (1.04)
FWTD-1-5410	1.23 (0.11)	4.94 (0.46)
FWTD-2-5410	0.99 (0.09)	4.94 (0.46)
FWTD-1-5414	2.68 (0.25)	6.70 (0.62)
FWTD-2-5414	2.15 (0.20)	6.70 (0.62)
FWTD-1-5418	4.12 (0.38)	8.46 (0.79)
FWTD-2-5418	3.31 (0.31)	8.46 (0.79)
FWTD-1-5420	5.57 (0.52)	10.21 (0.95)
FWTD-2-5420	4.47 (0.42)	10.21 (0.95)
FWTD-1-5424	7.01 (0.65)	11.97 (1.11)
FWTD-2-5424	5.63 (0.52)	11.97 (1.11)
FWTD-1-6010	1.42 (0.13)	5.57 (0.52)
FWTD-2-6010	1.18 (0.11)	5.57 (0.52)
FWTD-1-6014	3.09 (0.29)	7.55 (0.70)
FWTD-2-6014	2.56 (0.24)	7.55 (0.70)
FWTD-1-6018	4.75 (0.44)	9.52 (0.88)
FWTD-2-6018	3.94 (0.37)	9.52 (0.88)
FWTD-1-6020	6.42 (0.60)	11.50 (1.07)
FWTD-2-6020	5.32 (0.49)	11.50 (1.07)
FWTD-1-6024	8.09 (0.75)	13.48 (1.25)
FWTD-2-6024	6.70 (0.62)	13.48 (1.25)
FWTD-1-6410	1.51 (0.14)	5.88 (0.55)
FWTD-2-6410	1.27 (0.12)	5.88 (0.55)
FWTD-1-6414	3.29 (0.31)	7.97 (0.74)
FWTD-2-6414	2.76 (0.26)	7.97 (0.74)
FWTD-1-6418	5.07 (0.47)	10.06 (0.93)
FWTD-2-6418	4.26 (0.40)	10.06 (0.93)

\* "Sidelight Dimension" always refers to outside frame to frame dimension.  
 • "Minimum Rough Opening" dimensions may need to be increased to allow for use of building wraps, flashing, sill panning, brackets, fasteners or other items. See installation information on page 170.  
 • Dimensions in parentheses are in millimeters.

\* Dimensions in parentheses are in square meters.

continued on next page

**Sash-Set Frenchwood® Patio Door Sidelight Transom & Transom Area Specifications** *(continued)*

Transom Number	Glass Area		Overall Transom Area	
	Sq. Ft./	(m <sup>2</sup> )	Sq. Ft./	(m <sup>2</sup> )
FWTD-1-6420	6.85	(0.64)	12.15	(1.13)
FWTD-2-6420	5.75	(0.53)	12.15	(1.13)
FWTD-1-6424	8.63	(0.80)	14.24	(1.32)
FWTD-2-6424	7.24	(0.67)	14.24	(1.32)
FWTD-1-7010	1.70	(0.16)	6.50	(0.60)
FWTD-1-7014	3.70	(0.34)	8.82	(0.82)
FWTD-1-7018	5.71	(0.53)	11.13	(1.03)
FWTD-1-7020	7.71	(0.72)	13.44	(1.25)
FWTD-1-7024	9.71	(0.90)	15.75	(1.46)
FWTD-1-71110	1.97	(0.18)	7.38	(0.69)
FWTD-1-71114	4.28	(0.40)	10.00	(0.93)
FWTD-1-71118	6.59	(0.61)	12.62	(1.17)
FWTD-1-71120	8.90	(0.83)	15.24	(1.42)
FWTD-1-71124	11.21	(1.04)	17.87	(1.66)
FWTD-1-8010	1.99	(0.18)	7.44	(0.69)
FWTD-1-8014	4.32	(0.40)	10.09	(0.94)
FWTD-1-8018	6.66	(0.62)	12.73	(1.18)
FWTD-1-8020	8.99	(0.84)	15.38	(1.43)
FWTD-1-8024	11.32	(1.05)	18.02	(1.67)

\*Dimensions in parentheses are in square meters.

**Frenchwood® Patio Door Sidelight Area Specifications**

Sidelight Number	Glass Area		Overall Sidelight Area	
	Sq. Ft./	(m <sup>2</sup> )	Sq. Ft./	(m <sup>2</sup> )
FWSLD1368	2.82	(0.26)	7.87	(0.73)
FWSLD13611	2.95	(0.27)	8.15	(0.76)
FWSLD1380	3.53	(0.33)	9.45	(0.88)
FWSLD13100	4.60	(0.43)	11.83	(1.10)
FWSLD1768	4.58	(0.43)	10.08	(0.94)
FWSLD17611	4.79	(0.44)	10.44	(0.97)
FWSLD1780	5.74	(0.53)	12.10	(1.12)
FWSLD17100	7.47	(0.69)	15.14	(1.41)

\*Dimensions in parentheses are in square meters.

**Venting Transom Window Opening and Area Specifications**

Window Number	Clear Opening		Clear Opening in Full Open Position		Glass Area	Vent	Top of Subfloor to Top of Inside Sill Stop	Overall Window Area
	Sq. Ft./	(m <sup>2</sup> )	Width Inches/(mm)	Depth Inches/(mm)				
ATV2114	0.79	(0.07)	19 3/16" (487)	5 7/8" (149)	1.04 (0.10)	0.79 (0.07)	69 1/2" (1765)	2.56 (0.24)
ATV2714	1.03	(0.10)	25 3/16" (640)	5 7/8" (149)	1.40 (0.13)	1.03 (0.10)	69 1/2" (1765)	3.19 (0.30)
ATV2914	1.11	(0.10)	27 3/16" (691)	5 7/8" (149)	1.52 (0.14)	1.11 (0.10)	69 1/2" (1765)	3.40 (0.32)
ATV3114	1.28	(0.12)	31 3/16" (792)	5 7/8" (149)	1.76 (0.16)	1.28 (0.12)	69 1/2" (1765)	3.83 (0.36)
ATV3314	1.36	(0.13)	33 3/16" (843)	5 7/8" (149)	1.88 (0.17)	1.36 (0.13)	69 1/2" (1765)	4.04 (0.38)
ATV4014	1.73	(0.16)	42 3/16" (1075)	5 7/8" (149)	2.43 (0.23)	1.73 (0.16)	69 1/2" (1765)	5.00 (0.46)
ATV5014	2.22	(0.21)	54 3/16" (1380)	5 7/8" (149)	3.14 (0.29)	2.22 (0.21)	69 1/2" (1765)	6.28 (0.58)
ATV5414	2.39	(0.22)	58 3/16" (1481)	5 7/8" (149)	3.38 (0.31)	2.39 (0.22)	69 1/2" (1765)	6.70 (0.62)
ATV6014	2.71	(0.25)	66 3/16" (1684)	5 7/8" (149)	3.86 (0.36)	2.71 (0.25)	69 1/2" (1765)	7.55 (0.70)
ATV2118	0.79	(0.07)	19 3/16" (487)	5 7/8" (149)	1.53 (0.14)	0.79 (0.07)	65 1/2" (1664)	3.23 (0.30)
ATV2718	1.03	(0.10)	25 3/16" (640)	5 7/8" (149)	2.05 (0.19)	1.03 (0.10)	65 1/2" (1664)	4.03 (0.37)
ATV2918	1.11	(0.10)	27 3/16" (691)	5 7/8" (149)	2.23 (0.21)	1.11 (0.10)	65 1/2" (1664)	4.29 (0.40)
ATV3118	1.28	(0.12)	31 3/16" (792)	5 7/8" (149)	2.58 (0.24)	1.28 (0.12)	65 1/2" (1664)	4.83 (0.45)
ATV3318	1.36	(0.13)	33 3/16" (843)	5 7/8" (149)	2.75 (0.26)	1.36 (0.13)	65 1/2" (1664)	5.10 (0.47)
ATV4018	1.73	(0.16)	42 3/16" (1075)	5 7/8" (149)	3.55 (0.33)	1.73 (0.16)	65 1/2" (1664)	6.32 (0.59)
ATV5018	2.22	(0.21)	54 3/16" (1380)	5 7/8" (149)	4.60 (0.43)	2.22 (0.21)	65 1/2" (1664)	7.92 (0.74)
ATV5418	2.39	(0.22)	58 3/16" (1481)	5 7/8" (149)	4.95 (0.46)	2.39 (0.22)	65 1/2" (1664)	8.46 (0.79)
ATV6018	2.71	(0.25)	66 3/16" (1684)	5 7/8" (149)	5.65 (0.52)	2.71 (0.25)	65 1/2" (1664)	9.53 (0.89)
ATV2120	0.79	(0.07)	19 3/16" (487)	5 7/8" (149)	2.01 (0.19)	0.79 (0.07)	61 1/2" (1562)	3.90 (0.36)
ATV2720	1.03	(0.10)	25 3/16" (640)	5 7/8" (149)	2.71 (0.25)	1.03 (0.10)	61 1/2" (1562)	4.86 (0.45)
ATV2920	1.11	(0.10)	27 3/16" (691)	5 7/8" (149)	2.94 (0.27)	1.11 (0.10)	61 1/2" (1562)	5.19 (0.48)
ATV3120	1.28	(0.12)	31 3/16" (792)	5 7/8" (149)	3.40 (0.32)	1.28 (0.12)	61 1/2" (1562)	5.83 (0.54)
ATV3320	1.36	(0.13)	33 3/16" (843)	5 7/8" (149)	3.63 (0.34)	1.36 (0.13)	61 1/2" (1562)	6.16 (0.57)
ATV4020	1.73	(0.16)	42 3/16" (1075)	5 7/8" (149)	4.68 (0.44)	1.73 (0.16)	61 1/2" (1562)	7.63 (0.71)
ATV5020	2.22	(0.21)	54 3/16" (1380)	5 7/8" (149)	6.06 (0.56)	2.22 (0.21)	61 1/2" (1562)	9.57 (0.89)
ATV5420	2.39	(0.22)	58 3/16" (1481)	5 7/8" (149)	6.53 (0.61)	2.39 (0.22)	61 1/2" (1562)	10.21 (0.95)
ATV6020	2.71	(0.25)	66 3/16" (1684)	5 7/8" (149)	7.45 (0.69)	2.71 (0.25)	61 1/2" (1562)	11.07 (1.01)
ATV2124	0.79	(0.07)	19 3/16" (487)	5 7/8" (149)	2.50 (0.23)	0.79 (0.07)	57 1/2" (1461)	4.57 (0.42)
ATV2724	1.03	(0.10)	25 3/16" (640)	5 7/8" (149)	3.36 (0.31)	1.03 (0.10)	57 1/2" (1461)	5.70 (0.53)
ATV2924	1.11	(0.10)	27 3/16" (691)	5 7/8" (149)	3.64 (0.34)	1.11 (0.10)	57 1/2" (1461)	6.08 (0.56)
ATV3124	1.28	(0.12)	31 3/16" (792)	5 7/8" (149)	4.22 (0.39)	1.28 (0.12)	57 1/2" (1461)	6.84 (0.64)
ATV3324	1.36	(0.13)	33 3/16" (843)	5 7/8" (149)	4.50 (0.42)	1.36 (0.13)	57 1/2" (1461)	7.23 (0.67)
ATV4024	1.73	(0.16)	42 3/16" (1075)	5 7/8" (149)	5.81 (0.54)	1.73 (0.16)	57 1/2" (1461)	8.94 (0.83)
ATV5024	2.22	(0.21)	54 3/16" (1380)	5 7/8" (149)	7.53 (0.70)	2.22 (0.21)	57 1/2" (1461)	11.21 (1.04)
ATV5424	2.39	(0.22)	58 3/16" (1481)	5 7/8" (149)	8.10 (0.75)	2.39 (0.22)	57 1/2" (1461)	11.97 (1.11)
ATV6024	2.71	(0.25)	66 3/16" (1684)	5 7/8" (149)	9.24 (0.86)	2.71 (0.25)	57 1/2" (1461)	13.49 (1.25)

\*Top of Subfloor to Top of Inside Sill Stop" is calculated based upon a structural header height of 6'-10 1/2" (2096).  
\*Dimensions in parentheses are in millimeters or square meters.

**Grille Patterns**

	Queen Anne	Diamond	Prairie A	Colonial
<b>Frenchwood® Patio Door Transoms</b>				
<b>Frenchwood® Patio Door Sidelights</b>				

**Number of lights and overall pattern varies with window size. Patterns shown may not be available for all sizes.** Specified equal light and custom patterns are also available. For more information on divided light, see page 15 or visit [andersenwindows.com/grilles](http://andersenwindows.com/grilles).

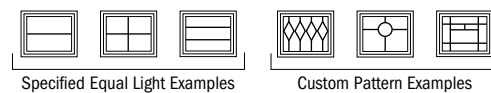

**Direct-Set Frenchwood® Patio Door Sidelight Transom and Transom Details**

Scale 1 1/2" (38) = 1'-0" (305) – 1:8

**Venting Transom Window Details**

Scale 1 1/2" (38) = 1'-0" (305) – 1:8

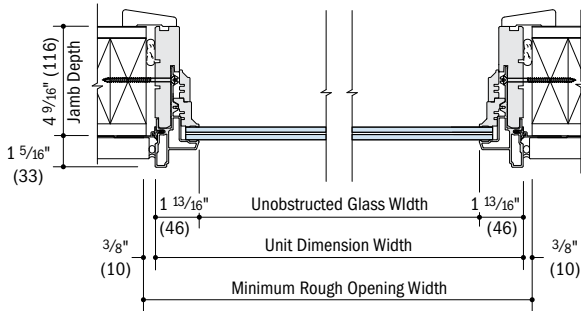

**Horizontal Section**  
Monolithic SmartSun™ Impact-Resistant Glass

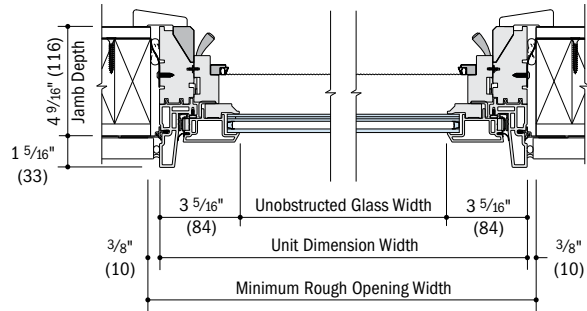

**Horizontal Section**  
Low-E4™ Impact-Resistant Glass\*

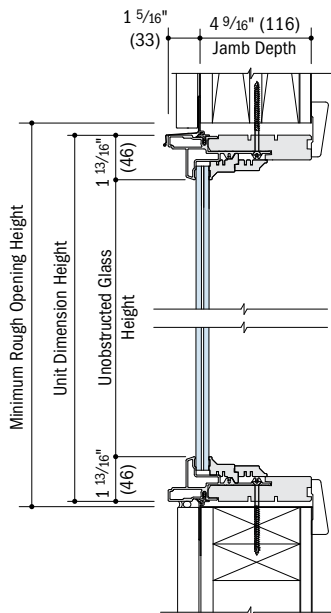

**Vertical Section**  
Monolithic SmartSun™ Impact-Resistant Glass

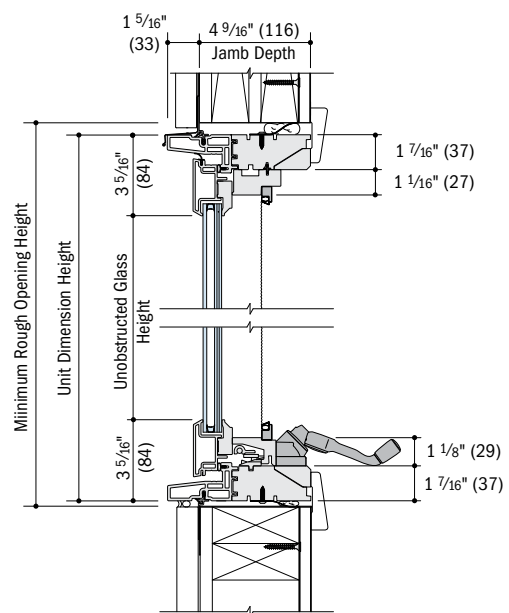

**Vertical Section**  
Low-E4™ Impact-Resistant Glass\*

- \* 4 9/16" (116) jamb depth measurement is from back side of installation flange.
- Light-colored areas are parts included with window. Dark-colored areas are additional Andersen® parts required to complete window assembly as shown.
- Dimensions in parentheses are in millimeters.
- **Minimum rough opening dimensions may need to be increased to allow for use of building wraps, flashing, sill panning, brackets, fasteners or other items. See installation information on page 170.**
- Details are for illustration only and are not intended to represent product installation methods or materials. Refer to product installation guides at [andersenwindows.com](http://andersenwindows.com).
- \*Venting transom windows with Stormwatch® Protection are not available with monolithic SmartSun impact-resistant glass.

**Sash-Set Frenchwood® Patio Door Sidelight, Sidelight Transom and Transom Details**

Scale 1 1/2" (38) = 1'-0" (305) – 1:8

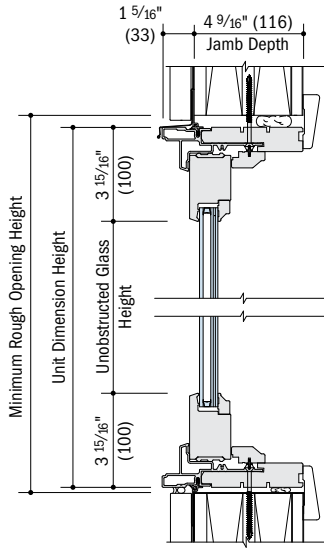

**Vertical Section**

Sidelight Transom and Transom – Low-E4® Impact-Resistant Glass

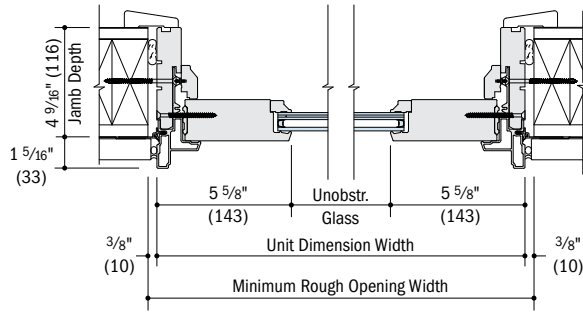

**Horizontal Section**

Transom – Low-E4® Impact-Resistant Glass

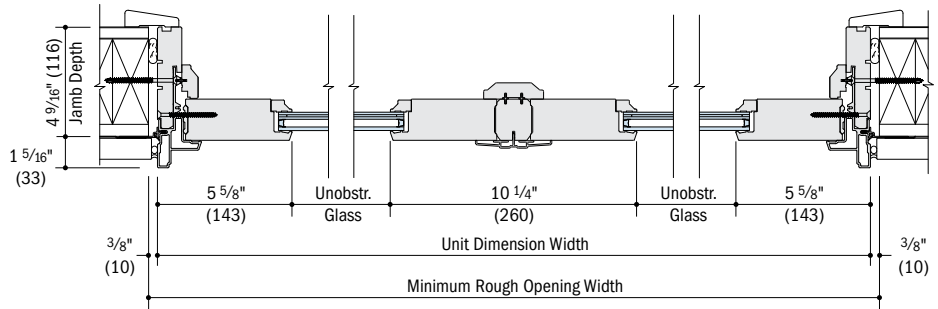

**Horizontal Section**

Twin Transom – Low-E4® Impact-Resistant Glass

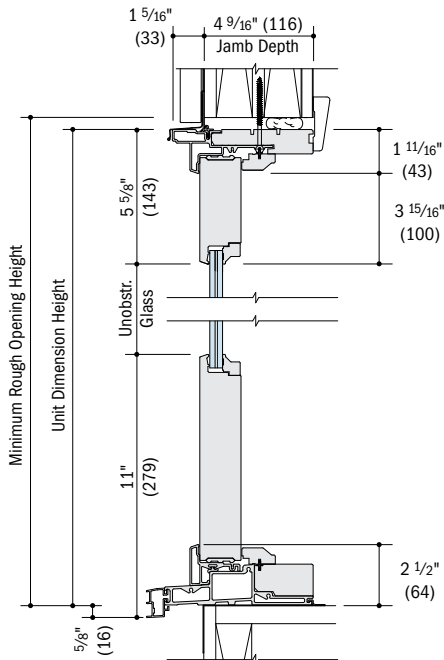

**Vertical Section**

Sidelight – Monolithic SmartSun™ Impact-Resistant Glass

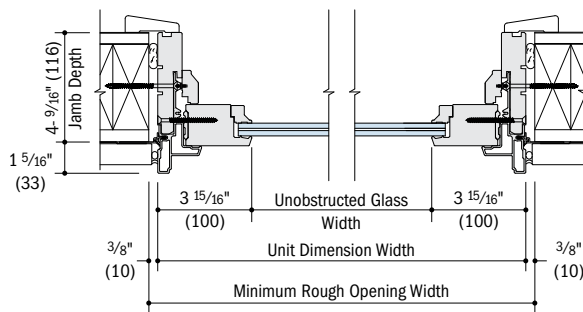

**Horizontal Section**

Sidelight and Sidelight Transom – Monolithic SmartSun™ Impact-Resistant Glass

**See pages 134-137 for horizontal and vertical joining details.**

- 4 9/16" (116) jamb depth measurement is from back side of installation flange.
- Light-colored areas are parts included with window. Dark-colored areas are additional Andersen® parts required to complete window assembly as shown.
- Dimensions in parentheses are in millimeters.
- **Minimum rough opening dimensions may need to be increased to allow for use of building wraps, flashing, sill panning, brackets, fasteners or other items. See installation information on page 170.**
- Details are for illustration only and are not intended to represent product installation methods or materials. Refer to product installation guides at [andersenwindows.com](http://andersenwindows.com).

**Vertical (ribbon) 4 9/16" (116) and 6 9/16" (167) Fiberglass Joining Details**

Scale 1 1/2" (38) = 1'-0" (305) – 1:8

Doors, sidelights and transoms can be joined using 3/4" (19) x 5 3/4" (146) fiberglass joining material for 4 9/16" (116) minimum wall depth. 3/4" (19) x 7 3/4" (197) fiberglass joining material is used for higher performance and it is required for Frenchwood® hinged inswing patio doors with 6 9/16" (167) base jamb depths.

**Do not join inswing or outswing doors hinge jamb to hinge jamb. For more joining information, see the combination designs section starting on page 148.**

**Frenchwood® Hinged Inswing Patio Doors**

**Overall "Door to Door" or "Door to Sidelight" Dimension Width** Sum of individual "door to door" or "door to sidelight" widths plus 3/4" (19).

**Overall Minimum Rough Opening Width** Overall dimension width plus 3/4" (19).

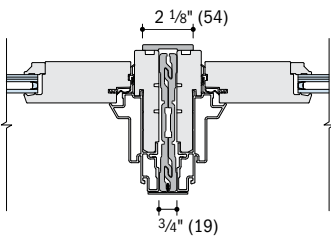

**Stationary Jamb to Stationary Jamb**  
4 9/16" (116) Jamb Depth

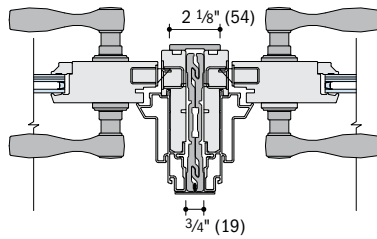

**Latch Jamb to Latch Jamb**  
4 9/16" (116) Jamb Depth

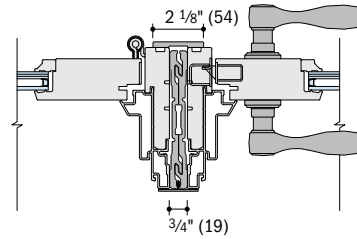

**Hinge Jamb to Latch Jamb**  
4 9/16" (116) Jamb Depth

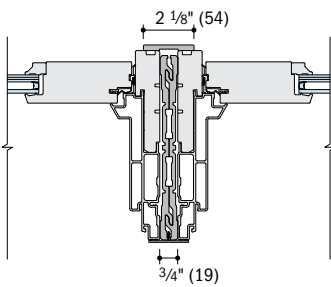

**Stationary Jamb to Stationary Jamb**  
6 9/16" (167) Jamb Depth

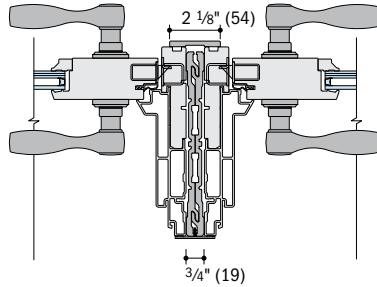

**Latch Jamb to Latch Jamb**  
6 9/16" (167) Jamb Depth

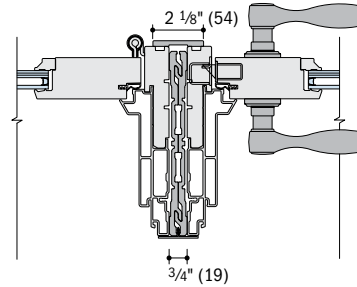

**Hinge Jamb to Latch Jamb**  
6 9/16" (167) Jamb Depth

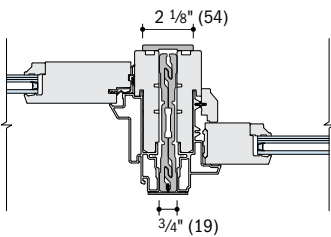

**Stationary Jamb to Sidelight**  
4 9/16" (116) Jamb Depth

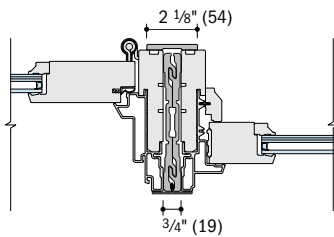

**Hinge Jamb to Sidelight**  
4 9/16" (116) Jamb Depth

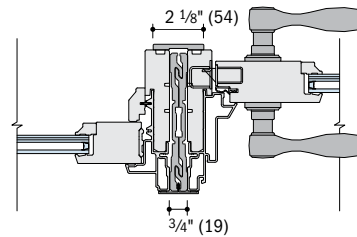

**Sidelight to Latch Jamb**  
4 9/16" (116) Jamb Depth

• Light-colored areas are parts included with window. Dark-colored areas are additional Andersen® parts required to complete window assembly as shown.

• Dimensions in parentheses are in millimeters.

• **Minimum rough opening dimensions may need to be increased to allow for use of building wraps, flashing, sill panning, brackets, fasteners or other items. See installation information on page 170.**

• Details are for illustration only and are not intended to represent product installation methods or materials. Refer to product installation guides at andersenwindows.com.

• Structural performance of any combination is only as high as the lowest structural performance of any individual door or join in the combination.

• Andersen® products must be installed and anchored properly according to joining and installation guides to meet rated structural performance. Refer to product joining and installation guides at andersenwindows.com.

**Frenchwood® Hinged Outswing Patio Doors**

**Overall "Door to Door" or "Door to Sidelight" Dimension Width** Sum of individual "door to door" or "door to sidelight" widths plus 3/4" (19).

**Overall Minimum Rough Opening Width** Overall dimension width plus 3/4" (19).

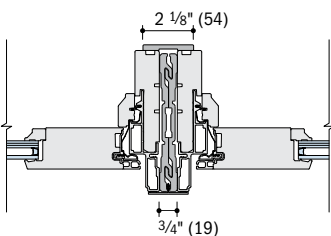

**Stationary Door to Stationary Door**

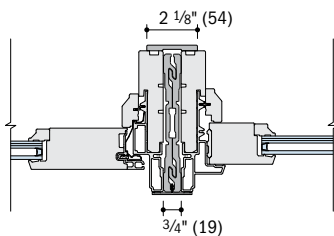

**Stationary Door to Sidelight**

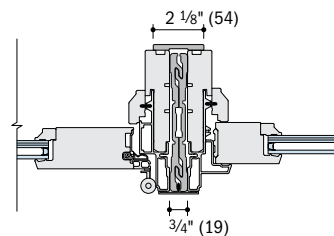

**Hinge Jamb to Sidelight**



### Vertical (ribbon) 4 9/16" (116) Fiberglass Joining Details

Scale 1 1/2" (38) = 1'-0" (305) – 1:8

#### Frenchwood® Gliding Patio Doors

**Overall "Door to Door" or "Door to Sidelight" Dimension Width** Sum of individual "door to door" or "door to sidelight" widths plus 3/4" (19).

**Overall Minimum Rough Opening Width** Overall dimension width plus 3/4" (19).

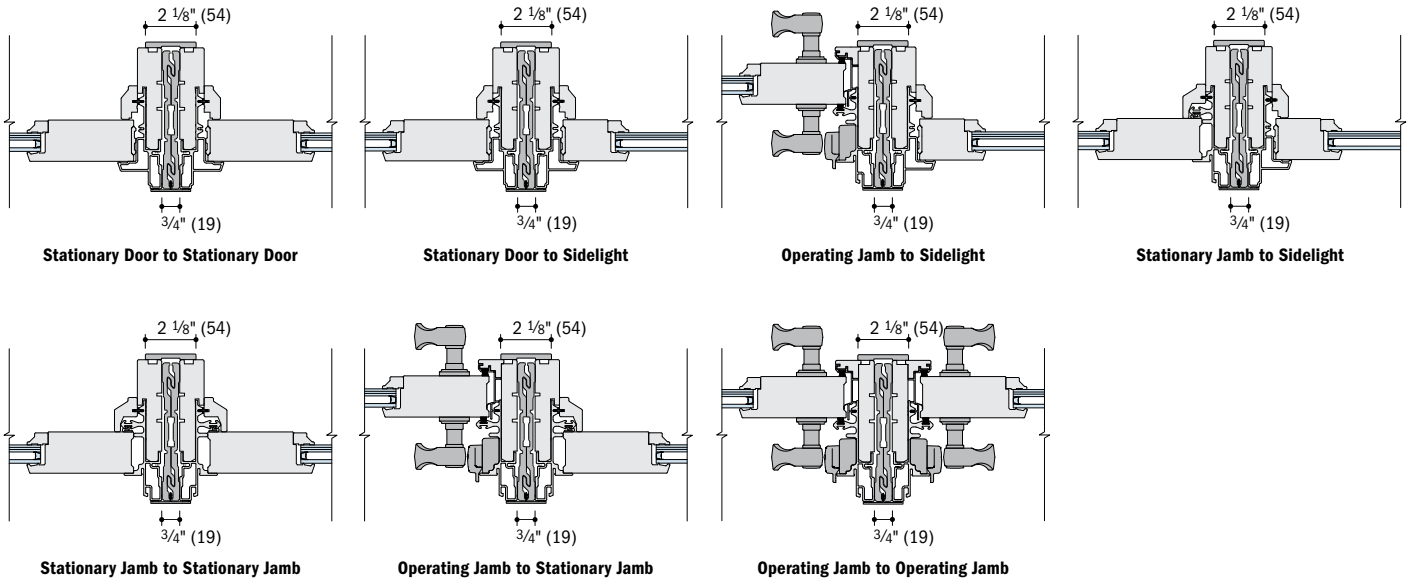

#### Frenchwood® Patio Door Sidelights, Sidelight Transoms, Transoms and Venting Transom Windows

**Overall "Transom to Transom" or "Transom to Sidelight Transom" Dimension Width** Sum of individual "transom to transom" or "transom to sidelight transom" widths plus 3/4" (19).

**Overall Minimum Rough Opening Width** Overall dimension width plus 3/4" (19).

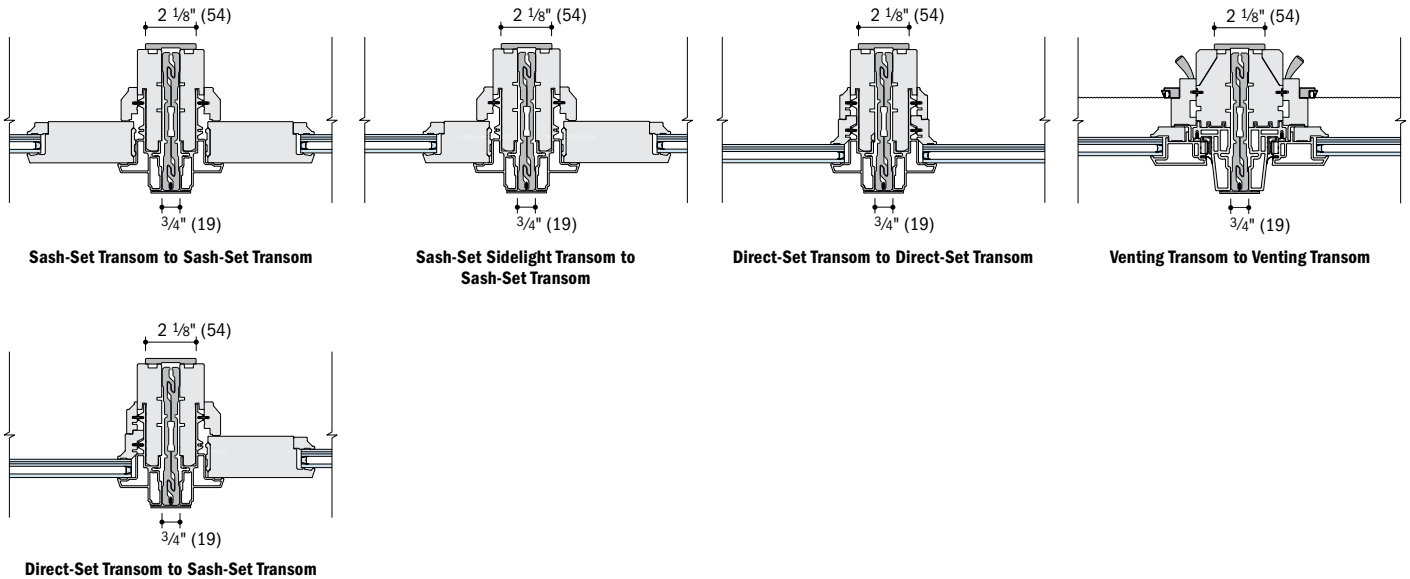

- Light-colored areas are parts included with window. Dark-colored areas are additional Andersen® parts required to complete window assembly as shown.
- Dimensions in parentheses are in millimeters.
- **Minimum rough opening dimensions may need to be increased to allow for use of building wraps, flashing, sill panning, brackets, fasteners or other items. See installation information on page 170.**
- Details are for illustration only and are not intended to represent product installation methods or materials. Refer to product installation guides at andersenwindows.com.
- Structural performance of any combination is only as high as the lowest structural performance of any individual door or join in the combination.
- Andersen® products must be installed and anchored properly according to joining and installation guides to meet rated structural performance. Refer to product joining and installation guides at andersenwindows.com.

Transom Options

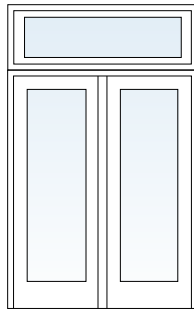

Sash-Set  
Frenchwood® Patio Door  
Transom

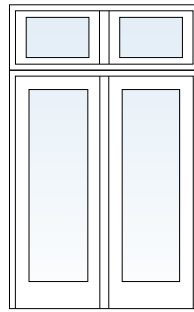

Sash-Set  
Frenchwood® Patio Door  
Twin Transom

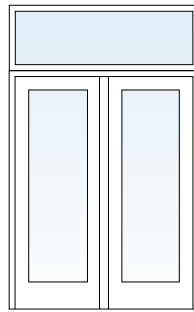

Direct-Set  
Frenchwood® Patio Door  
Transom

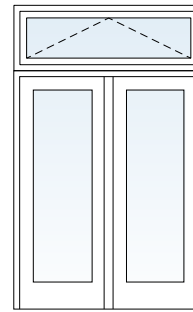

Venting Transom Window

Horizontal (stack) 4 9/16" (116) Fiberglass Joining Details

Scale 1 1/2" (38) = 1'-0" (305) – 1:8

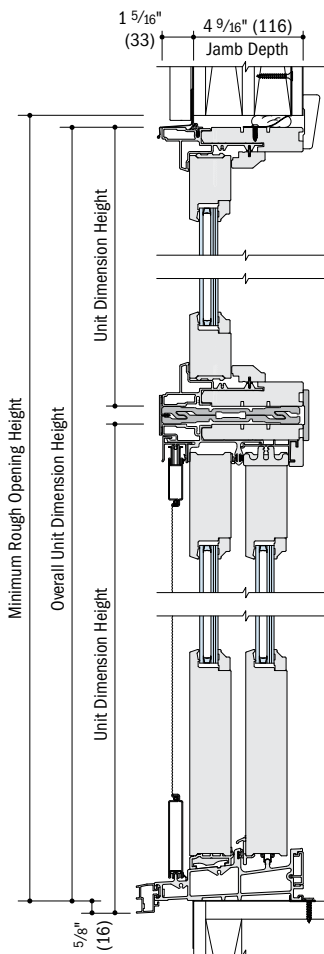

Sash-Set  
Frenchwood® Patio Door Transom over  
Frenchwood® Gliding Patio Door

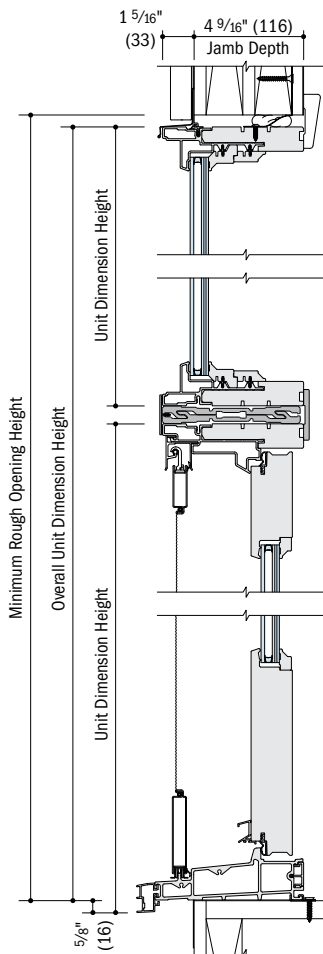

Direct-Set  
Frenchwood® Patio Door Transom over  
Frenchwood® Hinged Inswing Patio Door

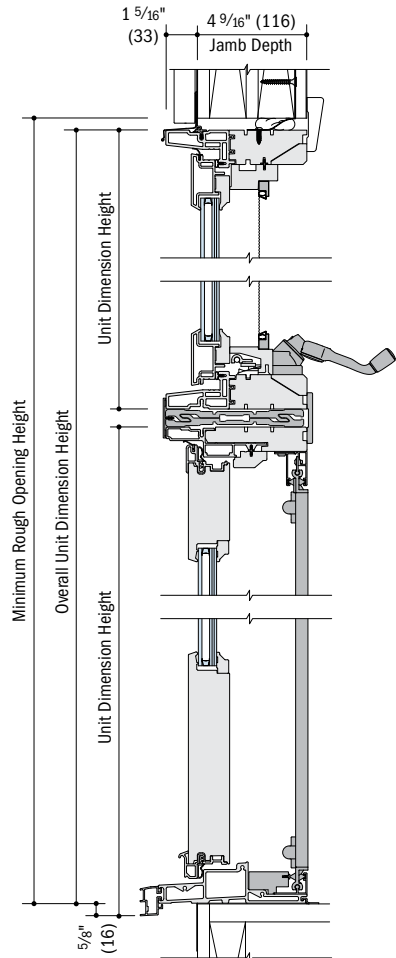

Venting Transom Window over  
Frenchwood® Hinged Outswing Patio Door

\* Light-colored areas are parts included with window. Dark-colored areas are additional Andersen® parts required to complete window assembly as shown.  
\* Dimensions in parentheses are in millimeters.

\* **Minimum rough opening dimensions may need to be increased to allow for use of building wraps, flashing, sill panning, brackets, fasteners or other items. See installation information on page 170.**

\* Details are for illustration only and are not intended to represent product installation methods or materials. Refer to product installation guides at andersenwindows.com.

\* Structural performance of any combination is only as high as the lowest structural performance of any individual door or join in the combination.

\* Andersen® products must be installed and anchored properly according to joining and installation guides to meet rated structural performance. Refer to product joining and installation guides at andersenwindows.com.

**Horizontal (stack) 4 9/16" (116) Fiberglass Joining Details**

Scale 1 1/2" (38) = 1'-0" (305) – 1:8

**Overall "Transom over Door" or "Sidelight Transom over Sidelight" Dimension Height** Sum of individual "transom over door" or "sidelight transom over sidelight" heights plus 3/4" (19).

**Overall Minimum Rough Opening Height** Overall dimension height plus 1/2" (13).

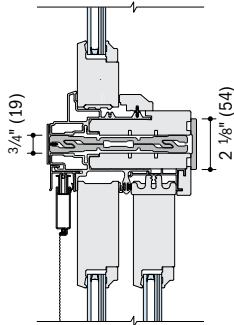

**Sash-Set**  
**Frenchwood® Patio Door Transom over**  
**Frenchwood® Gliding Patio Door**

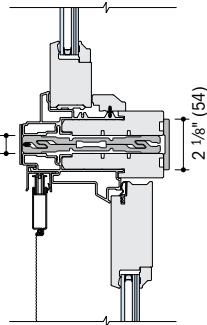

**Sash-Set**  
**Frenchwood® Patio Door Transom over**  
**Frenchwood® Hinged Inswing Patio Door**

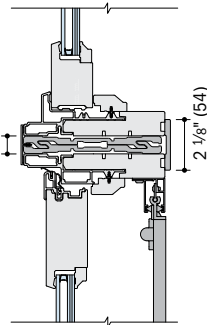

**Sash-Set**  
**Frenchwood® Patio Door Transom over**  
**Frenchwood® Hinged Outswing Patio Door**

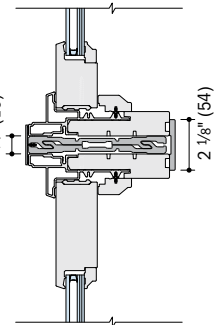

**Sash-Set**  
**Frenchwood® Patio Door Sidelight Transom**  
**over Frenchwood® Patio Door Sidelight**

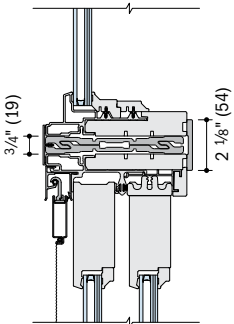

**Direct-Set**  
**Frenchwood® Patio Door Transom over**  
**Frenchwood® Gliding Patio Door**

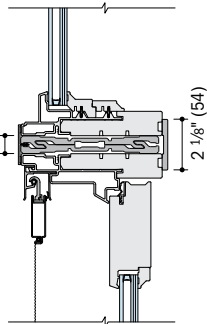

**Direct-Set**  
**Frenchwood® Patio Door Transom over**  
**Frenchwood® Hinged Inswing Patio Door**

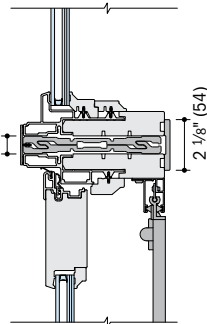

**Direct-Set**  
**Frenchwood® Patio Door Transom over**  
**Frenchwood® Hinged Outswing Patio Door**

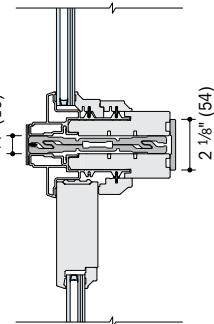

**Direct-Set**  
**Frenchwood® Patio Door Sidelight Transom**  
**over Frenchwood® Patio Door Sidelight**

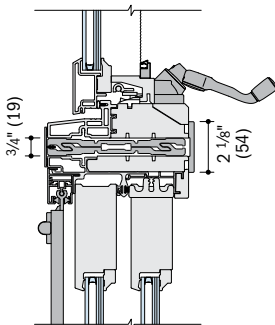

**Venting Transom Window over**  
**Frenchwood® Gliding Patio Door**

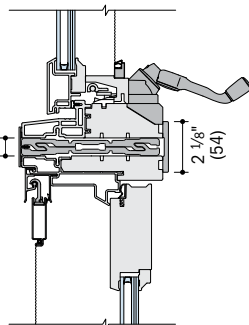

**Venting Transom Window over**  
**Frenchwood® Hinged Inswing Patio Door**

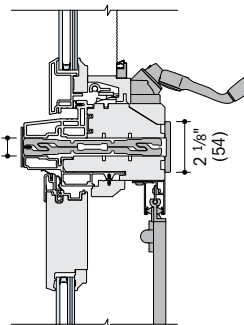

**Venting Transom Window over**  
**Frenchwood® Hinged Outswing Patio Door**

**For more joining information, see the combination designs section starting on page 148.**

- Light-colored areas are parts included with window. Dark-colored areas are additional Andersen® parts required to complete window assembly as shown.
- Dimensions in parentheses are in millimeters.
- **Minimum rough opening dimensions may need to be increased to allow for use of building wraps, flashing, sill panning, brackets, fasteners or other items. See installation information on page 170.**
- Details are for illustration only and are not intended to represent product installation methods or materials. Refer to product installation guides at andersenwindows.com.
- Structural performance of any combination is only as high as the lowest structural performance of any individual door or join in the combination.
- Andersen® products must be installed and anchored properly according to joining and installation guides to meet rated structural performance. Refer to product joining and installation guides at andersenwindows.com.

Custom Sizes & Specification Formulas



Frenchwood® Gliding Patio Doors

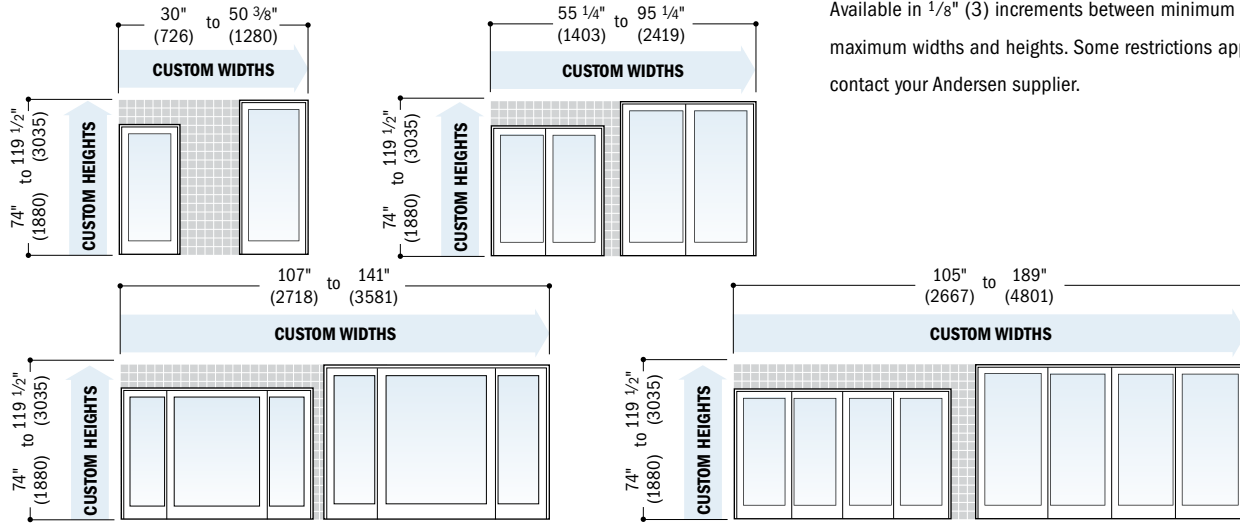

Available in 1/8" (3) increments between minimum and maximum widths and heights. Some restrictions apply, contact your Andersen supplier.

Clear Opening	Two-Panel	Minimum R.O.	Single-Panel	Unobstr. Glass	Single-Panel
	Width = (door width + 2) - 8.368" Height = door height - 3.927" (98)		Width = door width + 3/4" (19) Height = door height + 1/2" (13)		Width = door width - 11.22" (285) Height = door height - 16.06" (408)
	<b>Three-Panel, one panel open</b> Width = (door width + 4) - 7.993" (203) Height = door height - 3.927" (100)		<b>Two-Panel</b> Width = door width + 3/4" (19) Height = door height + 1/2" (13)		<b>Two-Panel</b> Width = door width - 17.00" (432) Height = door height - 16.06" (408)
	<b>Four-Panel, two panels open</b> Width = (door width + 2) - 15.458" (393) Height = door height - 3.927" (100)		<b>Three-Panel</b> Width = door width + 1" (25) Height = door height + 1/2" (13)		<b>Three-Panel</b> Width = door width - 22.78" (579) Height = door height - 16.06" (408)
			<b>Four-Panel</b> Width = door width + 1" (25) Height = door height + 1/2" (13)		<b>Four-Panel</b> Width = door width - 11.22" (285) Height = door height - 16.06" (408)

Frenchwood® Hinged Inswing Patio Doors

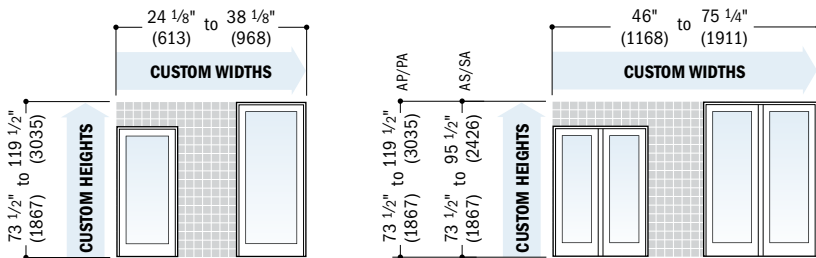

Clear Opening	Single-Panel	Minimum R.O.	Single-Panel	Unobstr. Glass	Single-Panel
	Height = door height - 4.232" (107)		Width = door width + 3/4" (19) Height = door height + 1/2" (13)		Width = door width - 11.22" (285) Height = door height - 16.06" (408)
	<b>Two-Panel, two panels open</b> Width = door width - 7.477" (190)		<b>Two-Panel</b> Width = door width + 3/4" (19) Height = door height + 1/2" (13)		<b>Two-Panel</b> Width = door width - 21.50" (546) Height = door height - 16.06" (408)
	<b>Two-Panel, one panel open</b> Width = (door width - 8.992" (228)) + 2				

• Clear opening formulas based on door(s) in 90 degree open position.

• Dimensions in parentheses are in millimeters.

• "Clear Opg." (clear opening) formulas provide dimensions for determining area available for egress. "Vent Opg." (vent opening) formulas provide dimensions for determining area available for passage of air. "Min. R.O." (minimum rough opening) formulas provide minimum rough opening width and height dimensions. "Unobstr. Gls." (unobstructed glass) formulas provide dimensions for determining area available for passage of light.

**Frenchwood® Hinged Outswing Patio Doors**

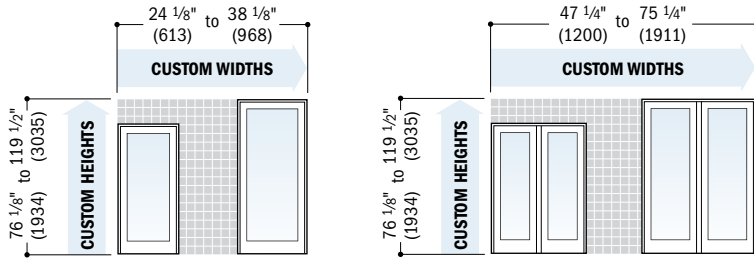

Clear Opening	Height = door height - 3.418" (87)	Minimum R.O.	Single-Panel	Unobstr. Glass	Single-Panel
	Single-Panel Width = door width - 5.04" (128)		Width = door width + 3/4" (19) Height = door height + 1/2" (13)		Width = door width - 11.22" (285) Height = door height - 16.06" (408)
	Two-Panel, two panels open Width = door width - 6.69" (170)		Two-Panel Width = door + 3/4" (19) Height = door + 1/2" (13)		Two-Panel Width = door width - 21.50" (546) Height = door height - 16.06" (408)
	Two-Panel, one panel open Width = (door width - 9.959" (253)) ÷ 2				

\*Clear opening formulas based on door(s) in 90 degree open position.

**Frenchwood® Patio Door Sidelights**

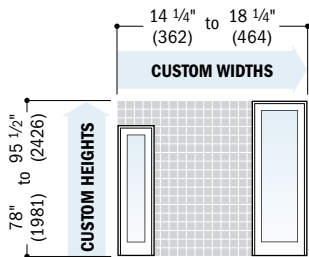

Minimum R.O.	Sidelight	Unobstr. Glass	Sidelight
	Width = sidelight width + 3/4" (19) Height = sidelight height + 1/2" (13)		Width = sidelight width - 7.84" (199) Height = sidelight height - 16.06" (408)

**Custom-Size Frenchwood® Patio Door Shipping Information**

	DOOR PRODUCT TYPE & SIZE		FACTORY-ASSEMBLED	UNASSEMBLED with Assembled Frame <small>Panels ship separately</small>	UNASSEMBLED with Unassembled Frame <small>Panels ship separately</small>
	PATIO DOOR HEIGHT EQUAL TO OR LESS THAN 95 1/2"	1-panel	gliding	√	
1-panel		hinged	√		
2-panel		gliding	√		√
2-panel		hinged	√		
4-panel		gliding			√
3-panel		hinged	√		
PATIO DOOR HEIGHT GREATER THAN 95 1/2"	1-panel	gliding	√		
	1-panel	hinged	√		
	2-panel	gliding			√
	2-panel*	hinged		√	
	4-panel	gliding			√

\*Two-panel patio doors over 95 1/2" (2426) tall are only available active-passive or passive-active (AP/PA).

\*Dimensions in parentheses are in millimeters.

\*\*"Clear Opg." (clear opening) formulas provide dimensions for determining area available for egress. "Vent Opg." (vent opening) formulas provide dimensions for determining area available for passage of air. "Min. R.O." (minimum rough opening) formulas provide minimum rough opening width and height dimensions. "Unobstr. Gls." (unobstructed glass) formulas provide dimensions for determining area available for passage of light.

**Frenchwood® Patio Door Sidelight Transoms**

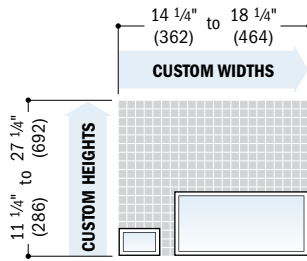

<b>Minimum R.O.</b> 	<b>Sash-Set Sidelight Transom</b> Width = transom width + 3/4" (19) Height = transom height + 3/4" (19)	<b>Unobstr. Glass</b> 	<b>Sash-Set Sidelight Transom</b> Width = transom width - 7.84" (199) Height = transom height - 7.84" (199)
	<b>Direct-Set Sidelight Transom</b> Width = transom width + 3/4" (19) Height = transom height + 3/4" (19)		<b>Direct-Set Sidelight Transom</b> Width = transom width - 3.66" (93) Height = transom height - 3.66" (93)

**Frenchwood® Patio Door Transoms**

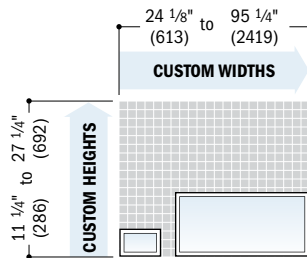

For custom sizes and specification formulas for venting transom windows, see page 62.

<b>Minimum R.O.</b> 	<b>Sash-Set Transom</b> Width = transom width + 3/4" (19) Height = transom height + 3/4" (19)	<b>Unobstr. Glass</b> 	<b>Sash-Set Transom</b> Width = transom width - 11.22" (285) Height = transom height - 7.84" (199)
	<b>Direct-Set Transom</b> Width = transom width + 3/4" (19) Height = transom height + 3/4" (19)		<b>Direct-Set Transom</b> Width = transom width - 3.66" (93) Height = transom height - 3.66" (93)

**Frenchwood® Patio Door Twin Transoms**

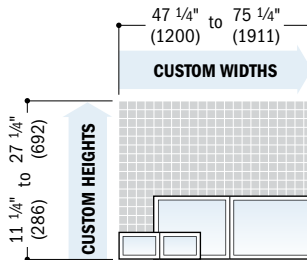

<b>Minimum R.O.</b> 	<b>Twin</b> Width = transom width + 3/4" (19) Height = transom height + 3/4" (19)	<b>Unobstr. Glass</b> 	<b>Twin</b> Width = transom width - 21.5" (546) Height = transom height - 7.84" (199)
	<b>Triple</b> Width = transom width + 3/4" (19) Height = transom height + 3/4" (19)		<b>Triple</b> Width = transom width - 31.78" (807) Height = transom height - 7.84" (199)

• Dimensions in parentheses are in millimeters.  
 • **"Min. R.O."** (minimum rough opening) formulas provide minimum rough opening width and height dimensions. **"Unobstr. Gls."** (unobstructed glass) formulas provide dimensions for determining area available for passage of light.



## EXTERIOR TRIM

Brick Mould Detail .....	144
3 1/2" & 4 1/2" Flat Casing .....	145
Sill Nose Detail .....	146
Decorative Drip Cap Detail .....	146
2" & 3 5/8" Cornice Details .....	147
Mull Cover Detail .....	147

## FEATURES

### EXTERIOR TRIM

**A** For exceptional long-lasting performance, exterior trim is made from Fibrex® material or high-density urethane with low-maintenance exterior finishes.

**B** Sill nose profile, made from Fibrex material, is available for a traditional look.

**C** Trim is securely fastened to the home using factory-applied or field-applied attachment flange.

**D** Trim surrounds are assembled with corner keys and stainless steel fasteners for stability and strength.



**ANDERSEN**  
INNOVATION

Made of Fibrex material that is an environmentally smart composite, containing 40% pre-consumer reclaimed wood fiber by weight.

ENGINEERED WITH  
**FIBREX**®

### EXTERIOR TRIM COLORS



Design a window or patio door or view exterior trim installation guides at [andersenwindows.com/exteriortrim](http://andersenwindows.com/exteriortrim).

### EXTERIOR TRIM SYSTEM

#### Easier Installation

- Installs independently of water management system
- No nail holes to fill
- No visible fasteners
- No painting

#### Profiles

Exterior trim is available in four profiles made from our Fibrex material. Profiles include 3 1/2" (89) flat casing, 4 1/2" (114) flat casing, 2" (51) brick mould and sill nose for the bottom trim piece.

Thick trim profiles overlap the window frame to create clean lines without visible sealant joints.

#### Drip Cap

A full-length, color-matched aluminum drip cap is included with kits and surrounds.

#### End Caps

Provide a clean appearance when joining two trim members.

#### Corner Keys

Provide tight alignment of corner joints.

#### Fasteners

Screws are made of high-quality stainless steel and provide corner joints with a secure, tight fit.

### Head Trim Options

Three styles are available. All can be used above our flat casing and include an integrated installation flange. The decorative drip cap is made from our Fibrex material. Both the 2" (51) cornice and 3 5/8" (92) cornice are made from highly durable urethane material. See head trim options on the next page.

#### Specialty Trim



Made of highly durable factory-finished urethane material for selected shapes. Contact your Andersen supplier for availability.

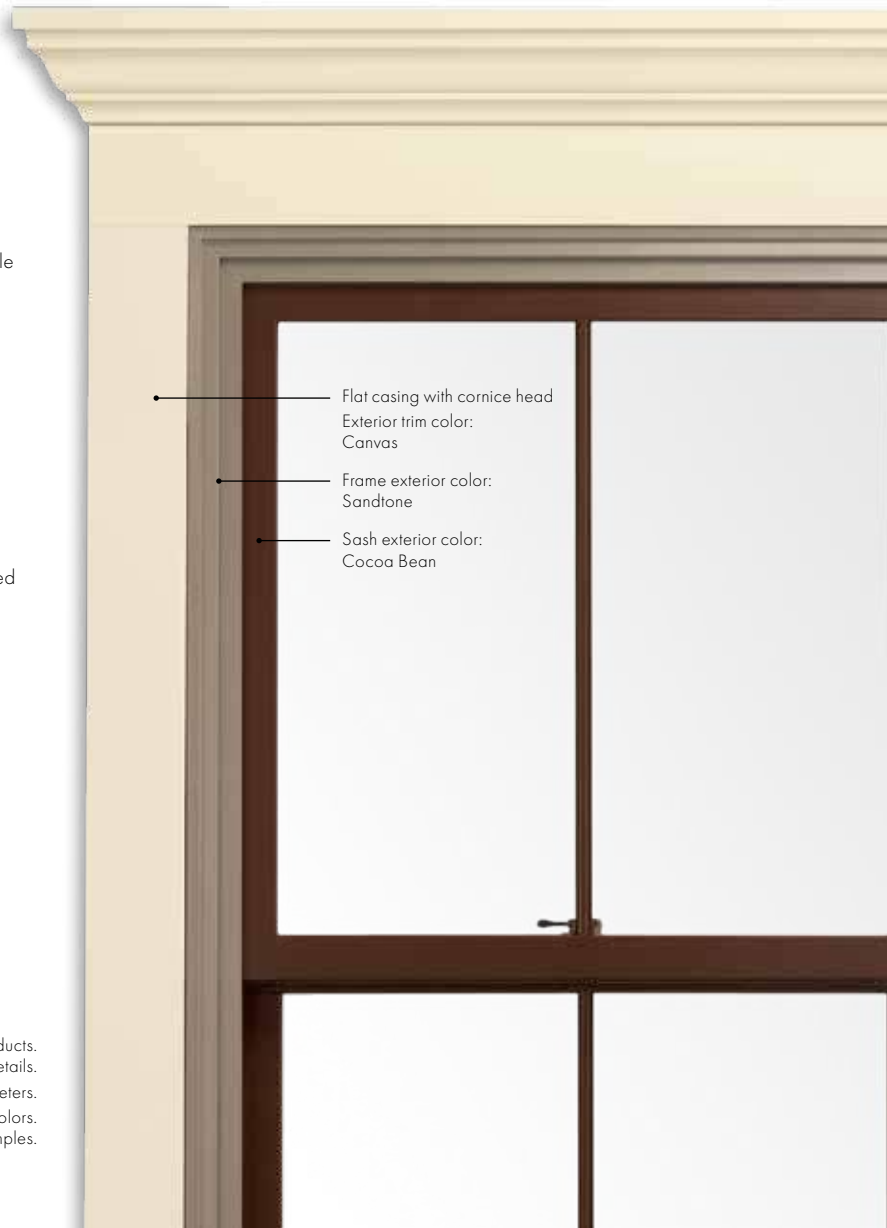

- Flat casing with cornice head  
Exterior trim color:  
Canvas
- Frame exterior color:  
Sandtone
- Sash exterior color:  
Cocoa Bean

\* See the A-Series Limited Warranty for exterior trim applied to A-Series products. Visit [andersenwindows.com/warranty](http://andersenwindows.com/warranty) for details.

Dimensions in parentheses are in millimeters.

Printing limitations prevent exact duplication of colors. See your Andersen supplier for actual color samples.



**INSTALLATION OPTIONS**

**Preassembled Trim Surrounds**

Factory-assembled surrounds install in seconds on A-Series windows with optional factory-applied exterior trim flange.

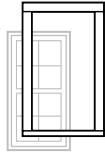

**Precut Kits**

Knock-down kits include precut and predrilled trim with all the necessary components for onsite assembly for windows and patio doors up to 12' (3658) in width or height.

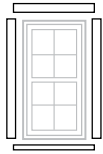

**Individual Trim Components**

13' (3962) factory-finished trim lineals, end caps, corner keys, fasteners, metal drip caps and field attachment strips allow for field fabrication and assembly.

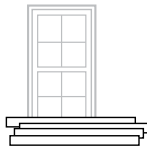

**ACCESSORIES**

**Fibrex® Trim Board**

Andersen offers a 3 1/2" (89) wide by 3/4" (19) thick cellular Fibrex trim board in 10' (3048) lengths. Available in the same 11 colors as the exterior trim system, this solid trim board can be ripped to size and can be fastened using nails or screws.

**Coil Stock**

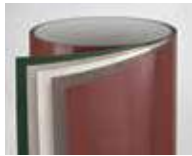

Factory-finished in any of our 11 exterior trim colors, our aluminum coil stock allows you to form your own profiles in the field. Made from .018" thick aluminum, coil stock is available in 24" (610) x 50' (15240) rolls. Color-matched stainless steel trim nails are also available and can be ordered in 1 lb./454 kg boxes.

**PROFILES**



**2" (51) Brick Mould**  
Canvas with Sandtone window



**3 1/2" (89) Flat Casing**  
Shown with extended head in red rock with Sandtone window



**4 1/2" (114) Flat Casing**  
Terratone with Sandtone window

**HEAD TRIM OPTIONS**



**Decorative Drip Cap**  
Shown with 3 1/2" flat casing in forest green with Sandtone window



**2" (51) Cornice**  
Shown with 3 1/2" flat casing in prairie grass with Sandtone window



**3 5/8" (92) Cornice**  
Shown with 3 1/2" flat casing in white with Sandtone window

**SILL OPTIONS**

Mix and match trim to create a variety of combinations. Not all sill options are shown.



**Brick Mould**  
Shown with extended sill nose in Terratone with white window



**3 1/2" (89) or 4 1/2" (114) Flat Casing**  
3 1/2" flat casing shown with extended sill nose in Terratone with red rock window



**3 1/2" (89) or 4 1/2" (114) Flat Casing**  
3 1/2" flat casing shown in white with white window



**3 1/2" (89) or 4 1/2" (114) Flat Casing**  
3 1/2" flat casing shown with in Sandtone with forest green window



**3 1/2" (89) or 4 1/2" (114) Flat Casing**  
3 1/2" flat casing shown with extended 4 1/2" flat casing in white with prairie grass window



**3 1/2" (89) or 4 1/2" (114) Flat Casing**  
3 1/2" flat casing shown with extended sill nose in prairie grass with red rock window

## Window and Patio Door Attachment

### Field-Applied Attachment Strip

Field-applied attachment strip fastens to framing through window or patio door installation flange and flashing tape with screws. Exterior trim connects securely to the field-applied attachment strip. Follow window & patio door installation guides for flashing instructions.

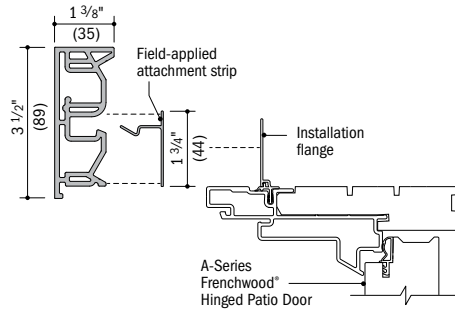

### Factory-Applied Trim Flange

Factory-applied trim flanges are also available. Exterior trim connects securely to the trim flange already in place.

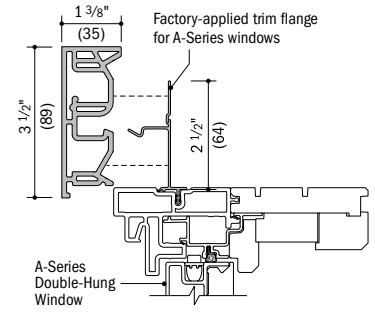

## Brick Mould

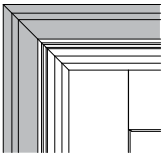

Brick mould with mitered corners

Formula for dimension of window/door plus exterior trim:

**Add 1 3/4" (44) per side for brick mould**

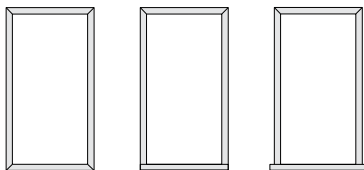
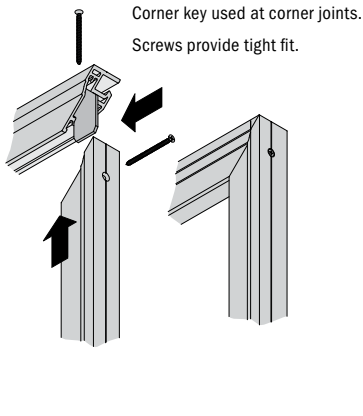

Brick mould can be used on all four sides or with a flush or extended sill nose.

## Trim Details

Scale 3" (76) = 1'-0" (305) – 1:4

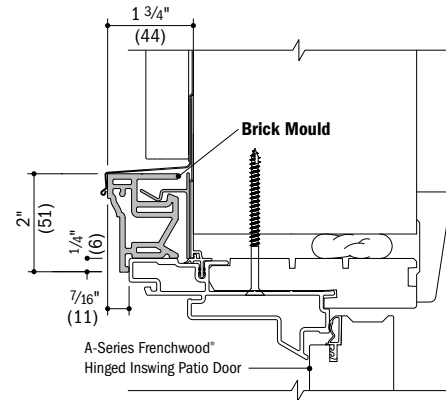

**Vertical Section**  
A-Series Frenchwood® Hinged Inswing Patio Door with Brick Mould

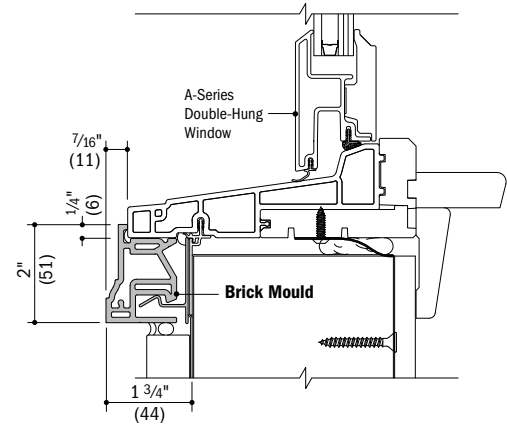

**Vertical Section**  
A-Series Double-Hung Window with Brick Mould

\* Dimensions in parentheses are in millimeters.  
 \* Typical trim combinations shown. Additional combinations may also be used. Some restrictions apply. For more information contact your Andersen supplier.  
 \* Details are for illustration only and are not intended to represent product installation methods or materials. Refer to product installation guides at andersenwindows.com.  
 \* Not all trim options and/or combinations are shown. Contact your Andersen supplier for more information.

**3 1/2" (89) and 4 1/2" (114) Flat Casing**

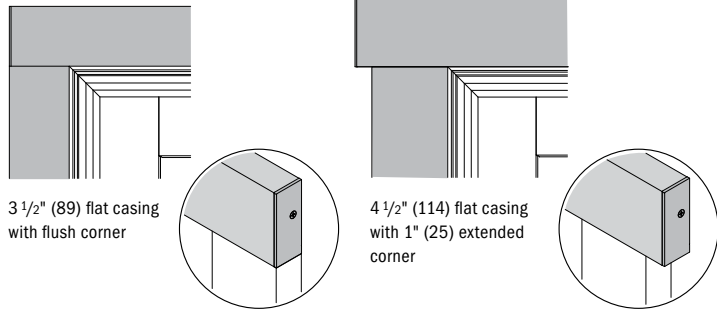

3 1/2" (89) flat casing with flush corner

4 1/2" (114) flat casing with 1" (25) extended corner

Formula for dimension of window/door plus exterior trim:

**Add 4 1/4" (108) per side for 4 1/2" (114) flat casing**

**Add 3 1/4" (83) per side for 3 1/2" (89) flat casing**

End caps are used at corners for flat casing and are handed as viewed from the exterior.

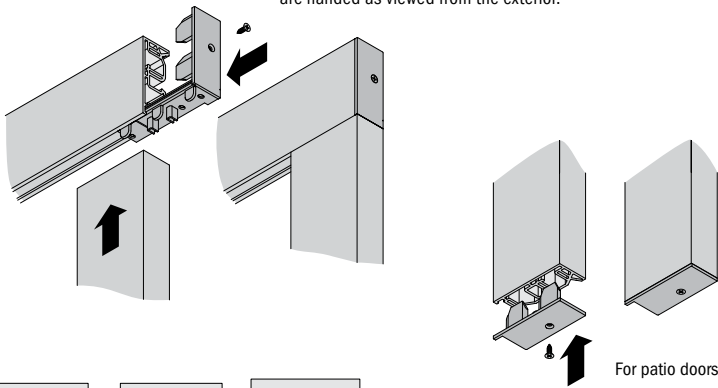

For patio doors, end caps are used at the sill.

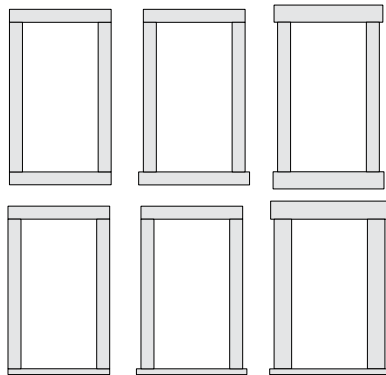

Flat casing can be used on all four sides either flush or extended at the head or sill. Combine 3 1/2" (89) and 4 1/2" (114) flat casing or use with a flush or extended sill nose.

- Dimensions in parentheses are in millimeters.
- Typical trim combinations shown. Additional combinations may also be used. Some restrictions apply. For more information contact your Andersen supplier.
- Details are for illustration only and are not intended to represent product installation methods or materials. Refer to product installation guides at [andersenwindows.com](http://andersenwindows.com).
- Not all trim options and/or combinations are shown. Contact your Andersen supplier for more information.

**Trim Details**

Scale 3" (76) = 1'-0" (305) – 1:4

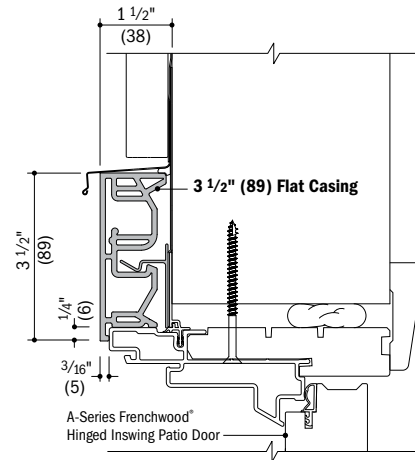

**Vertical Section**

A-Series Frenchwood® Hinged Inswing Patio Door with 3 1/2" (89) Flat Casing

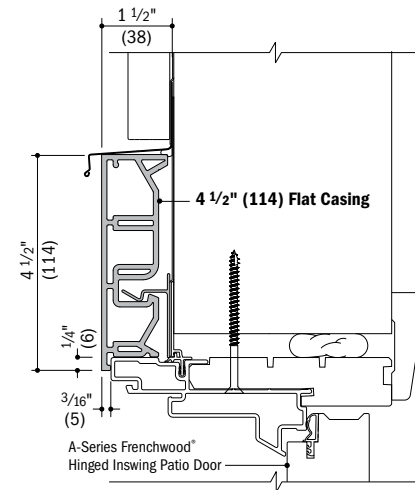

**Vertical Section**

A-Series Frenchwood® Hinged Inswing Patio Door with 4 1/2" (114) Flat Casing

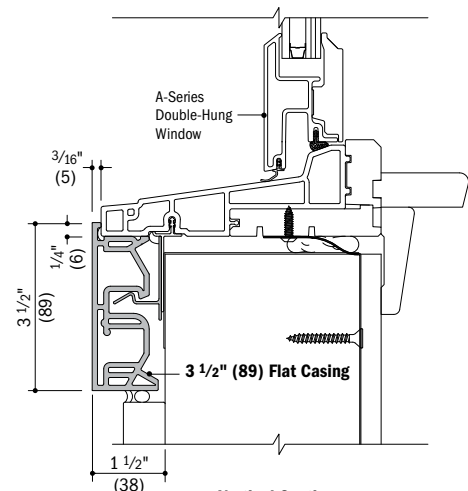

**Vertical Section**

A-Series Double-Hung Window with 3 1/2" (89) Flat Casing

## Sill Nose

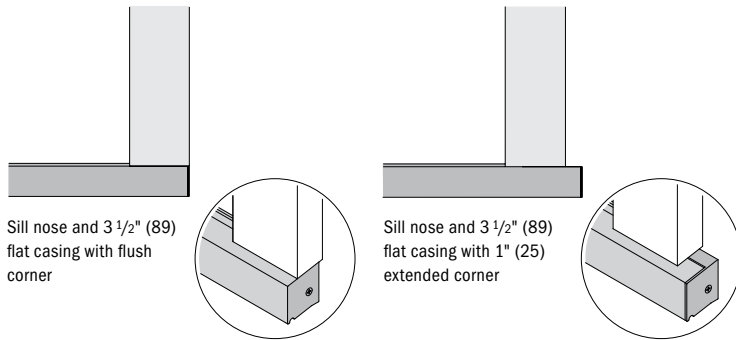

Formula for dimension of window plus exterior trim:  
**Add 1 15/16" (49) for sill nose**

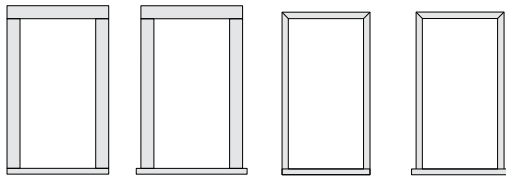

Sill nose can be used with flat casing or brick mould.  
 It can be applied flush or extended at the sill.

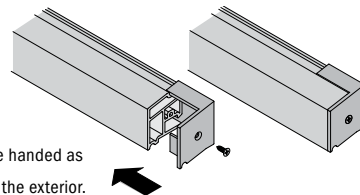

## Trim Detail

Scale 3" (76) = 1'-0" (305) – 1:4

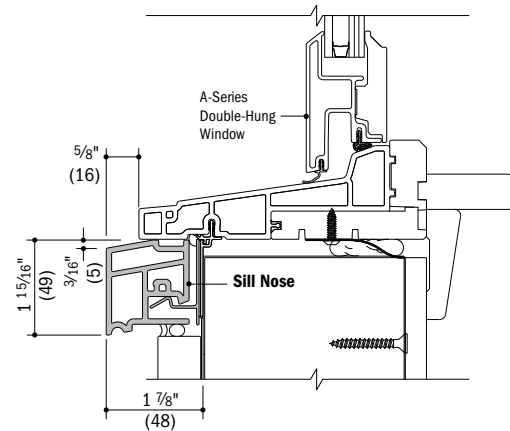

**Vertical Section**  
 A-Series Double-Hung Window with Sill Nose

## Decorative Drip Cap

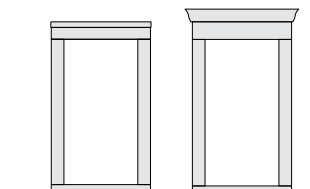
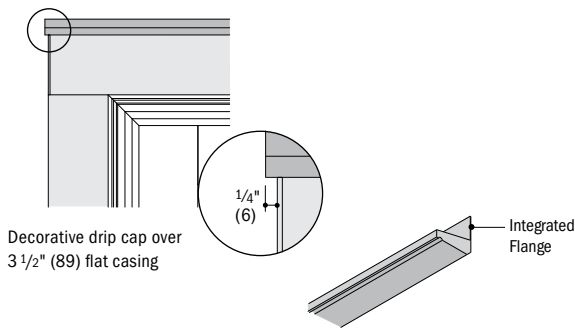

Decorative drip cap or cornices can be used above flat casing at the head.

## Details

Scale 3" (76) = 1'-0" (305) – 1:4

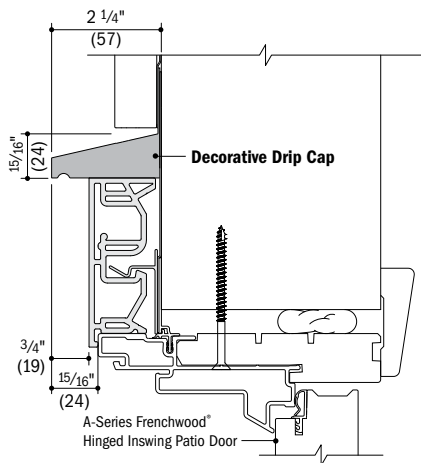

**Vertical Section**  
 A-Series Frenchwood® Hinged Inswing Patio Door with Decorative Drip Cap over 3 1/2" (89) Flat Casing

- Dimensions in parentheses are in millimeters.
- Typical trim combinations shown. Additional combinations may also be used. Some restrictions apply. For more information contact your Andersen supplier.
- Details are for illustration only and are not intended to represent product installation methods or materials. Refer to product installation guides at [andersenwindows.com](http://andersenwindows.com).
- Consult with an architect or structural engineer regarding minimum requirements for structural support members between adjacent rough openings.
- Not all trim options and/or combinations are shown. Contact your Andersen supplier for more information.

**Cornices**

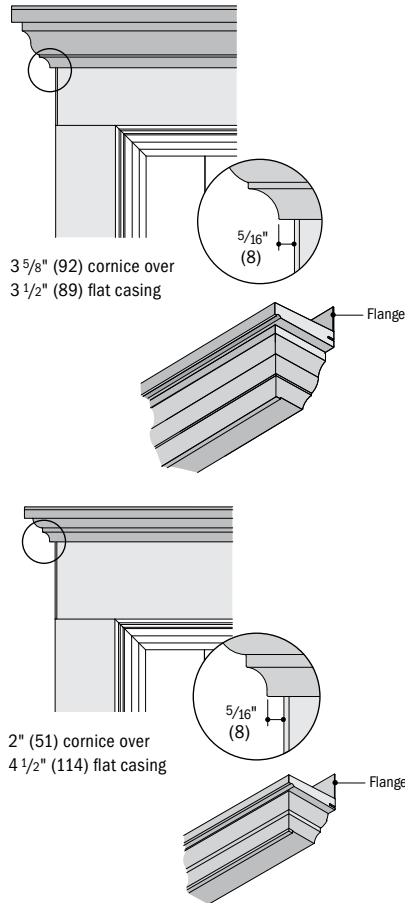

**Details**

Scale 3" (76) = 1'-0" (305) – 1:4

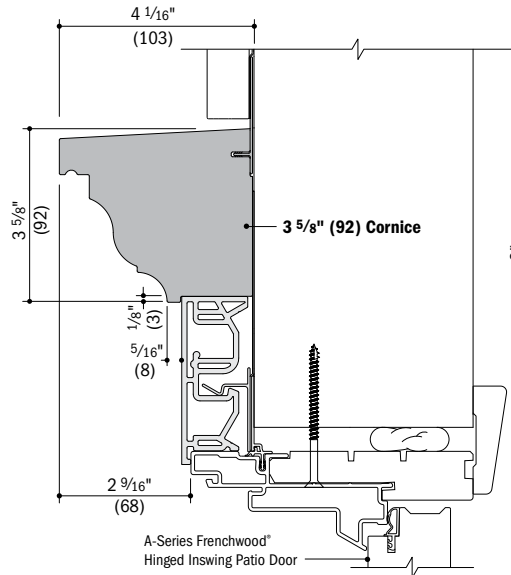

**Vertical Section**  
A-Series Frenchwood® Hinged Inswing Patio Door  
with 3 5/8" (92) Cornice over 3 1/2" (89) Flat Casing

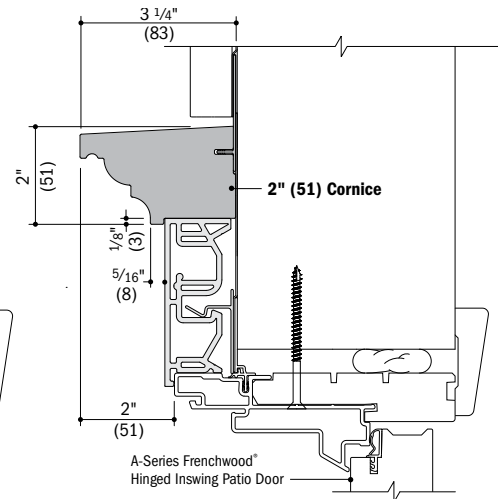

**Vertical Section**  
A-Series Frenchwood® Hinged Inswing Patio Door  
with 2" (51) Cornice over 3 1/2" (89) Flat Casing

**Mull Cover**

3 3/4" (95) mull cover is available for installations where windows or patio doors have been installed into separate rough openings to obtain a joined appearance.

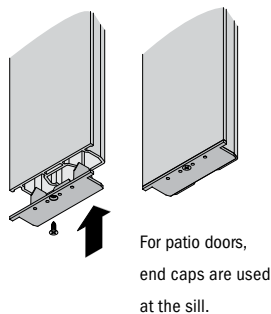

**Separate Rough Opening Detail**

Scale 3" (76) = 1'-0" (305) – 1:4

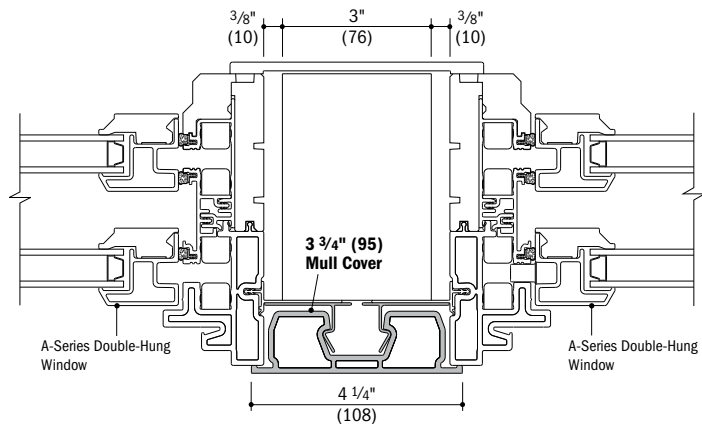

**Horizontal Section**  
A-Series Double-Hung Windows with Mull Cover

- Dimensions in parentheses are in millimeters.
- Typical trim combinations shown. Additional combinations may also be used. Some restrictions apply. For more information contact your Andersen supplier.
- Details are for illustration only and are not intended to represent product installation methods or materials. Refer to product installation guides at [andersenwindows.com](http://andersenwindows.com).
- Consult with an architect or structural engineer regarding minimum requirements for structural support members between adjacent rough openings.

# Andersen® windows and patio doors make it easy to create a wide variety of combination designs

## Combination Types

### Ribbons

Ribbons are horizontal window combinations (vertical joins) where opposite ends (head and sill) of individual windows are fastened to the building structure.

### Stacks

Stacks are vertical window combinations (horizontal joins) where opposite sides (both side jambs) of individual windows are fastened to the building structure.

Two basic configurations are used in combination designs: one-way configurations or two-way configurations.

### 1-Way

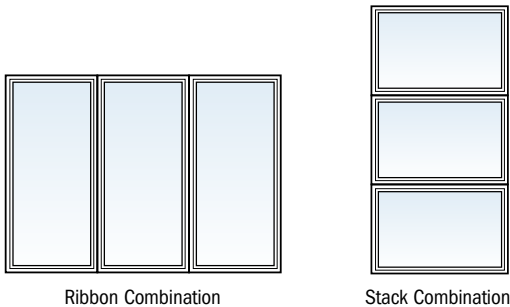

### 2-Way

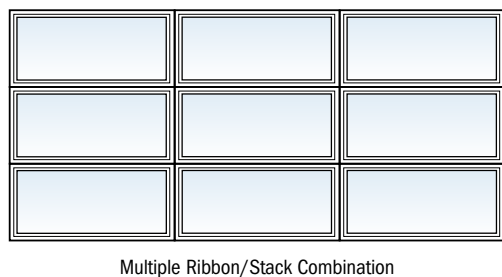

Two-way combinations exist when multiple vertical stacks and horizontal ribbons are joined together. Unlike one-way combinations, the adjacent sides (head and sill, or both side jambs) of individual units are not necessarily fastened directly to the building structure. Two-way combinations are joined with both vertical and horizontal joining material and may require reinforced joining materials and brackets depending on the local building code requirement for design wind load (measured in pounds per square foot, PSF).

## Determining Design Wind Load Performance

Proper combination design in conformance with local wind load requirements is vital to the success of your project. To make sure a combination is safe and that it complies with local building codes, the combination design wind load performance capacity must be determined.

Correctly determining this performance capacity involves the following three steps:

### STEP 1

#### Determine Building Code Requirement

Make sure that you have the proper local codes and have identified specified compliance values. This calculated value (PSF) will be used to determine if the combination will be acceptable (STEP 3).



### STEP 2

#### Determine Product Performance

Compare product Design Pressure Rating data to the local building code (PSF) requirement. This will show whether the individual units in a combination design are acceptable.



### STEP 3

#### Determine Combination Performance

This step helps determine whether a given product, size, configuration and joining material type will meet the local building code design wind load requirement. Compare the local building code design wind load requirement to the design wind load table value for the joining materials on the following pages.

## Andersen® Joining Materials

For a successful installation, one engineered to provide the required design pressure, it is important for Andersen joining materials and installation accessories be specified by a project architect or contractor. For one-way and two-way combinations, Andersen offers a fiberglass joining system to meet specified performance requirements. For factory-joined specialty-to-specialty window combinations, a Laminated Veneer Lumber (LVL) joining material is used. Both joining systems enhance the look of Andersen products without sacrificing performance.

The addition of joining materials will affect the overall rough opening dimension, see page 170. **For all joining methods, see instruction guides for specific joining and anchoring information. Instruction guides are available at [andersenwindows.com](http://andersenwindows.com). Read and follow instruction guides in their entirety.\***

Exterior trim strips and trim strip end caps are included with each kit for finishing exterior join. Interior casing is included with each joining kit for finishing the join on the interior.

## Reinforced Joining Material

Reinforced joining material is used to create product alignment, positive joining and load transfer between the rough opening and Andersen A-Series windows and doors. Joining materials provide added strength capable of withstanding a greater range of wind load pressures.

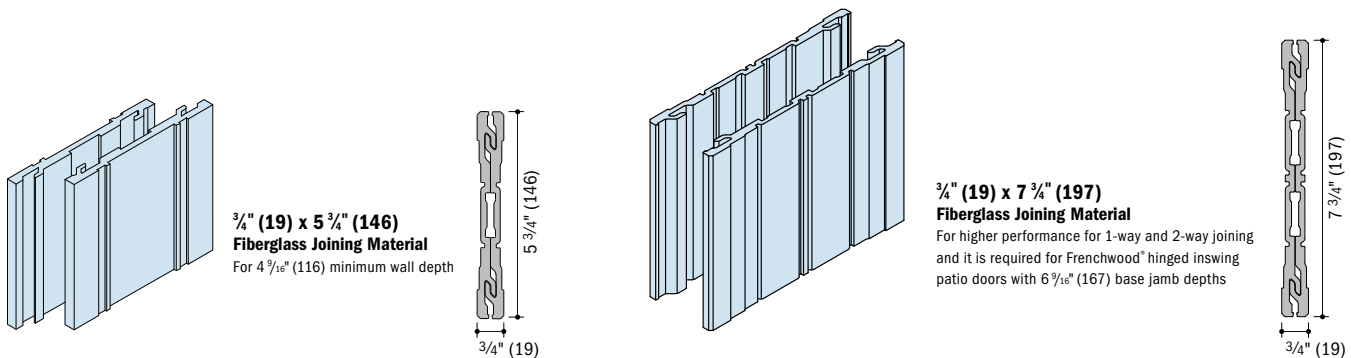

**Fiberglass Joining System** for A-Series windows\*\* and patio doors utilizes either  $\frac{3}{4}$ " (19) x  $5\frac{3}{4}$ " (146) fiberglass interlocking joining plates for  $4\frac{9}{16}$ " (116) minimum wall depth or  $\frac{3}{4}$ " (19) x  $7\frac{3}{4}$ " (197) fiberglass interlocking joining plates for higher performance for one-way and two-way joining and is required for Frenchwood® hinged inswing patio doors with  $6\frac{9}{16}$ " (167) base jamb depths. For windows, three variations are available. The Easy Connect Joining System makes installation at the jobsite easier with smaller, factory-assembled sub-group combinations that join together as they are installed in the rough opening. The innovative design eliminates the need to disassemble units prior to joining and provides higher performance. Fully joined combinations are factory assembled and arrive ready for installation in sizes up to 12' (3658) x 8' (2438) or 8' (2438) x 12' (3658). Fiberglass reinforced joining kits include the necessary joining materials for individual units to be joined at the jobsite. For A-Series patio doors, fiberglass reinforced joining kits are provided for joining and installing patio door, sidelight and/or transom combinations at the jobsite. Extension jambs are available factory-applied for factory-joined combinations. Extension jamb kits are available for field-joined combinations. In some situations, joining material may prohibit the application of perimeter extension jambs. For more information on fiberglass material joining, see page 18 or contact your Andersen supplier. For more information and to view an Easy Connect Joining System video, visit [andersenwindow.com/joining](http://andersenwindow.com/joining).

**Laminated Veneer Lumber (LVL)** joining materials with aluminum exterior trim receiver are used for factory-joined specialty-to-specialty window combinations only. Available for both  $4\frac{9}{16}$ " (116) and  $6\frac{9}{16}$ " (167) minimum wall depths in lengths up to 10'-4" (3150).

\* Dimensions in parentheses are in millimeters.

\*\* See Florida Product Approval documents for additional details on structural joining and performance ratings.

\*Andersen® products must be installed and anchored properly according to joining and installation guides to meet rated structural performance.

\*\*For factory-joined specialty-to-specialty window combinations, LVL joining material will be used.

**1-Way Fiberglass Joining**

A-Series: Casement, Awning, Double-Hung, Picture, Transom, Specialty Windows\*

<b>4 9/16" (116)</b> Minimum Wall Depth	(A + B) ÷ 2 = <b>12'-0"</b> (3658)	70	70	70	70	70	70	70	70	70	70	66	58	50
	(A + B) ÷ 2 = <b>11'-6"</b> (3505)	70	70	70	70	70	70	70	70	70	70	66	58	50
	(A + B) ÷ 2 = <b>11'-0"</b> (3353)	70	70	70	70	70	70	70	70	70	70	66	58	50
	(A + B) ÷ 2 = <b>10'-6"</b> (3200)	70	70	70	70	70	70	70	70	70	70	66	58	50
	(A + B) ÷ 2 = <b>10'-0"</b> (3048)	70	70	70	70	70	70	70	70	70	70	66	58	50
	(A + B) ÷ 2 = <b>9'-6"</b> (2896)	70	70	70	70	70	70	70	70	70	70	66	58	50
	(A + B) ÷ 2 = <b>9'-0"</b> (2743)	70	70	70	70	70	70	70	70	70	70	66	58	50
	(A + B) ÷ 2 = <b>8'-6"</b> (2591)	70	70	70	70	70	70	70	70	70	70	66	58	50
	(A + B) ÷ 2 = <b>8'-0"</b> (2438)	70	70	70	70	70	70	70	70	70	70	66	58	50
	(A + B) ÷ 2 = <b>7'-6"</b> (2286)	70	70	70	70	70	70	70	70	70	70	66	58	50
	(A + B) ÷ 2 = <b>7'-0"</b> (2134)	70	70	70	70	70	70	70	70	70	70	66	58	51
	(A + B) ÷ 2 = <b>6'-6"</b> (1981)	70	70	70	70	70	70	70	70	70	70	67	59	52
	(A + B) ÷ 2 = <b>6'-0"</b> (1829)	70	70	70	70	70	70	70	70	70	70	68	60	54
	(A + B) ÷ 2 = <b>5'-6"</b> (1676)	70	70	70	70	70	70	70	70	70	70	69	62	56
	(A + B) ÷ 2 = <b>5'-0"</b> (1524)	70	70	70	70	70	70	70	70	70	70	70	65	59
	(A + B) ÷ 2 = <b>4'-6"</b> (1372)	70	70	70	70	70	70	70	70	70	70	70	69	63
	(A + B) ÷ 2 = <b>4'-0"</b> (1219)	70	70	70	70	70	70	70	70	70	70	70	70	68
	(A + B) ÷ 2 = <b>3'-6"</b> (1067)	70	70	70	70	70	70	70	70	70	70	70	70	70
	(A + B) ÷ 2 = <b>3'-0"</b> (914)	70	70	70	70	70	70	70	70	70	70	70	70	70
	(A + B) ÷ 2 = <b>2'-6"</b> (762)	70	70	70	70	70	70	70	70	70	70	70	70	70
(A + B) ÷ 2 = <b>2'-0"</b> (610)	70	70	70	70	70	70	70	70	70	70	70	70	70	
(A + B) ÷ 2 = <b>1'-6"</b> (457)	70	70	70	70	70	70	70	70	70	70	70	70	70	
<b>C = (length of join)</b>	<b>2'-0"</b> (610)	<b>2'-6"</b> (762)	<b>3'-0"</b> (914)	<b>3'-6"</b> (1067)	<b>4'-0"</b> (1219)	<b>4'-6"</b> (1372)	<b>5'-0"</b> (1524)	<b>5'-6"</b> (1676)	<b>6'-0"</b> (1829)	<b>6'-6"</b> (1981)	<b>7'-0"</b> (2134)	<b>7'-6"</b> (2286)	<b>8'-0"</b> (2438)	

continued on next page

**2-Way Fiberglass Joining**

A-Series: Casement, Awning, Double-Hung, Picture, Transom, Specialty Windows\*

<b>4 9/16" (116)</b> Minimum Wall Depth	(A + B) ÷ 2 = <b>12'-0"</b> (3658)	70	70	69	59	52	46	41	36	30	25	22		
	(A + B) ÷ 2 = <b>11'-6"</b> (3505)	70	70	70	62	54	48	43	38	32	27	23	20	
	(A + B) ÷ 2 = <b>11'-0"</b> (3048)	70	70	70	65	57	50	47	39	33	28	23	21	
	(A + B) ÷ 2 = <b>10'-6"</b> (3200)	70	70	70	68	59	53	50	41	35	29	24	22	
	(A + B) ÷ 2 = <b>10'-0"</b> (3048)	70	70	70	70	62	55	52	43	36	31	25	23	20
	(A + B) ÷ 2 = <b>9'-6"</b> (2896)	70	70	70	70	66	58	55	46	38	33	27	24	21
	(A + B) ÷ 2 = <b>9'-0"</b> (2743)	70	70	70	70	69	62	59	48	40	34	28	26	23
	(A + B) ÷ 2 = <b>8'-6"</b> (2591)	70	70	70	70	70	65	62	51	43	36	30	27	24
	(A + B) ÷ 2 = <b>8'-0"</b> (2438)	70	70	70	70	70	69	67	54	45	39	31	29	25
	(A + B) ÷ 2 = <b>7'-6"</b> (2286)	70	70	70	70	70	70	70	56	49	41	33	31	27
	(A + B) ÷ 2 = <b>7'-0"</b> (2134)	70	70	70	70	70	70	70	62	52	44	36	33	29
	(A + B) ÷ 2 = <b>6'-6"</b> (1981)	70	70	70	70	70	70	70	67	58	48	38	36	31
	(A + B) ÷ 2 = <b>6'-0"</b> (1829)	70	70	70	70	70	70	70	70	61	52	41	38	34
	(A + B) ÷ 2 = <b>5'-6"</b> (1676)	70	70	70	70	70	70	70	70	66	58	45	42	37
	(A + B) ÷ 2 = <b>5'-0"</b> (1524)	70	70	70	70	70	70	70	70	70	62	49	47	41
	(A + B) ÷ 2 = <b>4'-6"</b> (1372)	70	70	70	70	70	70	70	70	70	69	54	52	45
	(A + B) ÷ 2 = <b>4'-0"</b> (1219)	70	70	70	70	70	70	70	70	70	62	60	58	51
	(A + B) ÷ 2 = <b>3'-6"</b> (1067)	70	70	70	70	70	70	70	70	70	70	67	67	59
	(A + B) ÷ 2 = <b>3'-0"</b> (914)	70	70	70	70	70	70	70	70	70	70	70	70	68
	(A + B) ÷ 2 = <b>2'-6"</b> (762)	70	70	70	70	70	70	70	70	70	70	70	70	70
(A + B) ÷ 2 = <b>2'-0"</b> (610)	70	70	70	70	70	70	70	70	70	70	70	70	70	
(A + B) ÷ 2 = <b>1'-6"</b> (457)	70	70	70	70	70	70	70	70	70	70	70	70	70	
<b>C = (length of join)</b>	<b>2'-0"</b> (610)	<b>2'-6"</b> (762)	<b>3'-0"</b> (914)	<b>3'-6"</b> (1067)	<b>4'-0"</b> (1219)	<b>4'-6"</b> (1372)	<b>5'-0"</b> (1524)	<b>5'-6"</b> (1676)	<b>6'-0"</b> (1829)	<b>6'-6"</b> (1981)	<b>7'-0"</b> (2134)	<b>7'-6"</b> (2286)	<b>8'-0"</b> (2438)	

\* Numeric value represents the certified Performance Grade (PG) rating of the combination.

\* Structural performance of any combination is only as high as the lowest structural performance of any individual unit or joining material in the combination.

\* Andersen® products must be installed and anchored properly according to joining and installation guides to meet rated structural performance. Refer to product joining and installation guides at andersenwindows.com.

\* Dimensions in parentheses are in millimeters.

\* See Florida Product Approval documents for additional details on structural joining and performance ratings.

\* For factory-joined specialty-to-specialty window combinations, LVL joining material will be used. See charts on pages 154-155.

continued on next page



1-Way Fiberglass Joining continued from previous page

42	35	30	24	20			
42	35	30	24	20			
42	35	30	24	20			
42	35	30	24	20			
42	35	30	24	20			
42	35	30	24	20			
42	35	30	25	21			
42	35	30	25	21			
42	36	31	26	22			
43	37	32	26	22			
44	38	33	27	23	20		
45	39	34	30	24	21		
47	41	36	31	26	22		
50	44	39	33	28	24	20	
54	47	42	36	31	26	22	
58	51	46	39	34	28	24	21
62	57	50	43	37	32	27	24
69	64	57	49	42	36	32	27
70	70	66	56	48	42	37	32
70	70	70	67	58	50	44	38
70	70	70	70	70	62	54	48
70	70	70	70	70	70	70	63
<b>8'-6"</b> (2591)	<b>9'-0"</b> (2743)	<b>9'-6"</b> (2896)	<b>10'-0"</b> (3048)	<b>10'-6"</b> (3200)	<b>11'-0"</b> (3353)	<b>11'-6"</b> (3505)	<b>12'-0"</b> (3658)

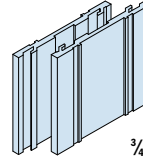
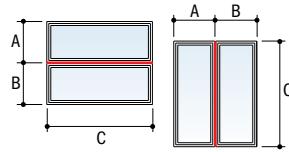

**3/4" (19) x 5 3/4" (146)**  
**Fiberglass Joining Material**  
For 4 7/16" (116) minimum wall depth

2-Way Fiberglass Joining continued from previous page

20							
21							
22	20						
24	21						
26	23	20					
28	25	22	20				
30	27	24	22	20			
32	29	26	24	21			
35	32	29	26	24	21	20	
39	35	31	29	26	24	22	20
44	40	35	32	30	27	25	23
51	45	41	37	33	30	28	26
59	53	47	43	39	35	32	30
70	64	57	51	47	42	39	36
70	70	70	64	58	53	49	45
70	70	70	70	70	70	65	60
<b>8'-6"</b> (2591)	<b>9'-0"</b> (2743)	<b>9'-6"</b> (2896)	<b>10'-0"</b> (3048)	<b>10'-6"</b> (3200)	<b>11'-0"</b> (3353)	<b>11'-6"</b> (3505)	<b>12'-0"</b> (3658)

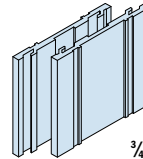
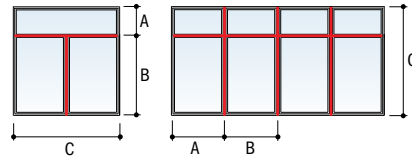

**3/4" (19) x 5 3/4" (146)**  
**Fiberglass Joining Material**  
For 4 7/16" (116) minimum wall depth

- \* Numeric value represents the certified Performance Grade (PG) rating of the combination.
- \* Structural performance of any combination is only as high as the lowest structural performance of any individual unit or joining material in the combination.
- \* Andersen® products must be installed and anchored properly according to joining and installation guides to meet rated structural performance. Refer to product joining and installation guides at andersenwindows.com.
- \* Dimensions in parentheses are in millimeters.
- \* See Florida Product Approval documents for additional details on structural joining and performance ratings.
- \* For factory-joined specialty-to-specialty window combinations, LVL joining material will be used. See charts on pages 154-155.

**1-Way Fiberglass Joining\***

A-Series: Casement, Awning, Double-Hung, Picture, Transom, Specialty Windows\*\*

<b>6 9/16" (167)</b> Minimum Wall Depth	(A + B) ÷ 2 = <b>12'-0"</b> (3658)	70	70	70	70	70	70	70	70	70	70	70	70	70
	(A + B) ÷ 2 = <b>11'-6"</b> (3505)	70	70	70	70	70	70	70	70	70	70	70	70	70
	(A + B) ÷ 2 = <b>11'-0"</b> (3353)	70	70	70	70	70	70	70	70	70	70	70	70	70
	(A + B) ÷ 2 = <b>10'-6"</b> (3200)	70	70	70	70	70	70	70	70	70	70	70	70	70
	(A + B) ÷ 2 = <b>10'-0"</b> (3048)	70	70	70	70	70	70	70	70	70	70	70	70	70
	(A + B) ÷ 2 = <b>9'-6"</b> (2896)	70	70	70	70	70	70	70	70	70	70	70	70	70
	(A + B) ÷ 2 = <b>9'-0"</b> (2743)	70	70	70	70	70	70	70	70	70	70	70	70	70
	(A + B) ÷ 2 = <b>8'-6"</b> (2591)	70	70	70	70	70	70	70	70	70	70	70	70	70
	(A + B) ÷ 2 = <b>8'-0"</b> (2438)	70	70	70	70	70	70	70	70	70	70	70	70	70
	(A + B) ÷ 2 = <b>7'-6"</b> (2286)	70	70	70	70	70	70	70	70	70	70	70	70	70
	(A + B) ÷ 2 = <b>7'-0"</b> (2134)	70	70	70	70	70	70	70	70	70	70	70	70	70
	(A + B) ÷ 2 = <b>6'-6"</b> (1981)	70	70	70	70	70	70	70	70	70	70	70	70	70
	(A + B) ÷ 2 = <b>6'-0"</b> (1829)	70	70	70	70	70	70	70	70	70	70	70	70	70
	(A + B) ÷ 2 = <b>5'-6"</b> (1676)	70	70	70	70	70	70	70	70	70	70	70	70	70
	(A + B) ÷ 2 = <b>5'-0"</b> (1524)	70	70	70	70	70	70	70	70	70	70	70	70	70
	(A + B) ÷ 2 = <b>4'-6"</b> (1372)	70	70	70	70	70	70	70	70	70	70	70	70	70
	(A + B) ÷ 2 = <b>4'-0"</b> (1219)	70	70	70	70	70	70	70	70	70	70	70	70	70
	(A + B) ÷ 2 = <b>3'-6"</b> (1067)	70	70	70	70	70	70	70	70	70	70	70	70	70
	(A + B) ÷ 2 = <b>3'-0"</b> (914)	70	70	70	70	70	70	70	70	70	70	70	70	70
	(A + B) ÷ 2 = <b>2'-6"</b> (762)	70	70	70	70	70	70	70	70	70	70	70	70	70
(A + B) ÷ 2 = <b>2'-0"</b> (610)	70	70	70	70	70	70	70	70	70	70	70	70	70	
(A + B) ÷ 2 = <b>1'-6"</b> (457)	70	70	70	70	70	70	70	70	70	70	70	70	70	
<b>C = (length of join)</b>	<b>2'-0"</b> (610)	<b>2'-6"</b> (762)	<b>3'-0"</b> (914)	<b>3'-6"</b> (1067)	<b>4'-0"</b> (1219)	<b>4'-6"</b> (1372)	<b>5'-0"</b> (1524)	<b>5'-6"</b> (1676)	<b>6'-0"</b> (1829)	<b>6'-6"</b> (1981)	<b>7'-0"</b> (2134)	<b>7'-6"</b> (2286)	<b>8'-0"</b> (2438)	

continued on next page

**2-Way Fiberglass Joining\***

A-Series: Casement, Awning, Double-Hung, Picture, Transom, Specialty Windows\*\*

<b>6 9/16" (167)</b> Minimum Wall Depth	(A + B) ÷ 2 = <b>12'-0"</b> (3658)	70	70	70	70	62	55	50	45	41	38	35	33	31
	(A + B) ÷ 2 = <b>11'-6"</b> (3505)	70	70	70	70	65	58	52	47	43	40	37	34	32
	(A + B) ÷ 2 = <b>11'-0"</b> (3048)	70	70	70	70	60	54	49	45	42	39	36	34	32
	(A + B) ÷ 2 = <b>10'-6"</b> (3200)	70	70	70	70	63	57	51	47	44	40	38	35	33
	(A + B) ÷ 2 = <b>10'-0"</b> (3048)	70	70	70	70	70	66	60	54	50	48	42	40	37
	(A + B) ÷ 2 = <b>9'-6"</b> (2896)	70	70	70	70	70	70	63	57	52	48	45	42	39
	(A + B) ÷ 2 = <b>9'-0"</b> (2743)	70	70	70	70	70	70	66	60	55	51	47	44	41
	(A + B) ÷ 2 = <b>8'-6"</b> (2591)	70	70	70	70	70	70	70	64	58	54	50	47	44
	(A + B) ÷ 2 = <b>8'-0"</b> (2438)	70	70	70	70	70	70	70	68	62	57	53	50	46
	(A + B) ÷ 2 = <b>7'-6"</b> (2286)	70	70	70	70	70	70	70	70	66	61	57	53	50
	(A + B) ÷ 2 = <b>7'-0"</b> (2134)	70	70	70	70	70	70	70	70	70	65	61	57	53
	(A + B) ÷ 2 = <b>6'-6"</b> (1981)	70	70	70	70	70	70	70	70	70	65	61	57	54
	(A + B) ÷ 2 = <b>6'-0"</b> (1829)	70	70	70	70	70	70	70	70	70	70	70	66	62
	(A + B) ÷ 2 = <b>5'-6"</b> (1676)	70	70	70	70	70	70	70	70	70	70	70	70	68
	(A + B) ÷ 2 = <b>5'-0"</b> (1524)	70	70	70	70	70	70	70	70	70	70	70	70	70
	(A + B) ÷ 2 = <b>4'-6"</b> (1372)	70	70	70	70	70	70	70	70	70	70	70	70	70
	(A + B) ÷ 2 = <b>4'-0"</b> (1219)	70	70	70	70	70	70	70	70	70	70	70	70	70
	(A + B) ÷ 2 = <b>3'-6"</b> (1067)	70	70	70	70	70	70	70	70	70	70	70	70	70
	(A + B) ÷ 2 = <b>3'-0"</b> (914)	70	70	70	70	70	70	70	70	70	70	70	70	70
	(A + B) ÷ 2 = <b>2'-6"</b> (762)	70	70	70	70	70	70	70	70	70	70	70	70	70
(A + B) ÷ 2 = <b>2'-0"</b> (610)	70	70	70	70	70	70	70	70	70	70	70	70	70	
(A + B) ÷ 2 = <b>1'-6"</b> (457)	70	70	70	70	70	70	70	70	70	70	70	70	70	
<b>C = (length of join)</b>	<b>2'-0"</b> (610)	<b>2'-6"</b> (762)	<b>3'-0"</b> (914)	<b>3'-6"</b> (1067)	<b>4'-0"</b> (1219)	<b>4'-6"</b> (1372)	<b>5'-0"</b> (1524)	<b>5'-6"</b> (1676)	<b>6'-0"</b> (1829)	<b>6'-6"</b> (1981)	<b>7'-0"</b> (2134)	<b>7'-6"</b> (2286)	<b>8'-0"</b> (2438)	

\* Numeric value represents the certified Performance Grade (PG) rating of the combination.

\* Structural performance of any combination is only as high as the lowest structural performance of any individual unit or joining material in the combination.

\* Andersen® products must be installed and anchored properly according to joining and installation guides to meet rated structural performance. Refer to product joining and installation guides at andersenwindows.com.

\* Dimensions in parentheses are in millimeters.

\* See Florida Product Approval documents for additional details on structural joining and performance ratings.

\* 7 3/8" fiberglass joining material components for joining windows are available field applied only. Half gusset plates and end plugs must be ordered separately. Contact your Andersen supplier for more information.

\*\*For factory-joined specialty-to-specialty window combinations, LVL joining material will be used. See charts on pages 154-155.

continued on next page

1-Way Fiberglass Joining continued from previous page

70	70	66	57	47	39	32	27	23	20		
70	70	66	57	47	39	32	27	23	20		
70	70	66	57	47	39	32	27	23	20		
70	70	66	57	47	39	33	28	24	21		
70	70	66	57	47	39	33	28	24	21		
70	70	66	57	47	40	34	29	25	22		
70	70	66	58	48	40	34	29	25	22		
70	65	58	53	49	41	35	31	26	23	20	
70	70	66	60	50	43	36	31	27	24	21	
70	70	69	62	52	44	38	33	29	25	22	20
70	70	70	64	54	46	40	34	30	26	23	21
70	70	70	67	57	48	42	36	32	28	25	22
70	70	70	70	60	51	44	39	34	30	26	24
70	70	70	70	64	55	48	42	36	32	29	25
70	70	70	70	65	59	52	45	40	35	31	28
70	70	70	70	70	65	57	49	44	38	34	30
70	70	70	70	70	70	63	55	48	43	38	34
70	70	70	70	70	70	70	62	55	49	43	39
70	70	70	70	70	70	70	70	64	56	50	45
70	70	70	70	70	70	70	70	70	67	60	54
70	70	70	70	70	70	70	70	70	70	67	67
70	70	70	70	70	70	70	70	70	70	70	70
<b>8'-6"</b> (2591)	<b>9'-0"</b> (2743)	<b>9'-6"</b> (2896)	<b>10'-0"</b> (3048)	<b>10'-6"</b> (3200)	<b>11'-0"</b> (3353)	<b>11'-6"</b> (3505)	<b>12'-0"</b> (3658)	<b>12'-6"</b> (3810)	<b>13'-0"</b> (3962)	<b>13'-6"</b> (4115)	<b>14'-0"</b> (4267)

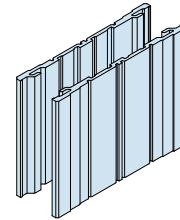
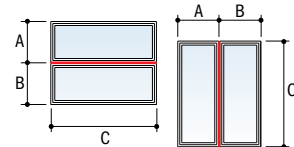

**3/4" (19) x 7 3/4" (197)**

**Fiberglass Joining Material\***

For higher performance for 1-way and 2-way joining and it is required for Frenchwood® hinged inswing patio doors with 6 3/16" (167) base jamb depths

2-Way Fiberglass Joining continued from previous page

29	27	26	25	22	20						
30	29	27	26	23	21						
30	28	27	25	22	20						
31	30	28	26	23	21	20					
35	33	31	30	27	25	22	21				
37	35	33	31	28	26	24	22	20			
39	37	35	33	30	27	25	23	21			
41	39	37	35	32	29	27	24	22	21		
44	41	39	37	34	31	28	26	24	22	20	
47	44	42	40	36	33	30	28	25	23	22	20
50	47	45	42	39	35	32	30	27	25	23	22
51	48	46	42	38	35	33	32	29	27	25	23
58	55	52	50	45	41	38	35	32	29	27	25
64	60	57	54	50	45	41	38	35	32	30	28
70	66	63	60	55	50	45	42	38	35	33	30
70	70	70	66	61	55	50	46	43	39	37	34
70	70	70	70	68	62	57	52	48	44	41	38
70	70	70	70	70	70	65	60	55	51	47	44
70	70	70	70	70	70	70	70	64	59	55	51
70	70	70	70	70	70	70	70	70	70	66	61
70	70	70	70	70	70	70	70	70	70	70	70
70	70	70	70	70	70	70	70	70	70	70	70
<b>8'-6"</b> (2591)	<b>9'-0"</b> (2743)	<b>9'-6"</b> (2896)	<b>10'-0"</b> (3048)	<b>10'-6"</b> (3200)	<b>11'-0"</b> (3353)	<b>11'-6"</b> (3505)	<b>12'-0"</b> (3658)	<b>12'-6"</b> (3810)	<b>13'-0"</b> (3962)	<b>13'-6"</b> (4115)	<b>14'-0"</b> (4267)

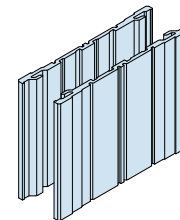
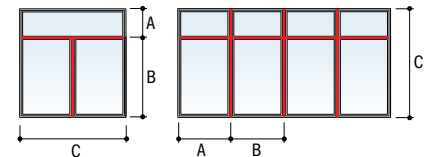

**3/4" (19) x 7 3/4" (197)**

**Fiberglass Joining Material\***

For higher performance for 1-way and 2-way joining and it is required for Frenchwood® hinged inswing patio doors with 6 3/16" (167) base jamb depths

\* Numeric value represents the certified Performance Grade (PG) rating of the combination.

\* Structural performance of any combination is only as high as the lowest structural performance of any individual unit or joining material in the combination.

\* Andersen® products must be installed and anchored properly according to joining and installation guides to meet rated structural performance. Refer to product joining and installation guides at andersenwindows.com.

\* Dimensions in parentheses are in millimeters.

\* See Florida Product Approval documents for additional details on structural joining and performance ratings.

\* 7/8" fiberglass joining material components for joining windows are available field applied only. Half gusset plates and end plugs must be ordered separately. Contact your Andersen supplier for more information.

\*\*For factory-joined specialty-to-specialty window combinations, LVL joining material will be used. See charts on pages 154-155.

## 1-Way LVL Joining

### A-Series: Factory-Joined Specialty-to-Specialty Windows

<b>4 9/16" (116)</b> Minimum Wall Depth	Average Adjacent Window Dimension	(A + B) ÷ 2 = <b>10'-0"</b> (3048)	70	70	70	55	44	33															
		(A + B) ÷ 2 = <b>9'-6"</b> (2896)	70	70	70	55	44	33															
		(A + B) ÷ 2 = <b>9'-0"</b> (2743)	70	70	70	55	44	33															
		(A + B) ÷ 2 = <b>8'-6"</b> (2591)	70	70	70	55	44	33															
		(A + B) ÷ 2 = <b>8'-0"</b> (2438)	70	70	70	55	44	33															
		(A + B) ÷ 2 = <b>7'-6"</b> (2286)	70	70	70	55	44	33															
		(A + B) ÷ 2 = <b>7'-0"</b> (2134)	70	70	70	55	44	33															
		(A + B) ÷ 2 = <b>6'-6"</b> (1981)	70	70	70	56	45	34															
		(A + B) ÷ 2 = <b>6'-0"</b> (1829)	70	70	70	56	45	35															
		(A + B) ÷ 2 = <b>5'-6"</b> (1676)	70	70	70	58	47	36	30														
		(A + B) ÷ 2 = <b>5'-0"</b> (1524)	70	70	70	60	49	38	32														
		(A + B) ÷ 2 = <b>4'-6"</b> (1372)	70	70	70	64	52	40	34														
		(A + B) ÷ 2 = <b>4'-0"</b> (1219)	70	70	70	67	55	43	36														
		(A + B) ÷ 2 = <b>3'-6"</b> (1067)	70	70	70	70	61	48	41	33													
		(A + B) ÷ 2 = <b>3'-0"</b> (914)	70	70	70	70	67	53	45	36	31												
		(A + B) ÷ 2 = <b>2'-6"</b> (762)	70	70	70	70	70	62	53	43	37	31											
		(A + B) ÷ 2 = <b>2'-0"</b> (610)	70	70	70	70	70	70	62	50	44	36											
		(A + B) ÷ 2 = <b>1'-6"</b> (457)	70	70	70	70	70	70	70	67	59	49											
		<b>C = (length of join)</b>	<b>5'-6"</b> (1676)	<b>6'-0"</b> (1829)	<b>6'-6"</b> (1981)	<b>7'-0"</b> (2134)	<b>7'-6"</b> (2286)	<b>8'-0"</b> (2438)	<b>8'-6"</b> (2591)	<b>9'-0"</b> (2286)	<b>9'-6"</b> (2438)	<b>10'-0"</b> (2591)											

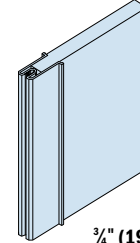
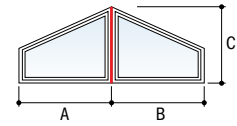

**3/4" (19) x 5 3/4" (146)**  
LVL Joining Material  
For 4 9/16" (116) minimum wall depth

## 1-Way LVL Joining

### A-Series: Factory-Joined Specialty-to-Specialty Windows

<b>6 9/16" (167)</b> Minimum Wall Depth	Average Adjacent Window Dimension	(A + B) ÷ 2 = <b>10'-0"</b> (3048)	70	70	70	70	66	54	42	35													
		(A + B) ÷ 2 = <b>9'-6"</b> (2896)	70	70	70	70	70	66	54	42	35												
		(A + B) ÷ 2 = <b>9'-0"</b> (2743)	70	70	70	70	70	66	54	42	35												
		(A + B) ÷ 2 = <b>8'-6"</b> (2591)	70	70	70	70	70	66	54	42	35												
		(A + B) ÷ 2 = <b>8'-0"</b> (2438)	70	70	70	70	70	66	54	42	36												
		(A + B) ÷ 2 = <b>7'-6"</b> (2286)	70	70	70	70	70	67	55	43	36												
		(A + B) ÷ 2 = <b>7'-0"</b> (2134)	70	70	70	70	70	67	56	44	37												
		(A + B) ÷ 2 = <b>6'-6"</b> (1981)	70	70	70	70	70	69	57	45	39												
		(A + B) ÷ 2 = <b>6'-0"</b> (1829)	70	70	70	70	70	70	59	47	40												
		(A + B) ÷ 2 = <b>5'-6"</b> (1676)	70	70	70	70	70	70	62	49	42												
		(A + B) ÷ 2 = <b>5'-0"</b> (1524)	70	70	70	70	70	70	65	52	44												
		(A + B) ÷ 2 = <b>4'-6"</b> (1372)	70	70	70	70	70	70	70	56	48	40											
		(A + B) ÷ 2 = <b>4'-0"</b> (1219)	70	70	70	70	70	70	70	60	52	42											
		(A + B) ÷ 2 = <b>3'-6"</b> (1067)	70	70	70	70	70	70	70	67	58	48											
		(A + B) ÷ 2 = <b>3'-0"</b> (914)	70	70	70	70	70	70	70	70	64	53											
		(A + B) ÷ 2 = <b>2'-6"</b> (762)	70	70	70	70	70	70	70	70	70	63											
		(A + B) ÷ 2 = <b>2'-0"</b> (610)	70	70	70	70	70	70	70	70	70	70											
		(A + B) ÷ 2 = <b>1'-6"</b> (457)	70	70	70	70	70	70	70	70	70	70											
		<b>C = (length of join)</b>	<b>5'-6"</b> (1676)	<b>6'-0"</b> (1829)	<b>6'-6"</b> (1981)	<b>7'-0"</b> (2134)	<b>7'-6"</b> (2286)	<b>8'-0"</b> (2438)	<b>8'-6"</b> (2591)	<b>9'-0"</b> (2286)	<b>9'-6"</b> (2438)	<b>10'-0"</b> (2591)											

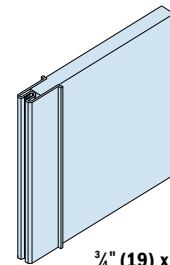
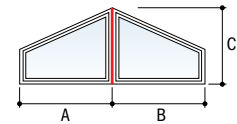

**3/4" (19) x 7 3/4" (197)**  
LVL Joining Material  
For 6 9/16" (167) minimum wall depth

• Numeric value represents the certified Performance Grade (PG) rating of the combination.  
 • Structural performance of any combination is only as high as the lowest structural performance of any individual unit or joining material in the combination.  
 • Andersen® products must be installed and anchored properly according to joining and installation guides to meet rated structural performance. Refer to product joining and installation guides at andersenwindows.com.  
 • Dimensions in parentheses are in millimeters.  
 • See Florida Product Approval documents for additional details on structural joining and performance ratings.

**2-Way LVL Joining**

A-Series: Factory-Joined Specialty-to-Specialty Windows

<b>4 9/16" (116)</b> Minimum Wall Depth	Average Adjacent Window Dimension	(A + B) + 2 = <b>6'-6"</b> (1981)	42	31																
		(A + B) + 2 = <b>6'-0"</b> (1829)	45	33																
		(A + B) + 2 = <b>5'-6"</b> (1676)	50	37	30															
		(A + B) + 2 = <b>5'-0"</b> (1524)	54	40	32															
		(A + B) + 2 = <b>4'-6"</b> (1372)	61	45	37															
		(A + B) + 2 = <b>4'-0"</b> (1219)	67	49	40	31														
		(A + B) + 2 = <b>3'-6"</b> (1067)	70	58	47	36	31													
		(A + B) + 2 = <b>3'-0"</b> (914)	70	65	54	41	35													
		(A + B) + 2 = <b>2'-6"</b> (762)	70	70	66	51	43	34												
		(A + B) + 2 = <b>2'-0"</b> (610)	70	70	70	61	52	41	35											
		(A + B) + 2 = <b>1'-6"</b> (457)	70	70	70	70	70	57	49	40	35									
<b>C = (length of join)</b>	<b>5'-6"</b> (1676)	<b>6'-0"</b> (1829)	<b>6'-6"</b> (1981)	<b>7'-0"</b> (2134)	<b>7'-6"</b> (2286)	<b>8'-0"</b> (2438)	<b>8'-6"</b> (2591)	<b>9'-0"</b> (2744)	<b>9'-6"</b> (2896)	<b>10'-0"</b> (3048)										

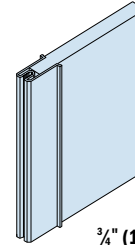
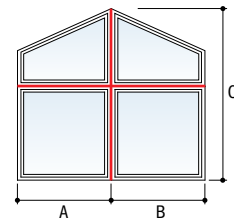

**3/4" (19) x 5 3/4" (146)**  
**LVL Joining Material**

For 4 9/16" (116) minimum wall depth

**2-Way LVL Joining**

A-Series: Factory-Joined Specialty-to-Specialty Windows

<b>6 9/16" (167)</b> Minimum Wall Depth	Average Adjacent Window Dimension	(A + B) + 2 = <b>10'-0"</b> (3048)	69	49	40	31														
		(A + B) + 2 = <b>9'-6"</b> (2896)	70	52	42	33														
		(A + B) + 2 = <b>9'-0"</b> (2743)	70	54	44	34														
		(A + B) + 2 = <b>8'-6"</b> (2591)	70	58	47	37	31													
		(A + B) + 2 = <b>8'-0"</b> (2438)	70	61	50	38	32													
		(A + B) + 2 = <b>7'-6"</b> (2286)	70	65	54	41	35													
		(A + B) + 2 = <b>7'-0"</b> (2134)	70	69	57	44	37													
		(A + B) + 2 = <b>6'-6"</b> (1981)	70	70	62	48	40	32												
		(A + B) + 2 = <b>6'-0"</b> (1829)	70	70	66	51	43	34	30											
		(A + B) + 2 = <b>5'-6"</b> (1676)	70	70	70	56	48	38	33											
		(A + B) + 2 = <b>5'-0"</b> (1524)	70	70	70	61	51	41	35											
		(A + B) + 2 = <b>4'-6"</b> (1372)	70	70	70	69	58	46	40	33										
		(A + B) + 2 = <b>4'-0"</b> (1219)	70	70	70	70	64	51	44	36	32									
		(A + B) + 2 = <b>3'-6"</b> (1067)	70	70	70	70	70	59	51	42	37	31								
		(A + B) + 2 = <b>3'-0"</b> (914)	70	70	70	70	70	67	58	48	42	35								
		(A + B) + 2 = <b>2'-6"</b> (762)	70	70	70	70	70	80	71	59	51	43								
		(A + B) + 2 = <b>2'-0"</b> (610)	70	70	70	70	70	80	80	70	62	52								
(A + B) + 2 = <b>1'-6"</b> (457)	70	70	70	70	70	80	80	80	70	70										
<b>C = (length of join)</b>	<b>5'-6"</b> (1676)	<b>6'-0"</b> (1829)	<b>6'-6"</b> (1981)	<b>7'-0"</b> (2134)	<b>7'-6"</b> (2286)	<b>8'-0"</b> (2438)	<b>8'-6"</b> (2591)	<b>9'-0"</b> (2744)	<b>9'-6"</b> (2896)	<b>10'-0"</b> (3048)										

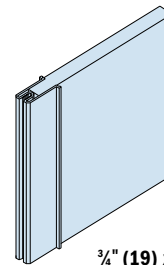
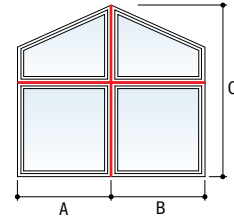

**3/4" (19) x 7 3/4" (197)**  
**LVL Joining Material**

For 6 9/16" (167) minimum wall depth

- Numeric value represents the certified Performance Grade (PG) rating of the combination.
- Structural performance of any combination is only as high as the lowest structural performance of any individual unit or joining material in the combination.
- Andersen® products must be installed and anchored properly according to joining and installation guides to meet rated structural performance. Refer to product joining and installation guides at andersenwindows.com.
- Dimensions in parentheses are in millimeters.
- See Florida Product Approval documents for additional details on structural joining and performance ratings.

**1-Way Fiberglass Joining**

A-Series: Frenchwood® Gliding Patio Doors, Hinged Patio Doors, Patio Door Sidelights and Transoms

<b>4 9/16" (116)</b> Minimum Wall Depth	(A + B) ÷ 2 = <b>12'-0"</b> (3658)	70	70	70	70	70	70	70	70	70	70	70	70	70	67
	(A + B) ÷ 2 = <b>11'-6"</b> (3505)	70	70	70	70	70	70	70	70	70	70	70	70	70	67
	(A + B) ÷ 2 = <b>11'-0"</b> (3353)	70	70	70	70	70	70	70	70	70	70	70	70	70	67
	(A + B) ÷ 2 = <b>10'-6"</b> (3200)	70	70	70	70	70	70	70	70	70	70	70	70	70	67
	(A + B) ÷ 2 = <b>10'-0"</b> (3048)	70	70	70	70	70	70	70	70	70	70	70	70	70	67
	(A + B) ÷ 2 = <b>9'-6"</b> (2896)	70	70	70	70	70	70	70	70	70	70	70	70	70	67
	(A + B) ÷ 2 = <b>9'-0"</b> (2743)	70	70	70	70	70	70	70	70	70	70	70	70	70	67
	(A + B) ÷ 2 = <b>8'-6"</b> (2591)	70	70	70	70	70	70	70	70	70	70	70	70	70	67
	(A + B) ÷ 2 = <b>8'-0"</b> (2438)	70	70	70	70	70	70	70	70	70	70	70	70	70	67
	(A + B) ÷ 2 = <b>7'-6"</b> (2286)	70	70	70	70	70	70	70	70	70	70	70	70	70	67
	(A + B) ÷ 2 = <b>7'-0"</b> (2134)	70	70	70	70	70	70	70	70	70	70	70	70	70	68
	(A + B) ÷ 2 = <b>6'-6"</b> (1981)	70	70	70	70	70	70	70	70	70	70	70	70	70	70
	(A + B) ÷ 2 = <b>6'-0"</b> (1829)	70	70	70	70	70	70	70	70	70	70	70	70	70	70
	(A + B) ÷ 2 = <b>5'-6"</b> (1676)	70	70	70	70	70	70	70	70	70	70	70	70	70	70
	(A + B) ÷ 2 = <b>5'-0"</b> (1524)	70	70	70	70	70	70	70	70	70	70	70	70	70	70
	(A + B) ÷ 2 = <b>4'-6"</b> (1372)	70	70	70	70	70	70	70	70	70	70	70	70	70	70
	(A + B) ÷ 2 = <b>4'-0"</b> (1219)	70	70	70	70	70	70	70	70	70	70	70	70	70	70
	(A + B) ÷ 2 = <b>3'-6"</b> (1067)	70	70	70	70	70	70	70	70	70	70	70	70	70	70
	(A + B) ÷ 2 = <b>3'-0"</b> (914)	70	70	70	70	70	70	70	70	70	70	70	70	70	70
	(A + B) ÷ 2 = <b>2'-6"</b> (762)	70	70	70	70	70	70	70	70	70	70	70	70	70	70
(A + B) ÷ 2 = <b>2'-0"</b> (610)	70	70	70	70	70	70	70	70	70	70	70	70	70	70	
(A + B) ÷ 2 = <b>1'-6"</b> (457)	70	70	70	70	70	70	70	70	70	70	70	70	70	70	
<b>C = (length of join)</b>	<b>2'-0"</b> (610)	<b>2'-6"</b> (762)	<b>3'-0"</b> (914)	<b>3'-6"</b> (1067)	<b>4'-0"</b> (1219)	<b>4'-6"</b> (1372)	<b>5'-0"</b> (1524)	<b>5'-6"</b> (1676)	<b>6'-0"</b> (1829)	<b>6'-6"</b> (1981)	<b>7'-0"</b> (2134)	<b>7'-6"</b> (2286)	<b>8'-0"</b> (2438)		

continued on next page

**2-Way Fiberglass Joining**

A-Series: Frenchwood® Gliding Patio Doors, Hinged Patio Doors, Patio Door Sidelights and Transoms

<b>4 9/16" (116)</b> Minimum Wall Depth	(A + B) ÷ 2 = <b>12'-0"</b> (3658)	70	70	69	59	52	46	41	38	34	32	29	27	26
	(A + B) ÷ 2 = <b>11'-6"</b> (3505)	70	70	70	62	54	48	43	39	36	33	31	29	27
	(A + B) ÷ 2 = <b>11'-0"</b> (3048)	70	70	70	65	57	50	45	41	38	35	32	30	28
	(A + B) ÷ 2 = <b>10'-6"</b> (3200)	70	70	70	68	59	53	47	43	39	36	34	31	29
	(A + B) ÷ 2 = <b>10'-0"</b> (3048)	70	70	70	70	62	55	50	45	41	38	35	33	31
	(A + B) ÷ 2 = <b>9'-6"</b> (2896)	70	70	70	70	66	58	52	48	44	40	37	35	32
	(A + B) ÷ 2 = <b>9'-0"</b> (2743)	70	70	70	70	69	62	55	50	46	43	39	37	34
	(A + B) ÷ 2 = <b>8'-6"</b> (2591)	70	70	70	70	70	65	59	53	49	45	42	39	36
	(A + B) ÷ 2 = <b>8'-0"</b> (2438)	70	70	70	70	70	69	62	57	52	48	44	41	39
	(A + B) ÷ 2 = <b>7'-6"</b> (2286)	70	70	70	70	70	70	67	60	55	51	47	44	41
	(A + B) ÷ 2 = <b>7'-0"</b> (2134)	70	70	70	70	70	70	70	65	59	55	51	47	44
	(A + B) ÷ 2 = <b>6'-6"</b> (1981)	70	70	70	70	70	70	70	70	64	59	55	51	48
	(A + B) ÷ 2 = <b>6'-0"</b> (1829)	70	70	70	70	70	70	70	70	69	64	59	55	52
	(A + B) ÷ 2 = <b>5'-6"</b> (1676)	70	70	70	70	70	70	70	70	70	70	65	60	56
	(A + B) ÷ 2 = <b>5'-0"</b> (1524)	70	70	70	70	70	70	70	70	70	70	70	67	62
	(A + B) ÷ 2 = <b>4'-6"</b> (1372)	70	70	70	70	70	70	70	70	70	70	70	70	69
	(A + B) ÷ 2 = <b>4'-0"</b> (1219)	70	70	70	70	70	70	70	70	70	70	70	70	70
	(A + B) ÷ 2 = <b>3'-6"</b> (1067)	70	70	70	70	70	70	70	70	70	70	70	70	70
	(A + B) ÷ 2 = <b>3'-0"</b> (914)	70	70	70	70	70	70	70	70	70	70	70	70	70
	(A + B) ÷ 2 = <b>2'-6"</b> (762)	70	70	70	70	70	70	70	70	70	70	70	70	70
(A + B) ÷ 2 = <b>2'-0"</b> (610)	70	70	70	70	70	70	70	70	70	70	70	70	70	
(A + B) ÷ 2 = <b>1'-6"</b> (457)	70	70	70	70	70	70	70	70	70	70	70	70	70	
<b>C = (length of join)</b>	<b>2'-0"</b> (610)	<b>2'-6"</b> (762)	<b>3'-0"</b> (914)	<b>3'-6"</b> (1067)	<b>4'-0"</b> (1219)	<b>4'-6"</b> (1372)	<b>5'-0"</b> (1524)	<b>5'-6"</b> (1676)	<b>6'-0"</b> (1829)	<b>6'-6"</b> (1981)	<b>7'-0"</b> (2134)	<b>7'-6"</b> (2286)	<b>8'-0"</b> (2438)	

\* Numeric value represents the certified Performance Grade (PG) rating of the combination.

\* Structural performance of any combination is only as high as the lowest structural performance of any individual unit or joining material in the combination.

\* Andersen® products must be installed and anchored properly according to joining and installation guides to meet rated structural performance. Refer to product joining and installation guides at andersenwindows.com.

\* Dimensions in parentheses are in millimeters.

\* Frenchwood® hinged inswing patio doors with a 6 9/16" (167) base jamb depth require 7 3/4" (197) fiberglass joining material.

\* See Florida Product Approval documents for additional details on structural joining and performance ratings.

continued on next page

1-Way Fiberglass Joining continued from previous page

52	42	33	27	22			
52	42	33	27	22			
52	42	33	27	22			
52	42	33	27	22			
52	42	33	27	22			
52	42	33	27	23			
52	42	34	27	23			
52	42	34	28	23	20		
53	42	35	29	24	20		
53	43	35	29	25	21		
55	44	37	31	26	22		
56	46	38	32	27	23	20	
59	48	40	34	29	25	21	
62	51	43	36	31	26	23	20
66	55	46	39	33	28	25	21
70	59	50	42	36	31	27	24
70	65	55	47	40	35	30	26
70	70	62	53	45	39	34	30
70	70	70	61	52	45	39	34
70	70	70	62	54	47	41	37
70	70	70	70	70	67	58	51
70	70	70	70	70	70	70	68
<b>8'-6"</b> (2591)	<b>9'-0"</b> (2743)	<b>9'-6"</b> (2896)	<b>10'-0"</b> (3048)	<b>10'-6"</b> (3200)	<b>11'-0"</b> (3353)	<b>11'-6"</b> (3505)	<b>12'-0"</b> (3658)

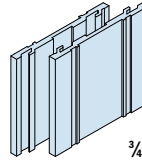
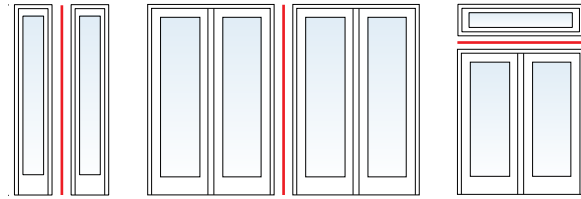

**3/4" (19) x 5 3/4" (146)**  
**Fiberglass Joining Material**  
For 4 9/16" (116) minimum wall depth

2-Way Fiberglass Joining continued from previous page

23	20						
24	21						
25	22	20					
26	23	21					
27	24	22	20				
29	26	23	21				
30	27	24	22	20			
32	29	26	23	21			
34	30	27	25	22	20		
36	32	29	26	24	22	20	
39	35	31	28	25	23	21	
42	38	34	30	27	25	23	21
46	41	36	33	30	27	25	23
50	44	40	36	33	30	27	25
55	49	44	40	36	33	30	27
61	54	49	44	40	36	33	30
69	61	55	50	45	41	37	34
70	54	63	57	51	47	43	39
70	70	70	66	60	55	50	46
70	70	70	70	70	66	60	55
70	70	70	70	70	70	70	69
70	70	70	70	70	70	70	70
<b>8'-6"</b> (2591)	<b>9'-0"</b> (2743)	<b>9'-6"</b> (2896)	<b>10'-0"</b> (3048)	<b>10'-6"</b> (3200)	<b>11'-0"</b> (3353)	<b>11'-6"</b> (3505)	<b>12'-0"</b> (3658)

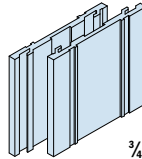
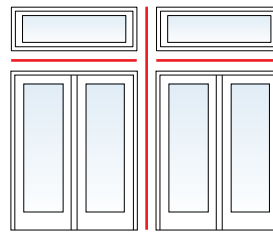

**3/4" (19) x 5 3/4" (146)**  
**Fiberglass Joining Material**  
For 4 9/16" (116) minimum wall depth

- Numeric value represents the certified Performance Grade (PG) rating of the combination.
- Structural performance of any combination is only as high as the lowest structural performance of any individual unit or joining material in the combination.
- Andersen® products must be installed and anchored properly according to joining and installation guides to meet rated structural performance. Refer to product joining and installation guides at andersenwindows.com.
- Dimensions in parentheses are in millimeters.
- Frenchwood® hinged inswing patio doors with a 6 9/16" (167) base jamb depth require 7 3/4" (197) fiberglass joining material.
- See Florida Product Approval documents for additional details on structural joining and performance ratings.

**1-Way Fiberglass Joining**

A-Series: Frenchwood® Gliding Patio Doors, Hinged Patio Doors, Patio Door Sidelights and Transoms

<b>6 9/16" (167)</b> Minimum Wall Depth	Average Adjacent Window Dimension	(A + B) ÷ 2 = <b>12'-0"</b> (3658)	70	70	70	70	70	70	70	70	70	70	70	70	70	
		(A + B) ÷ 2 = <b>11'-6"</b> (3505)	70	70	70	70	70	70	70	70	70	70	70	70	70	70
		(A + B) ÷ 2 = <b>11'-0"</b> (3353)	70	70	70	70	70	70	70	70	70	70	70	70	70	70
		(A + B) ÷ 2 = <b>10'-6"</b> (3200)	70	70	70	70	70	70	70	70	70	70	70	70	70	70
		(A + B) ÷ 2 = <b>10'-0"</b> (3048)	70	70	70	70	70	70	70	70	70	70	70	70	70	70
		(A + B) ÷ 2 = <b>9'-6"</b> (2896)	70	70	70	70	70	70	70	70	70	70	70	70	70	70
		(A + B) ÷ 2 = <b>9'-0"</b> (2743)	70	70	70	70	70	70	70	70	70	70	70	70	70	70
		(A + B) ÷ 2 = <b>8'-6"</b> (2591)	70	70	70	70	70	70	70	70	70	70	70	70	70	70
		(A + B) ÷ 2 = <b>8'-0"</b> (2438)	70	70	70	70	70	70	70	70	70	70	70	70	70	70
		(A + B) ÷ 2 = <b>7'-6"</b> (2286)	70	70	70	70	70	70	70	70	70	70	70	70	70	70
		(A + B) ÷ 2 = <b>7'-0"</b> (2134)	70	70	70	70	70	70	70	70	70	70	70	70	70	70
		(A + B) ÷ 2 = <b>6'-6"</b> (1981)	70	70	70	70	70	70	70	70	70	70	70	70	70	70
		(A + B) ÷ 2 = <b>6'-0"</b> (1829)	70	70	70	70	70	70	70	70	70	70	70	70	70	70
		(A + B) ÷ 2 = <b>5'-6"</b> (1676)	70	70	70	70	70	70	70	70	70	70	70	70	70	70
		(A + B) ÷ 2 = <b>5'-0"</b> (1524)	70	70	70	70	70	70	70	70	70	70	70	70	70	70
		(A + B) ÷ 2 = <b>4'-6"</b> (1372)	70	70	70	70	70	70	70	70	70	70	70	70	70	70
		(A + B) ÷ 2 = <b>4'-0"</b> (1219)	70	70	70	70	70	70	70	70	70	70	70	70	70	70
		(A + B) ÷ 2 = <b>3'-6"</b> (1067)	70	70	70	70	70	70	70	70	70	70	70	70	70	70
		(A + B) ÷ 2 = <b>3'-0"</b> (914)	70	70	70	70	70	70	70	70	70	70	70	70	70	70
		(A + B) ÷ 2 = <b>2'-6"</b> (762)	70	70	70	70	70	70	70	70	70	70	70	70	70	70
(A + B) ÷ 2 = <b>2'-0"</b> (610)	70	70	70	70	70	70	70	70	70	70	70	70	70	70		
(A + B) ÷ 2 = <b>1'-6"</b> (457)	70	70	70	70	70	70	70	70	70	70	70	70	70	70		
<b>C = (length of join)</b>		<b>2'-0"</b> (610)	<b>2'-6"</b> (762)	<b>3'-0"</b> (914)	<b>3'-6"</b> (1067)	<b>4'-0"</b> (1219)	<b>4'-6"</b> (1372)	<b>5'-0"</b> (1524)	<b>5'-6"</b> (1676)	<b>6'-0"</b> (1829)	<b>6'-6"</b> (1981)	<b>7'-0"</b> (2134)	<b>7'-6"</b> (2286)	<b>8'-0"</b> (2438)		

continued on next page

**2-Way Fiberglass Joining**

A-Series: Frenchwood® Gliding Patio Doors, Hinged Patio Doors, Patio Door Sidelights and Transoms

<b>6 9/16" (167)</b> Minimum Wall Depth	Average Adjacent Window Dimension	(A + B) ÷ 2 = <b>12'-0"</b> (3658)	70	70	70	70	62	55	50	45	41	38	35	33	31	
		(A + B) ÷ 2 = <b>11'-6"</b> (3505)	70	70	70	70	65	58	52	47	43	40	37	34	34	32
		(A + B) ÷ 2 = <b>11'-0"</b> (3048)	70	70	70	70	60	54	49	45	42	39	36	34	34	32
		(A + B) ÷ 2 = <b>10'-6"</b> (3200)	70	70	70	70	63	57	51	47	44	40	38	35	35	33
		(A + B) ÷ 2 = <b>10'-0"</b> (3048)	70	70	70	70	70	66	60	54	50	48	42	40	40	37
		(A + B) ÷ 2 = <b>9'-6"</b> (2896)	70	70	70	70	70	70	63	57	52	52	48	45	42	39
		(A + B) ÷ 2 = <b>9'-0"</b> (2743)	70	70	70	70	70	70	66	60	55	51	47	44	44	41
		(A + B) ÷ 2 = <b>8'-6"</b> (2591)	70	70	70	70	70	70	70	64	58	54	50	47	47	44
		(A + B) ÷ 2 = <b>8'-0"</b> (2438)	70	70	70	70	70	70	70	68	62	57	53	50	50	46
		(A + B) ÷ 2 = <b>7'-6"</b> (2286)	70	70	70	70	70	70	70	70	66	61	57	53	53	50
		(A + B) ÷ 2 = <b>7'-0"</b> (2134)	70	70	70	70	70	70	70	70	70	65	61	57	57	53
		(A + B) ÷ 2 = <b>6'-6"</b> (1981)	70	70	70	70	70	70	70	70	70	65	61	57	57	54
		(A + B) ÷ 2 = <b>6'-0"</b> (1829)	70	70	70	70	70	70	70	70	70	70	70	66	66	62
		(A + B) ÷ 2 = <b>5'-6"</b> (1676)	70	70	70	70	70	70	70	70	70	70	70	70	70	68
		(A + B) ÷ 2 = <b>5'-0"</b> (1524)	70	70	70	70	70	70	70	70	70	70	70	70	70	70
		(A + B) ÷ 2 = <b>4'-6"</b> (1372)	70	70	70	70	70	70	70	70	70	70	70	70	70	70
		(A + B) ÷ 2 = <b>4'-0"</b> (1219)	70	70	70	70	70	70	70	70	70	70	70	70	70	70
		(A + B) ÷ 2 = <b>3'-6"</b> (1067)	70	70	70	70	70	70	70	70	70	70	70	70	70	70
		(A + B) ÷ 2 = <b>3'-0"</b> (914)	70	70	70	70	70	70	70	70	70	70	70	70	70	70
		(A + B) ÷ 2 = <b>2'-6"</b> (762)	70	70	70	70	70	70	70	70	70	70	70	70	70	70
(A + B) ÷ 2 = <b>2'-0"</b> (610)	70	70	70	70	70	70	70	70	70	70	70	70	70	70		
(A + B) ÷ 2 = <b>1'-6"</b> (457)	70	70	70	70	70	70	70	70	70	70	70	70	70	70		
<b>C = (length of join)</b>		<b>2'-0"</b> (610)	<b>2'-6"</b> (762)	<b>3'-0"</b> (914)	<b>3'-6"</b> (1067)	<b>4'-0"</b> (1219)	<b>4'-6"</b> (1372)	<b>5'-0"</b> (1524)	<b>5'-6"</b> (1676)	<b>6'-0"</b> (1829)	<b>6'-6"</b> (1981)	<b>7'-0"</b> (2134)	<b>7'-6"</b> (2286)	<b>8'-0"</b> (2438)		

\* Numeric value represents the certified Performance Grade (PG) rating of the combination.

\* Structural performance of any combination is only as high as the lowest structural performance of any individual unit or joining material in the combination.

\* Andersen® products must be installed and anchored properly according to joining and installation guides to meet rated structural performance. Refer to product joining and installation guides at andersenwindows.com.

\* Dimensions in parentheses are in millimeters.

\* Frenchwood® hinged inswing patio doors with a 6 9/16" (167) base jamb depth require 7 3/4" (197) fiberglass joining material.

\* See Florida Product Approval documents for additional details on structural joining and performance ratings.

continued on next page



1-Way Fiberglass Joining continued from previous page

70	64	58	52	47	39	33	28	23	20		
70	64	58	52	47	39	33	28	23	20		
70	64	58	52	47	39	33	28	23	20		
70	64	58	52	47	39	33	28	24	21		
70	64	58	52	47	40	34	29	24	21		
70	64	58	52	48	40	34	29	25	22		
70	64	58	53	48	41	35	30	25	22		
70	65	58	53	49	42	36	31	26	23	20	
70	65	59	54	50	43	37	32	27	24	21	
70	66	60	56	51	45	39	33	29	25	22	20
70	68	62	57	53	47	40	35	30	26	23	21
70	70	64	59	55	49	43	37	32	28	25	22
70	70	67	62	58	52	45	39	34	30	26	24
70	70	70	65	61	56	48	42	36	32	29	25
70	70	70	70	65	60	52	46	40	35	33	28
70	70	70	70	70	66	57	52	44	38	34	30
70	70	70	70	70	70	64	56	48	43	38	34
70	70	70	70	70	70	70	63	55	49	43	39
70	70	70	70	70	70	70	70	64	56	50	45
70	70	70	70	70	70	70	70	70	67	60	54
70	70	70	70	70	70	70	70	70	70	70	67
70	70	70	70	70	70	70	70	70	70	70	70
<b>8'-6"</b> (2591)	<b>9'-0"</b> (2743)	<b>9'-6"</b> (2896)	<b>10'-0"</b> (3048)	<b>10'-6"</b> (3200)	<b>11'-0"</b> (3353)	<b>11'-6"</b> (3505)	<b>12'-0"</b> (3658)	<b>12'-6"</b> (3810)	<b>13'-0"</b> (3962)	<b>13'-6"</b> (4115)	<b>14'-0"</b> (4267)

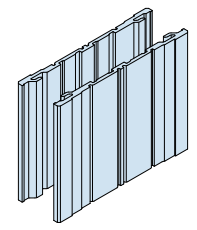
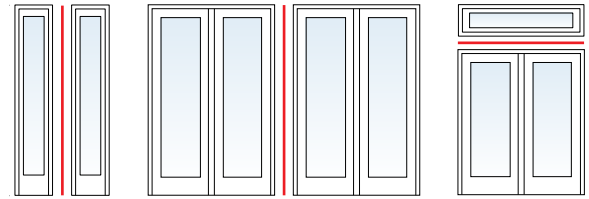

**¾" (19) x 7 ¾" (197)  
Fiberglass Joining Material**

For higher performance for 1-way and 2-way joining and it is required for Frenchwood® hinged inswing patio doors with 6 7/16" (167) base jamb depths

2-Way Fiberglass Joining continued from previous page

24	23	22	20								
25	24	23	21	20							
26	25	24	22	21	20						
28	26	25	23	22	21	20					
29	27	26	25	23	22	21	20				
31	29	27	26	25	24	23	22				
32	31	29	27	26	25	24	23	21			
34	32	31	29	28	26	25	24	22	21		
37	34	33	31	29	28	27	26	24	22	20	
39	37	35	33	31	30	29	27	25	23	22	20
42	39	37	35	34	32	31	29	27	25	23	22
45	43	40	38	36	35	33	32	29	27	25	23
49	46	44	41	39	38	36	34	32	29	27	26
53	50	48	45	43	41	39	38	35	32	30	28
59	55	52	50	47	45	43	42	38	35	33	30
65	62	58	55	53	50	48	46	43	39	37	34
70	69	66	62	59	57	54	52	48	44	41	38
70	70	70	70	68	65	62	59	55	51	47	44
70	70	70	70	70	70	70	69	64	59	55	51
70	70	70	70	70	70	70	70	70	70	66	61
70	70	70	70	70	70	70	70	70	70	70	70
70	70	70	70	70	70	70	70	70	70	70	70
<b>8'-6"</b> (2591)	<b>9'-0"</b> (2743)	<b>9'-6"</b> (2896)	<b>10'-0"</b> (3048)	<b>10'-6"</b> (3200)	<b>11'-0"</b> (3353)	<b>11'-6"</b> (3505)	<b>12'-0"</b> (3658)	<b>12'-6"</b> (3810)	<b>13'-0"</b> (3962)	<b>13'-6"</b> (4115)	<b>14'-0"</b> (4267)

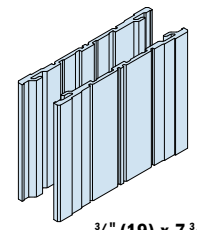
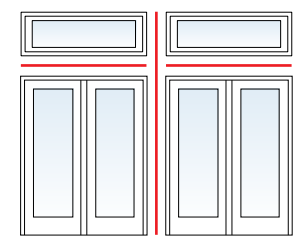

**¾" (19) x 7 ¾" (197)  
Fiberglass Joining Material**

For higher performance for 1-way and 2-way joining and it is required for Frenchwood® hinged inswing patio doors with 6 7/16" (167) base jamb depths

- Numeric value represents the certified Performance Grade (PG) rating of the combination.
- Structural performance of any combination is only as high as the lowest structural performance of any individual unit or joining material in the combination.
- Andersen® products must be installed and anchored properly according to joining and installation guides to meet rated structural performance. Refer to product joining and installation guides at andersenwindows.com.
- Dimensions in parentheses are in millimeters.
- Frenchwood® hinged inswing patio doors with a 6 7/16" (167) base jamb depth require 7 3/4" (197) fiberglass joining material.
- See Florida Product Approval documents for additional details on structural joining and performance ratings.

## PERFORMANCE STANDARDS

The Window and Door Manufacturers Association (WDMA), the American Architectural Manufacturers Association (AAMA) and the Canadian Standards Association (CSA) jointly release the North American Fenestration Standard/Specification for Windows, Doors and Skylights (NAFS-11) where “-11” refers to the most recent publication year of 2011. NAFS is also referred to as AAMA/WDMA/CSA 101/I.S.2/A440, which is how the International Code Council (ICC) lists this standard in the 2012, 2015 and 2018 International Residential Code (IRC) and International Building Code (IBC) as the means to indicate the window, door or skylights design pressure rating used to determine compliance to the jobsite design pressure requirements.

A product only achieves a “Performance Grade” or “PG” rating when it complies with all of the NAFS performance requirements such as ease of operation, air infiltration resistance, resistance to water penetration and resistance to forced entry, etc. A “Design Pressure Rating” or “DP” rating only depicts the design and structural load performance.

### Performance Classes

The NAFS Standard/Specification defines requirements for four performance classes. Performance classes are designated R, LC, CW and AW. This classification system provides for several levels of performance. Product selection is always based on the performance and building code requirements of the particular project.

### Elements of Performance Grade (PG) Designations

In order to qualify for a given performance grade (PG), test specimens need to pass all required performance tests for the following, in addition to all required auxiliary (durability) and applicable material/component tests (not shown here) for the applicable product type and desired performance class:

- (a) Operating force (if applicable):** Maximum operating force varies by product type and performance class.
- (b) Air leakage resistance:** Tested in accordance with ASTM E283 at a test pressure of 1.57 psf. Allowable air infiltration for R, LC and CW class designations is 0.3 cubic feet per minute per square foot of frame (cfm/ft<sup>2</sup>).
- (c) Water penetration resistance:** Tested in accordance with ASTM E547 with the specified test pressure applied per NAFS-11. Test consists of four cycles. Each cycle consists of five minutes with pressure applied and one minute with the pressure released, during which the water spray is continuously applied. Water spray shall be uniformly applied at a constant rate of 5 U.S. gal/ft<sup>2</sup> · hr.
- (d) Uniform load deflection test:** Tested in accordance with ASTM E330 for both positive and negative pressure (pressure defined by NAFS-11) with the load maintained for a period of 10 seconds. The test specimen shall be evaluated for deflection during each load for permanent damage after each load and for any effects on the normal operation of the specimen. *Starting with the 2008 version of NAFS, design pressure (DP) will only represent the “uniform load deflection test.”*
- (e) Uniform load structural test:** Tested in accordance with ASTM E330 for both positive and negative pressure (pressure defined by NAFS-11) with the load maintained for a period of 10 seconds. After loads are removed, there shall be no permanent deformation in excess of 0.4% of its span and no damage to the unit which would make it inoperable.
- (f) Forced-entry resistance (if applicable):** Tested in accordance with ASTM F588 (windows), F476 (swinging doors) and F842 (sliding doors) at a performance level 10 rating.

### Performance Grades (PG) & Corresponding Test Pressures (psf)

Performance Class/Performance Grade		Air Infiltration Test Pressure		Maximum Allowable Air Infiltration/Exfiltration Rate		Water Penetration Resistance Test Pressure		Design Pressure		Structural Test Pressure	
R	LC	Pa	psf	L/s·m <sup>2</sup>	cfm/ft <sup>2</sup>	Pa	psf	Pa	psf	Pa	psf
15	-	75	1.57	1.5	0.30	140	2.92	720	15.04	1080	22.56
20	-	75	1.57	1.5	0.30	150	3.13	960	20.05	1440	30.08
25	25	75	1.57	1.5	0.30	180	3.76	1200	25.06	1800	37.59
30	30	75	1.57	1.5	0.30	220	4.59	1440	30.08	2160	45.11
35	35	75	1.57	1.5	0.30	260	5.43	1680	35.09	2520	52.63
40	40	75	1.57	1.5	0.30	290	6.06	1920	40.10	2880	60.15
45	45	75	1.57	1.5	0.30	330	6.89	2160	45.11	3240	67.67
50	50	75	1.57	1.5	0.30	360	7.52	2400	50.13	3600	75.19
55	55	75	1.57	1.5	0.30	400	8.35	2640	55.14	3960	82.71
60	60	75	1.57	1.5	0.30	440	9.19	2880	60.15	4320	90.23
65	65	75	1.57	1.5	0.30	470	9.82	3120	65.16	4680	97.74
70	70	75	1.57	1.5	0.30	510	10.65	3360	70.18	5040	105.26
75	75	75	1.57	1.5	0.30	540	11.28	3600	75.19	5400	112.78
80	80	75	1.57	1.5	0.30	580	12.11	3840	80.20	5760	120.30
85	85	75	1.57	1.5	0.30	580	12.11	4080	85.21	6120	127.82
90	90	75	1.57	1.5	0.30	580	12.11	4320	90.23	6480	135.34
95	95	75	1.57	1.5	0.30	580	12.11	4560	95.24	6840	142.86
100	100	75	1.57	1.5	0.30	580	12.11	4800	100.25	7200	150.38

## HALLMARK CERTIFICATION

The Window and Door Manufacturers Association (WDMA)-sponsored Hallmark Certification Program provides manufacturers with certification to the AAMA/WDMA/CSA 101/I.S.2/A440-11 Standard and is designed to provide builders, architects, specifiers and consumers with an easily recognizable means of identifying products that have been manufactured and tested in accordance with NAFS (AAMA/WDMA/CSA 101/I.S.2/A440) industry standards and other applicable performance standards. Conformance is determined by periodic in-plant inspections by a third-party administrator. Inspections include auditing licensee quality control procedures and processes and a review to confirm products are manufactured in accordance with the appropriate performance standards. Periodic testing of representative product constructions and components by an independent testing laboratory is also required. When all of the program requirements are met, the licensee is authorized to use the WDMA Hallmark registered logo on their certification label as a means of identifying products and their performance ratings.

Products successfully obtaining Hallmark Certification will be labeled with a three-part code, which includes performance class, performance grade and size tested. In addition to this mandatory requirement, you are allowed to list the design pressure on a separate line.

	<b>Andersen Corporation</b> <b>A-Series Casement Window with Stormwatch® Protection</b> Manufacturer stipulates certification as indicated below.					
	<table border="1"> <thead> <tr> <th>STANDARD</th> <th>RATING</th> </tr> </thead> <tbody> <tr> <td>AAMA/WDMA/CSA 101/I.S.2/A440-11</td> <td>CLASS LC<sup>(1)</sup> - PG70<sup>(2)</sup> - Size Tested 35.3 x 71.3 in.<sup>(3)</sup> DP+70/-70<sup>(4)</sup></td> </tr> <tr> <td>AAMA/WDMA/CSA 101/I.S.2/A440-08</td> <td>CLASS LC<sup>(1)</sup> - PG70<sup>(2)</sup> - Size Tested 35.3 x 71.3 in.<sup>(3)</sup> DP+70/-70<sup>(4)</sup></td> </tr> </tbody> </table>	STANDARD	RATING	AAMA/WDMA/CSA 101/I.S.2/A440-11	CLASS LC <sup>(1)</sup> - PG70 <sup>(2)</sup> - Size Tested 35.3 x 71.3 in. <sup>(3)</sup> DP+70/-70 <sup>(4)</sup>	AAMA/WDMA/CSA 101/I.S.2/A440-08
STANDARD	RATING					
AAMA/WDMA/CSA 101/I.S.2/A440-11	CLASS LC <sup>(1)</sup> - PG70 <sup>(2)</sup> - Size Tested 35.3 x 71.3 in. <sup>(3)</sup> DP+70/-70 <sup>(4)</sup>					
AAMA/WDMA/CSA 101/I.S.2/A440-08	CLASS LC <sup>(1)</sup> - PG70 <sup>(2)</sup> - Size Tested 35.3 x 71.3 in. <sup>(3)</sup> DP+70/-70 <sup>(4)</sup>					

- (1) - Performance Class
- (2) - Performance Grade
- (3) - Size Tested
- (4) - Design Pressure

In the example above, the performance class is LC, the performance grade (PG) is 70 pounds per square foot (psf) and the size tested is 35.3" x 71.3". What this means to the specifier is, based on the performance grade chart, the laboratory-tested air infiltration was less than 0.3 cfm/ft<sup>2</sup> (test pressure is always 1.57 psf and the allowable airflow is 0.3 cfm/ft<sup>2</sup>), the product tested successfully resisted a laboratory water penetration test at a test pressure of 10.65 psf, the product tested successfully withstood a laboratory positive test pressure of 105 psf and a laboratory negative test pressure of 105 psf and the product tested passed the laboratory requirements for operational force and forced-entry resistance. Based on this test, all products of the same design that are smaller than the tested size can be labeled with this product performance rating.

## IMPORTANT

Building codes prescribe design pressure based on a variety of criteria (i.e. windspeed zone, building height, building type, jobsite exposure, etc.). Design pressures derived from Performance Grade (PG) test requirements should be used to determine compliance to building code required design pressures. Structural test pressures, which are tested at 1.5 times the design pressure, should **not** be used for determining design pressure code compliance. In the example above, a PG 70 performance grade rating, which passes a 70 psf design pressure, should be used for determining code compliance, not the structural test pressure of 105 psf.

If you need further details about how Andersen® products perform to this standard, contact your Andersen supplier.

If you need further information about the AAMA/WDMA/CSA 101/I.S.2/A440-11 standard or the Hallmark Certification Program, please contact: WDMA, 330 N. Wabash Avenue Suite 2000, Chicago, IL 60611 Phone: 312-673-4828 Web: wdma.com

Where designated, Andersen products are tested, certified and labeled to the requirements of the Hallmark Certification Program. Actual performance may vary based on variations in manufacturing, shipping, installation, environmental conditions and conditions of use.

**Performance Grade, Air Infiltration and Sound Transmission Ratings**
**A-Series Windows — Low-E4® Impact-Resistant Glass Types**

 For current performance information, please visit [andersenwindows.com](http://andersenwindows.com).

Andersen® Product	AAMA/WDMA/CSA 101/IS2/A440 Performance Grade (PG)	+/- Corresponding Design Pressure (DP)	TAS 201, 202, 203	Standard Glass Sound Transmission Class (STC)	Standard Glass Outdoor/Indoor Transmission Class (OITC)	Air Infiltration CFM/FT <sup>2</sup>
<b>Casement</b> (up to 3060)	Class LC-PG70 Size Tested 35.3" x 71.3"	70/70	70/70	33	24	<0.2
<b>Casement</b> (greater than 3060 but less than or equal to 3680, 31074 & 4068)	Class LC-PG50 Size Tested 47.3" x 79.3" Class LC-PG50 Size Tested 45.3" x 87.3" Class LC-PG50 Size Tested 41.3" x 95.3"	50/50	50/50	33	24	<0.2
<b>Awning</b> (up to 4040, 4430 & 5028)	Class LC-PG70 Size Tested 47.3" x 47.3" Class LC-PG70 Size Tested 51.3" x 35.3" Class LC-PG70 Size Tested 59.3" x 31.3"	70/70	70/70	33	30	<0.2
<b>Awning</b> (greater than 4040, 4430 & 5028 but less than or equal to 6040)	Class LC-PG50 Size Tested 71.3" x 47.3"	50/50	50/50	33	30	< 0.2
<b>Double-Hung</b>	Class LC-PG70 Size Tested 47.3" x 95.3"	70/70	70/70	32	29	< 0.2
<b>Picture</b>	Class LC -PG70 Size Tested 71.3" x 79.3"	70/70	70/70	34	31	< 0.2
<b>Picture</b>	Class LC -PG65 Size Tested 71.3" x 95.3"	65/65	65/65	34	31	< 0.2
<b>Fixed Transom</b>	Class R -PG70 Size Tested 55.3" x 55.3" Class R -PG70 Size Tested 95.3" x 39.3"	70/70	70/70	33	29	< 0.2
<b>Venting Transom</b>	Class R-PG70 Size Tested 59.3" x 31.3"	70/70	70/70	33	29	< 0.2
<b>Direct-Set Specialty</b>						
<b>Springline™</b> (up to 50 sq. ft.)	Class LC-PG70 Size Tested 60" x 120"	70/80	70/80	37	31	< 0.2
<b>Springline</b> (up to 36 sq. ft.)	Class LC-PG70 Size Tested 54" x 96"	70/70	70/70	36	31	< 0.2
<b>Springline</b> (up to 15 sq. ft.)	Class LC-PG70 Size Tested 36" x 60"	70/70	70/70	35	30	< 0.2
<b>Arch</b> (up to 50 sq. ft.)	Class LC-PG70 Size Tested 60" x 120"	70/80	70/80	37	31	< 0.2
<b>Arch</b> (up to 36 sq. ft.)	Class LC-PG70 Size Tested 54" x 96"	70/70	70/70	36	31	< 0.2
<b>Arch</b> (up to 15 sq. ft.)	Class LC-PG70 Size Tested 36" x 60"	70/70	70/70	35	30	< 0.2
<b>Sash-Set Specialty</b>						
<b>Springline™</b> (up to 50 sq. ft.)	Class LC-PG70 Size Tested 60" x 120"	70/80	70/80	37	34	< 0.2
<b>Springline</b> (up to 36 sq. ft.)	Class LC-PG70 Size Tested 54" x 96"	70/70	70/70	37	34	< 0.2
<b>Springline</b> (up to 15 sq. ft.)	Class LC-PG70 Size Tested 36" x 96"	70/70	70/70	36	32	< 0.2
<b>Arch</b> (up to 50 sq. ft.)	Class LC-PG70 Size Tested 60" x 120"	70/80	70/80	37	34	< 0.2
<b>Arch</b> (up to 36 sq. ft.)	Class LC-PG70 Size Tested 54" x 96"	70/70	70/70	37	34	< 0.2
<b>Arch</b> (up to 15 sq. ft.)	Class LC-PG70 Size Tested 36" x 96"	70/70	70/70	36	32	< 0.2

 Combination Designs,  
Product Performance  
& Installation

 For a listing of helpful links related to performance, test reports and regulations, visit [andersenwindows.com/coastalperformance](http://andersenwindows.com/coastalperformance).

- \*Performance Grade (PG) ratings may vary from tested performance rating for larger or smaller units of a particular type.
- \*Sound Transmission Class (STC) & \*Outdoor/Indoor Transmission Class (OITC) ratings are for individual units based on independent tests and represent entire unit. Higher STC/OITC values may be available with other glazings.
- This data is accurate as of October 2019. Due to ongoing product changes, updated test results or new industry standards, this data may change over time.
- Where designated, Andersen products are certified and labeled to the requirements of the Hallmark Certification Program. Actual performance may vary based on variations in manufacturing, shipping, installation, environmental conditions and conditions of use.
- Contact your Andersen supplier or go to [andersenwindows.com](http://andersenwindows.com) for more information.
- All impact resistant glass units, except sidelight transom, tested to Large Missile D, Wind Zone 4 and High Velocity Hurricane Zone (HVHZ) requirements of Florida.

**Performance Grade, Air Infiltration and Sound Transmission Ratings**

A-Series Patio Doors with Performance Grade (PG) Upgrades – Low-E4® Impact-Resistant Glass Types

For current performance information, please visit [andersenwindows.com](http://andersenwindows.com).

Andersen® Product	AAMA/WDMA/CSA 101/IS2/A440 Performance Grade (PG)	+/- Corresponding Design Pressure (DP)	TAS 201, 202, 203	Standard Glass Sound Transmission Class (STC)	Standard Glass Outdoor/Indoor Transmission Class (OITC)	Air Infiltration CFM/FT <sup>2</sup>
<b>Frenchwood® Gliding Patio Door</b>						
<b>Single, Stationary (80)</b>	Class LC-PG65 Size Tested 50.4" x 95.5"	65/80	65/70	36	31	< 0.2
<b>Two-Panel (611)</b>	Class LC-PG70 Size Tested 95.3" x 82.5"	70/80	70/80	31	29	< 0.2
<b>Two-Panel (80)</b>	Class LC-PG70 Size Tested 95.3" x 95.5"	70/70	70/70	31	29	< 0.2
<b>Three-Panel (611)</b>	Class LC-PG65 Size Tested 141.0" x 82.5"	65/70	65/70	†	†	< 0.2
<b>Three-Panel (80)</b>	Class LC-PG50 Size Tested 141.0" x 95.5"	50/50	50/50	†	†	< 0.2
<b>Four-Panel (611)</b>	Class LC-PG65 Size Tested 189.0" x 82.4"	65/70	65/70	†	†	< 0.2
<b>Four-Panel (80)</b>	Class LC-PG50 Size Tested 189.0" x 95.5"	50/50	50/50	†	†	< 0.2
<b>Frenchwood® Hinged Inswing Patio Door</b>						
<b>Single, Stationary (611)</b>	Class LC-PG65 Size Tested 38.0" x 82.5"	65/80	65/80	34	30	< 0.2
<b>Single, Stationary (80)</b>	Class LC-PG65 Size Tested 38.0" x 95.5"	65/70	65/70	34	30	< 0.2
<b>Single, Active (611)</b>	Class LC-PG65 Size Tested 38.0" x 82.5"	65/80	65/80	34	30	< 0.2
<b>Single, Active (80)</b>	Class LC-PG65 Size Tested 38.0" x 95.5"	65/70	65/70	34	30	< 0.2
<b>Two-Panel, AP/PA (611)</b>	Class LC-PG65 Size Tested 75.3" x 82.5"	65/80	65/80	33	30	< 0.2
<b>Two-Panel, AP/PA (80)</b>	Class LC-PG65 Size Tested 75.3" x 95.5"	65/70	65/70	33	30	< 0.2
<b>Two-Panel, AS/SA/SS (611)</b>	Class LC-PG65 Size Tested 75.3" x 82.5"	65/80	–	33	30	< 0.2
<b>Two-Panel, AS/SA/SS (80)</b>	Class LC-PG65 Size Tested 75.3" x 95.5"	65/70	–	33	30	< 0.2
<b>Frenchwood® Hinged Outswing Patio Door</b>						
<b>Single, Stationary (611, 80)</b>	Class LC-PG65 Size Tested 38.0" x 95.5"	65/80	65/80	35	30	< 0.2
<b>Single, Active (611)</b>	Class R-PG65 Size Tested 38.0" x 82.5"	65/80	65/80	35	30	< 0.2
<b>Single, Active (80)</b>	Class R-PG65 Size Tested 38.0" x 95.3"	65/70	65/70	35	30	< 0.2
<b>Two-Panel (611)</b>	Class LC-PG65 Size Tested 75.3" x 82.5"	65/80	65/80	34	30	< 0.2
<b>Two-Panel (80)</b>	Class LC-PG65 Size Tested 75.3" x 95.5"	65/70	65/70	34	30	< 0.2
<b>Frenchwood® Patio Door Sidelights &amp; Transoms</b>						
<b>Transom</b>	Class LC-PG70 Size Tested 112.0" x 27.0"	70/80	70/80	†	†	< 0.2
<b>Sidelight Transom</b>	Class LC-PG70 Size Tested 18.0" x 27.0"	70/80	70/80	†	†	< 0.2
<b>Sidelight (611, 80)</b>	Class LC-PG70 Size Tested 18.0" x 95.5"	70/80	70/80	†	†	< 0.2

For a listing of helpful links related to performance, test reports and regulations, visit [andersenwindows.com/coastalperformance](http://andersenwindows.com/coastalperformance).

- \* "Performance Grade (PG)" ratings may vary from tested performance rating for larger or smaller units of a particular type.
- \*\* "Sound Transmission Class (STC)" & "Outdoor/Indoor Transmission Class (OITC)" ratings are for individual units based on independent tests and represent entire unit. Higher STC/OITC values may be available with other glazings.
- \* This data is accurate as of October 2019. Due to ongoing product changes, updated test results or new industry standards, this data may change over time.
- \* Where designated, Andersen products are certified and labeled to the requirements of the Hallmark Certification Program. Actual performance may vary based on variations in manufacturing, shipping, installation, environmental conditions and conditions of use.
- \* Contact your Andersen supplier or go to [andersenwindows.com](http://andersenwindows.com) for more information.
- \* All impact resistant glass units, except sidelight transom, tested to Large Missile D, Wind Zone 4 and High Velocity Hurricane Zone (HVHZ) requirements of Florida.
- † Data not available.

**Performance Grade, Air Infiltration and Sound Transmission Ratings**
**A-Series Patio Doors with Performance Grade (PG) Upgrades – Monolithic Impact-Resistant Glass Types**

 For current performance information, please visit [andersenwindows.com](http://andersenwindows.com).

Andersen® Product	AAMA/WDMA/CSA 101/IS2/A440 Performance Grade (PG)	+/- Corresponding Design Pressure (DP)	TAS 201, 202, 203	Standard Glass Sound Transmission Class (STC)	Standard Glass Outdoor/Indoor Transmission Class (OITC)	Air Infiltration CFM/FT <sup>2</sup>
<b>Frenchwood® Gliding Patio Door</b>						
Single, Stationary (611, 80)	–	–	65/80	–	–	< 0.2
Two-Panel (611)	–	–	70/80	–	–	< 0.2
Two-Panel (80)	–	–	70/70	–	–	< 0.2
Three-Panel (611)	–	–	65/70	–	–	< 0.2
Three-Panel (80)	–	–	50/50	–	–	< 0.2
Four-Panel (611)	–	–	65/70	–	–	< 0.2
Four-Panel (80)	–	–	50/50	–	–	< 0.2
<b>Frenchwood® Hinged Inswing Patio Door</b>						
Single, Stationary (611)	–	–	65/80	–	–	< 0.2
Single, Stationary (80)	–	–	65/70	–	–	< 0.2
Single, Active (611)	–	–	65/80	–	–	< 0.2
Single, Active (80)	–	–	65/70	–	–	< 0.2
Two-Panel, AP/PA (611)	–	–	65/80	–	–	< 0.2
Two-Panel, AP/PA (80)	–	–	65/70	–	–	< 0.2
Two-Panel, AS/SA/SS (611)	–	–	–	–	–	–
Two-Panel, AS/SA/SS (80)	–	–	–	–	–	–
<b>Frenchwood® Hinged Outswing Patio Door</b>						
Single, Stationary (611, 80)	–	–	65/80	–	–	< 0.2
Single, Active (611)	–	–	65/80	–	–	< 0.2
Single, Active (80)	–	–	65/70	–	–	< 0.2
Two-Panel (611)	–	–	65/80	–	–	< 0.2
Two-Panel (80)	–	–	65/70	–	–	< 0.2
<b>Frenchwood® Patio Door Sidelights &amp; Transoms</b>						
Transom	–	–	70/80	–	–	< 0.2
Sidelight Transom	–	–	70/80	–	–	< 0.2
Sidelight (611, 80)	–	–	70/80	–	–	< 0.2

Combination Designs, Product Performance &amp; Installation

 For a listing of helpful links related to performance, test reports and regulations, visit [andersenwindows.com/coastalperformance](http://andersenwindows.com/coastalperformance).

- \*Performance Grade (PG) ratings may vary from tested performance rating for larger or smaller units of a particular type.
- \*Sound Transmission Class (STC) & \*Outdoor/Indoor Transmission Class (OITC) ratings are for individual units based on independent tests and represent entire unit. Higher STC/OITC values may be available with other glazings.
- This data is accurate as of October 2019. Due to ongoing product changes, updated test results or new industry standards, this data may change over time.
- Where designated, Andersen products are certified and labeled to the requirements of the Hallmark Certification Program. Actual performance may vary based on variations in manufacturing, shipping, installation, environmental conditions and conditions of use.
- Contact your Andersen supplier or go to [andersenwindows.com](http://andersenwindows.com) for more information.
- All impact resistant glass units, except sidelight transom, tested to Large Missile D, Wind Zone 4 and High Velocity Hurricane Zone (HVHZ) requirements of Florida.

**Center of Glass Performance Data – Low-E4® Impact-Resistant Glass**

For current performance information, please visit [andersenwindows.com](http://andersenwindows.com).

Andersen® Product	VT <sup>1</sup>	SC <sup>2</sup>	SHGC <sup>3</sup>	RHG <sup>4</sup>	Fading		%RH @ center <sup>7</sup>	IGST <sup>8</sup>
					Tuv <sup>5</sup>	Tdw <sup>6</sup>		
<b>A-Series Windows</b>								
Casement	70%	0.47	0.41	98	< 1%	23%	59%	55°F
Awning	70%	0.47	0.41	98	< 1%	23%	59%	55°F
Double-Hung	70%	0.47	0.41	98	< 1%	23%	59%	55°F
Stationary Transom	70%	0.47	0.41	97	< 1%	21%	57%	54°F
Venting Transom	70%	0.47	0.41	98	< 1%	23%	59%	55°F
Picture	70%	0.47	0.41	97	< 1%	21%	57%	54°F
Specialty	70%	0.47	0.41	97	< 1%	21%	57%	54°F
<b>A-Series Frenchwood® Patio Doors, Patio Door Transoms &amp; Sidelights and Venting Transom Windows</b>								
Gliding	70%	0.47	0.41	97	< 1%	21%	57%	54°F
Hinged Inswing	70%	0.47	0.41	97	< 1%	21%	57%	54°F
Hinged Outswing	70%	0.47	0.41	97	< 1%	21%	57%	54°F
Transom	69%	0.46	0.40	97	< 1%	17%	57%	54°F
Sidelight	70%	0.47	0.41	98	< 1%	21%	57%	54°F
Venting Transom	70%	0.47	0.41	98	< 1%	21%	57%	54°F

**Center of Glass Performance Data – Low-E4® SmartSun™ Impact-Resistant Glass**

For current performance information, please visit [andersenwindows.com](http://andersenwindows.com).

Andersen® Product	VT <sup>1</sup>	SC <sup>2</sup>	SHGC <sup>3</sup>	RHG <sup>4</sup>	Fading		%RH @ center <sup>7</sup>	IGST <sup>8</sup>
					Tuv <sup>5</sup>	Tdw <sup>6</sup>		
<b>A-Series Windows</b>								
Casement	63%	0.32	0.28	67	< 1%	17%	59%	55°F
Awning	63%	0.32	0.28	67	< 1%	17%	59%	55°F
Double-Hung	63%	0.32	0.28	67	< 1%	17%	59%	55°F
Stationary Transom	63%	0.32	0.28	67	< 1%	16%	57%	54°F
Venting Transom	63%	0.32	0.28	67	< 1%	17%	59%	55°F
Picture	63%	0.32	0.28	67	< 1%	16%	57%	54°F
Specialty	63%	0.32	0.28	67	< 1%	16%	57%	54°F
<b>A-Series Frenchwood® Patio Doors, Patio Door Transoms &amp; Sidelights and Venting Transom Windows</b>								
Gliding	63%	0.32	0.28	67	< 1%	16%	57%	54°F
Hinged Inswing	63%	0.32	0.28	67	< 1%	16%	57%	54°F
Hinged Outswing	63%	0.32	0.28	67	< 1%	16%	57%	54°F
Transom	63%	0.32	0.28	67	< 1%	14%	59%	55°F
Sidelight	63%	0.32	0.27	67	< 1%	16%	57%	54°F
Venting Transom	63%	0.32	0.27	67	< 1%	16%	57%	54°F

For a listing of helpful links related to performance, test reports and regulations, visit [andersenwindows.com/coastalperformance](http://andersenwindows.com/coastalperformance).

\* "Low-E4™", "Low-E4® SmartSun™" and "Low-E4® Sun" are Andersen trademarks for "Low-E" glass.  
 • Based on NFRC testing/simulation conditions using Windows v7.3.4.0 and NFRC validated spectral data. 0°F outside temperature, 70°F inside temperature and a 15 mph wind.  
 1) Visible Transmittance (VT) measures how much light comes through the glass. The higher the value, from 0 to 1, the more daylight the glass lets in. Visible Transmittance is measured over the 380 to 760 nanometer portion of the solar spectrum. 2) Shading Coefficient defines the amount of heat gain through the glass compared to a single lite of clear 1/8" (3 mm) glass. 3) Solar Heat Gain Coefficient (SHGC) defines the fraction of solar radiation admitted through the glass both directly transmitted and absorbed and subsequently released inward. The lower the value, the less heat is transmitted through the glass. 4) Relative Heat Gain is the amount of heat gain through a glazing incorporating U-Factor and Solar Heat Gain Coefficient. 5) Transmission Ultra-Violet Energy (TUV). The transmission of short-wave energy in the 300-380 nanometer portion of the solar spectrum. The energy can cause fabric fading. 6) Transmission Damage Function (TDW). The transmission of UV and visible light energy in the 300-600 nanometer portion of the solar spectrum. The value includes both the UV and visible light energy that can cause fabric fading. This rating has also been referred to as the Krochmann Damage Function. This rating better predicts fading potential than UV transmission alone. The lower the Damage Function rating, the less transmission of short-wave energy through the glass that can potentially cause fabric fading. Fabric type is also a key component of fading potential. 7) Percent relative humidity before condensation occurs at the center of glass, taken using center of glass temperature. 8) Inside glass surface temperatures are taken at the center of glass.  
 • This data is accurate as of October 2019. Due to ongoing product changes, updated test results or new industry standards, this data may change over time. Contact your Andersen supplier for current performance information or upgrade options.  
 • Contact your Andersen supplier or visit [andersenwindows.com/nfrc](http://andersenwindows.com/nfrc) for center of glass performance data on windows with laminated glass, patterned glass, tempered glass and products ordered with capillary breather tubes.

**Center of Glass Performance Data – Low-E4® Sun Impact-Resistant Glass**
*For current performance information, please visit [andersenwindows.com](http://andersenwindows.com).*

Andersen® Product	VT <sup>1</sup>	SC <sup>2</sup>	SHGC <sup>3</sup>	RHG <sup>4</sup>	Fading		%RH @ center <sup>7</sup>	IGST <sup>8</sup>
					Tuv <sup>5</sup>	Tdw <sup>6</sup>		
<b>A-Series Windows</b>								
Casement	38%	0.29	0.25	62	< 1%	14%	57%	54°F
Awning	38%	0.29	0.25	62	< 1%	14%	57%	54°F
Double-Hung	38%	0.29	0.25	62	< 1%	14%	57%	54°F
Stationary Transom	38%	0.29	0.25	62	< 1%	13%	57%	54°F
Venting Transom	38%	0.29	0.25	62	< 1%	14%	57%	54°F
Picture	38%	0.29	0.25	62	< 1%	13%	57%	54°F
Specialty	38%	0.29	0.25	62	< 1%	13%	57%	54°F
<b>A-Series Frenchwood® Patio Doors, Patio Door Transoms &amp; Sidelights and Venting Transom Windows</b>								
Gliding	38%	0.29	0.25	62	< 1%	13%	57%	54°F
Hinged Inswing	38%	0.29	0.25	62	< 1%	13%	57%	54°F
Hinged Outswing	38%	0.29	0.25	62	< 1%	13%	57%	54°F
Transom	38%	0.29	0.25	62	< 1%	11%	57%	54°F
Sidelight	39%	0.29	0.26	63	< 1%	13%	57%	54°F
Venting Transom	39%	0.29	0.26	63	< 1%	13%	57%	54°F

**Center of Glass Performance Data – Clear Monolithic SmartSun™ Impact-Resistant Glass**
*For current performance information, please visit [andersenwindows.com](http://andersenwindows.com).*

Andersen® Product	VT <sup>1</sup>	SC <sup>2</sup>	SHGC <sup>3</sup>	RHG <sup>4</sup>	Fading		%RH @ center <sup>7</sup>	IGST <sup>8</sup>
					Tuv <sup>5</sup>	Tdw <sup>6</sup>		
<b>A-Series Frenchwood® Patio Doors, Patio Door Transoms &amp; Sidelights and Venting Transom Windows</b>								
Gliding	84%	0.82	0.71	176	< 1%	29%	7%	20°F
Hinged Inswing	84%	0.82	0.71	176	< 1%	29%	7%	20°F
Hinged Outswing	84%	0.82	0.71	176	< 1%	29%	7%	20°F
Transom	84%	0.82	0.71	176	< 1%	29%	7%	20°F
Sidelight	84%	0.82	0.71	176	< 1%	29%	7%	20°F

**Center of Glass Performance Data – Gray Monolithic SmartSun™ Impact-Resistant Glass**
*For current performance information, please visit [andersenwindows.com](http://andersenwindows.com).*

Andersen® Product	VT <sup>1</sup>	SC <sup>2</sup>	SHGC <sup>3</sup>	RHG <sup>4</sup>	Fading		%RH @ center <sup>7</sup>	IGST <sup>8</sup>
					Tuv <sup>5</sup>	Tdw <sup>6</sup>		
<b>A-Series Frenchwood® Patio Doors, Patio Door Transoms &amp; Sidelights and Venting Transom Windows</b>								
Gliding	43%	0.67	0.58	146	< 1%	16%	7%	20°F
Hinged Inswing	43%	0.67	0.58	146	< 1%	16%	7%	20°F
Hinged Outswing	43%	0.67	0.58	146	< 1%	16%	7%	20°F
Transom	43%	0.67	0.58	146	< 1%	16%	7%	20°F
Sidelight	43%	0.67	0.58	146	< 1%	16%	7%	20°F

For a listing of helpful links related to performance, test reports and regulations, visit [andersenwindows.com/coastalperformance](http://andersenwindows.com/coastalperformance).

\*Low-E4™, “Low-E4” SmartSun™ and “Low-E4” Sun™ are Andersen trademarks for “Low-E” glass.

\*Based on NFRC testing/simulation conditions using Windows v7.3.4.0 and NFRC validated spectral data. 0°F outside temperature, 70°F inside temperature and a 15 mph wind.

1) Visible Transmittance (VT) measures how much light comes through the glass. The higher the value, from 0 to 1, the more daylight the glass lets in. Visible Transmittance is measured over the 380 to 760 nanometer portion of the solar spectrum. 2) Shading Coefficient defines the amount of heat gain through the glass compared to a single lite of clear 1/8" (3 mm) glass. 3) Solar Heat Gain Coefficient (SHGC) defines the fraction of solar radiation admitted through the glass both directly transmitted and absorbed and subsequently released inward. The lower the value, the less heat is transmitted through the glass. 4) Relative Heat Gain is the amount of heat gain through a glazing incorporating U-Factor and Solar Heat Gain Coefficient. 5) Transmission Ultra-Violet Energy (TUV). The transmission of short-wave energy in the 300-380 nanometer portion of the solar spectrum. The energy can cause fabric fading. 6) Transmission Damage Function (TDW). The transmission of UV and visible light energy in the 300-600 nanometer portion of the solar spectrum. The value includes both the UV and visible light energy that can cause fabric fading. This rating has also been referred to as the Krochmann Damage Function. This rating better predicts fading potential than UV transmission alone. The lower the Damage Function rating, the less transmission of short-wave energy through the glass that can potentially cause fabric fading. Fabric type is also a key component of fading potential. 7) Percent relative humidity before condensation occurs at the center of glass, taken using center of glass temperature. 8) Inside glass surface temperatures are taken at the center of glass.

\*This data is accurate as of October 2019. Due to ongoing product changes, updated test results or new industry standards, this data may change over time. Contact your Andersen supplier for current performance information or upgrade options.

\*Contact your Andersen supplier or visit [andersenwindows.com/nfrc](http://andersenwindows.com/nfrc) for center of glass performance data on windows with laminated glass, patterned glass, tempered glass and products ordered with capillary breather tubes.

**Andersen® NFRC Certified Total Unit Performance**

For current performance information, please visit [andersenwindows.com](http://andersenwindows.com).

Andersen® Product	Impact-Resistant Glass Type	U-Factor <sup>1</sup>	SHGC <sup>2</sup>	VT <sup>3</sup>		
<b>A-Series Casement Windows</b> AND-N-86	Low-E4*	Without Grilles	0.29	0.26	0.45	
		Simulated Divided Light Grilles	0.29	0.24	0.40	
		Finelight™ Light Grilles	0.30	0.24	0.40	
	Low-E4 Sun	Without Grilles	0.26	0.25	0.44	
		Simulated Divided Light Grilles	0.26	0.23	0.39	
		Finelight Light Grilles	0.26	0.23	0.39	
	Low-E4 SmartSun™	Without Grilles	0.29	0.16	0.24	
		Simulated Divided Light Grilles	0.29	0.15	0.22	
		Finelight Light Grilles	0.30	0.15	0.22	
	Low-E4 SmartSun w/HeatLock	Without Grilles	0.28	0.18	0.40	
		Simulated Divided Light Grilles	0.28	0.16	0.36	
		Finelight Light Grilles	0.29	0.16	0.36	
	<b>A-Series Awning Windows</b> AND-N-87	Low-E4*	Without Grilles	0.29	0.26	0.43
			Simulated Divided Light Grilles	0.29	0.23	0.39
			Finelight™ Light Grilles	0.30	0.23	0.39
Low-E4 w/HeatLock		Without Grilles	0.26	0.25	0.42	
		Simulated Divided Light Grilles	0.26	0.23	0.38	
		Finelight Light Grilles	0.26	0.23	0.38	
Low-E4 Sun		Without Grilles	0.29	0.16	0.24	
		Simulated Divided Light Grilles	0.29	0.15	0.21	
		Finelight Light Grilles	0.30	0.15	0.21	
Low-E4 SmartSun™		Without Grilles	0.29	0.18	0.39	
		Simulated Divided Light Grilles	0.29	0.16	0.35	
		Finelight Light Grilles	0.29	0.16	0.35	
Low-E4 SmartSun w/HeatLock		Without Grilles	0.26	0.17	0.38	
		Simulated Divided Light Grilles	0.26	0.16	0.34	
		Finelight Light Grilles	0.26	0.16	0.34	
<b>A-Series Double-Hung Windows</b> AND-N-91	Low-E4*	Without Grilles	0.31	0.30	0.51	
		Simulated Divided Light Grilles	0.31	0.27	0.45	
		Finelight™ Light Grilles	0.31	0.27	0.45	
	Low-E4 w/HeatLock	Without Grilles	0.27	0.29	0.50	
		Simulated Divided Light Grilles	0.27	0.26	0.44	
		Finelight Light Grilles	0.27	0.26	0.44	
	Low-E4 Sun	Without Grilles	0.31	0.19	0.28	
		Simulated Divided Light Grilles	0.31	0.17	0.25	
		Finelight Light Grilles	0.32	0.17	0.25	
	Low-E4 SmartSun™	Without Grilles	0.30	0.20	0.46	
		Simulated Divided Light Grilles	0.30	0.18	0.41	
		Finelight Light Grilles	0.31	0.18	0.41	
	Low-E4 SmartSun w/HeatLock	Without Grilles	0.26	0.20	0.45	
		Simulated Divided Light Grilles	0.26	0.18	0.40	
		Finelight Light Grilles	0.27	0.18	0.40	
	Full Divided Light Grilles	0.28	0.18	0.40		

Andersen® Product	Impact-Resistant Glass Type	U-Factor <sup>1</sup>	SHGC <sup>2</sup>	VT <sup>3</sup>		
<b>A-Series Picture Windows</b> AND-N-88	Low-E4*	Without Grilles	0.29	0.31	0.53	
		Simulated Divided Light Grilles	0.29	0.28	0.47	
		Finelight™ Light Grilles	0.30	0.28	0.47	
	Low-E4 Sun	Without Grilles	0.25	0.30	0.52	
		Simulated Divided Light Grilles	0.25	0.27	0.46	
		Finelight Light Grilles	0.26	0.27	0.46	
	Low-E4 SmartSun™	Without Grilles	0.30	0.19	0.29	
		Simulated Divided Light Grilles	0.30	0.17	0.26	
		Finelight Light Grilles	0.31	0.17	0.26	
	Low-E4 SmartSun w/HeatLock	Without Grilles	0.29	0.21	0.48	
		Simulated Divided Light Grilles	0.29	0.19	0.42	
		Finelight Light Grilles	0.30	0.19	0.42	
	<b>A-Series Fixed Transom Windows</b> AND-N-89	Low-E4*	Without Grilles	0.29	0.31	0.54
			Simulated Divided Light Grilles	0.29	0.28	0.48
			Finelight™ Light Grilles	0.30	0.28	0.48
Low-E4 w/HeatLock		Without Grilles	0.25	0.30	0.53	
		Simulated Divided Light Grilles	0.25	0.27	0.47	
		Finelight Light Grilles	0.26	0.27	0.47	
Low-E4 Sun		Without Grilles	0.30	0.20	0.29	
		Simulated Divided Light Grilles	0.30	0.18	0.26	
		Finelight Light Grilles	0.31	0.18	0.26	
Low-E4 SmartSun™		Without Grilles	0.29	0.21	0.48	
		Simulated Divided Light Grilles	0.29	0.19	0.43	
		Finelight Light Grilles	0.30	0.19	0.43	
Low-E4 SmartSun w/HeatLock		Without Grilles	0.25	0.21	0.47	
		Simulated Divided Light Grilles	0.25	0.19	0.42	
		Finelight Light Grilles	0.26	0.19	0.42	
<b>A-Series Venting Transom Windows</b> AND-N-90	Low-E4*	Without Grilles	0.29	0.27	0.45	
		Simulated Divided Light Grilles	0.29	0.24	0.41	
		Finelight™ Light Grilles	0.30	0.24	0.41	
	Low-E4 w/HeatLock	Without Grilles	0.26	0.26	0.44	
		Simulated Divided Light Grilles	0.26	0.24	0.40	
		Finelight Light Grilles	0.26	0.24	0.40	
	Low-E4 Sun	Without Grilles	0.30	0.17	0.25	
		Simulated Divided Light Grilles	0.30	0.15	0.22	
		Finelight Light Grilles	0.30	0.15	0.22	
	Low-E4 SmartSun™	Without Grilles	0.29	0.18	0.41	
		Simulated Divided Light Grilles	0.29	0.17	0.37	
		Finelight Light Grilles	0.29	0.17	0.37	
	Low-E4 SmartSun w/HeatLock	Without Grilles	0.26	0.18	0.40	
		Simulated Divided Light Grilles	0.26	0.16	0.36	
		Finelight Light Grilles	0.26	0.16	0.36	
	Full Divided Light Grilles	0.27	0.16	0.36		

continued on next page

For a listing of helpful links related to performance, test reports and regulations, visit [andersenwindows.com/coastalperformance](http://andersenwindows.com/coastalperformance).

\*Low-E4™, "Low-E4" SmartSun™, "Low-E4" Sun and HeatLock are Andersen trademarks for "Low-E" glass.  
 1) U-Factor defines the amount of heat loss through the total unit in BTU/hr/ft², °F. The lower the value, the less heat is lost through the entire product. Window values represent non-tempered glass. Use of tempered glass can increase U-Factor ratings. See [andersenwindows.com/nfrc](http://andersenwindows.com/nfrc) for specific performance values. Door values represent tempered glass. 2) Solar Heat Gain Coefficient (SHGC) defines the fraction of solar radiation admitted through the glass both directly transmitted and absorbed and subsequently released inward. The lower the value, the less heat is transmitted through the product. 3) Visible Transmittance (VT) measures how much light comes through a product (glass and frame). The higher the value, from 0 to 1, the more daylight the product lets in over the product's total unit area. Visible Transmittance is measured over the 380 to 760 nanometer portion of the solar spectrum.  
 \* NFRC ratings are based on modeling by a third-party agency as validated by an independent test lab in compliance with NFRC program and procedural requirements.  
 \* This data is accurate as of October 2019. Due to ongoing product changes, updated test results or new industry standards or requirements, this data may change over time. Ratings are for sizes specified by NFRC for testing and certification. Ratings may vary depending on unit size, use of tempered glass, different grille options, glass for high altitudes, etc.  
 \* Values are for single units with given pane thickness and 3/4" (19mm) grilles for windows and 1" (25mm) grilles for door products.



**Andersen® NFRC Certified Total Unit Performance** (continued)  
For current performance information, please visit [andersenwindows.com](http://andersenwindows.com).

Andersen® Product	Impact-Resistant Glass Type	U-Factor <sup>1</sup>	SHGC <sup>2</sup>	VT <sup>3</sup>	
<b>A-Series Direct-Set Specialty Windows</b> ( > 36 sq. ft. to 50 sq. ft. or 3.34 m <sup>2</sup> to 4.65 m <sup>2</sup> ) AND-N-126	Low-E4*	Without Grilles	0.28	0.34	0.56
		Simulated Divided Light Grilles	0.28	0.31	0.51
		Finelight™ Light Grilles	0.30	0.31	0.51
		Full Divided Light Grilles	0.29	0.31	0.51
	Low-E4 w/HeatLock*	Without Grilles	0.24	0.33	0.56
		Simulated Divided Light Grilles	0.24	0.30	0.50
		Finelight Light Grilles	0.25	0.30	0.50
	Low-E4 Sun	Without Grilles	0.29	0.21	0.30
		Simulated Divided Light Grilles	0.29	0.19	0.27
		Finelight Light Grilles	0.29	0.19	0.27
	Low-E4 SmartSun™	Without Grilles	0.28	0.23	0.51
		Simulated Divided Light Grilles	0.28	0.21	0.45
		Finelight Light Grilles	0.28	0.21	0.45
	Low-E4 SmartSun w/HeatLock	Without Grilles	0.23	0.23	0.50
		Simulated Divided Light Grilles	0.23	0.20	0.45
Finelight Light Grilles		0.25	0.20	0.45	
Full Divided Light Grilles		0.25	0.20	0.45	
<b>A-Series Sash-Set Specialty Windows</b> ( > 36 sq. ft. to 50 sq. ft. or 3.34 m <sup>2</sup> to 4.65 m <sup>2</sup> ) AND-N-128	Low-E4*	Without Grilles	0.30	0.31	0.50
		Simulated Divided Light Grilles	0.30	0.27	0.45
		Finelight™ Light Grilles	0.31	0.27	0.45
		Full Divided Light Grilles	-	-	-
	Low-E4 w/HeatLock*	Without Grilles	0.26	0.29	0.50
		Simulated Divided Light Grilles	0.26	0.26	0.44
		Finelight Light Grilles	0.27	0.26	0.44
	Low-E4 Sun	Without Grilles	0.30	0.19	0.27
		Simulated Divided Light Grilles	0.30	0.17	0.24
		Finelight Light Grilles	0.32	0.17	0.24
	Low-E4 SmartSun™	Without Grilles	0.29	0.21	0.45
		Simulated Divided Light Grilles	0.29	0.19	0.40
		Finelight Light Grilles	0.31	0.19	0.40
	Low-E4 SmartSun w/HeatLock	Without Grilles	0.25	0.20	0.47
		Simulated Divided Light Grilles	0.25	0.18	0.40
Finelight Light Grilles		0.27	0.18	0.40	
Full Divided Light Grilles		-	-	-	
<b>A-Series Frenchwood® Gliding Patio Doors</b> AND-N-99	Low-E4*	Without Grilles	0.32	0.26	0.44
		Simulated Divided Light Grilles	0.32	0.23	0.38
		Finelight™ Light Grilles	0.33	0.23	0.38
		Full Divided Light Grilles	0.33	0.23	0.38
	Low-E4 w/HeatLock*	Without Grilles	0.28	0.25	0.43
		Simulated Divided Light Grilles	0.28	0.22	0.37
		Finelight Light Grilles	0.29	0.22	0.37
	Low-E4 Sun	Without Grilles	0.32	0.17	0.24
		Simulated Divided Light Grilles	0.32	0.15	0.21
		Finelight Light Grilles	0.33	0.15	0.21
	Low-E4 SmartSun™	Without Grilles	0.31	0.18	0.40
		Simulated Divided Light Grilles	0.31	0.16	0.34
		Finelight Light Grilles	0.32	0.16	0.34
	Low-E4 SmartSun w/HeatLock	Without Grilles	0.28	0.17	0.39
		Simulated Divided Light Grilles	0.28	0.15	0.33
Finelight Light Grilles		0.29	0.15	0.33	
Full Divided Light Grilles		0.30	0.15	0.33	
Monolithic SmartSun	Clear - Without Grilles	0.71	0.25	0.38	
	Clear - Simulated Divided Light Grilles	0.71	0.22	0.32	
	Gray - Without Grilles	0.71	0.22	0.18	
	Gray - Simulated Divided Light Grille	0.71	0.20	0.16	

Andersen® Product	Impact-Resistant Glass Type	U-Factor <sup>1</sup>	SHGC <sup>2</sup>	VT <sup>3</sup>	
<b>A-Series Frenchwood® Hinged Inswing Patio Doors</b> AND-N-92	Low-E4*	Without Grilles	0.32	0.24	0.40
		Simulated Divided Light Grilles	0.32	0.21	0.34
		Finelight™ Light Grilles	0.33	0.21	0.34
		Full Divided Light Grilles	0.33	0.21	0.34
	Low-E4 w/HeatLock*	Without Grilles	0.29	0.23	0.39
		Simulated Divided Light Grilles	0.29	0.20	0.33
		Finelight Light Grilles	0.30	0.20	0.33
	Low-E4 Sun	Without Grilles	0.32	0.15	0.22
		Simulated Divided Light Grilles	0.32	0.13	0.19
		Finelight Light Grilles	0.33	0.13	0.19
	Low-E4 SmartSun™	Without Grilles	0.33	0.13	0.19
		Full Divided Light Grilles	0.33	0.13	0.19
		Without Grilles	0.32	0.16	0.36
	Low-E4 SmartSun w/HeatLock	Simulated Divided Light Grilles	0.32	0.14	0.31
		Finelight Light Grilles	0.33	0.14	0.31
Full Divided Light Grilles		0.33	0.14	0.31	
Without Grilles		0.28	0.16	0.35	
Monolithic SmartSun	Simulated Divided Light Grilles	0.28	0.14	0.30	
	Finelight Light Grilles	0.29	0.14	0.30	
	Full Divided Light Grilles	0.31	0.14	0.30	
	Clear - Without Grilles	0.67	0.23	0.34	
Low-E4*	Clear - Simulated Divided Light Grilles	0.67	0.20	0.29	
	Gray - Without Grilles	0.67	0.20	0.17	
	Gray - Simulated Divided Light Grille	0.67	0.18	0.14	
<b>A-Series Frenchwood® Hinged Outswing Patio Doors</b> AND-N-93	Low-E4*	Without Grilles	0.32	0.24	0.40
		Simulated Divided Light Grilles	0.32	0.21	0.34
		Finelight™ Light Grilles	0.33	0.21	0.34
		Full Divided Light Grilles	0.33	0.21	0.34
	Low-E4 w/HeatLock*	Without Grilles	0.28	0.23	0.39
		Simulated Divided Light Grilles	0.28	0.20	0.33
		Finelight Light Grilles	0.29	0.20	0.33
	Low-E4 Sun	Without Grilles	0.30	0.20	0.33
		Simulated Divided Light Grilles	0.32	0.15	0.22
		Finelight Light Grilles	0.33	0.13	0.19
	Low-E4 SmartSun™	Without Grilles	0.33	0.13	0.19
		Full Divided Light Grilles	0.33	0.13	0.19
		Without Grilles	0.31	0.17	0.36
	Low-E4 SmartSun w/HeatLock	Simulated Divided Light Grilles	0.31	0.15	0.31
		Finelight Light Grilles	0.32	0.15	0.31
Full Divided Light Grilles		0.32	0.15	0.31	
Without Grilles		0.28	0.16	0.35	
Monolithic SmartSun	Simulated Divided Light Grilles	0.28	0.14	0.30	
	Finelight Light Grilles	0.29	0.14	0.30	
	Full Divided Light Grilles	0.30	0.14	0.30	
	Clear - Without Grilles	0.67	0.23	0.34	
Low-E4*	Clear - Simulated Divided Light Grilles	0.67	0.20	0.29	
	Gray - Without Grilles	0.67	0.21	0.17	
	Gray - Simulated Divided Light Grille	0.67	0.18	0.14	

continued on next page

For a listing of helpful links related to performance, test reports and regulations, visit [andersenwindows.com/coastalperformance](http://andersenwindows.com/coastalperformance).

\* "Low-E4\*", "Low-E4" SmartSun™, "Low-E4" Sun and HeatLock are Andersen trademarks for "Low-E" glass.  
 1) U-Factor defines the amount of heat loss through the total unit in BTU/hr/ft<sup>2</sup>·°F. The lower the value, the less heat is lost through the entire product. Window values represent non-tempered glass. Use of tempered glass can increase U-Factor ratings. See [andersenwindows.com/nfrc](http://andersenwindows.com/nfrc) for specific performance values. Door values represent tempered glass. 2) Solar Heat Gain Coefficient (SHGC) defines the fraction of solar radiation admitted through the glass both directly transmitted and absorbed and subsequently released inward. The lower the value, the less heat is transmitted through the product. 3) Visible Transmittance (VT) measures how much light comes through a product (glass and frame). The higher the value, from 0 to 1, the more daylight the product lets in over the product's total unit area. Visible Transmittance is measured over the 380 to 760 nanometer portion of the solar spectrum.  
 • NFRC ratings are based on modeling by a third-party agency as validated by an independent test lab in compliance with NFRC program and procedural requirements.  
 • This data is accurate as of October 2019. Due to ongoing product changes, updated test results or new industry standards or requirements, this data may change over time. Ratings are for sizes specified by NFRC for testing and certification. Ratings may vary depending on unit size, use of tempered glass, different grille options, glass for high altitudes, etc.  
 • Values are for single units with given pane thickness and 3/4" (19mm) grilles for windows and 1" (25mm) grilles for door products.

Combination Designs,  
Product Performance  
& Installation

**Andersen® NFRC Certified Total Unit Performance** (continued)  
 For current performance information, please visit [andersenwindows.com](http://andersenwindows.com).

Andersen® Product	Impact-Resistant Glass Type	U-Factor <sup>1</sup>	SHGC <sup>2</sup>	VT <sup>3</sup>	
<b>A-Series Frenchwood® Patio Door Sash-Set Transoms &amp; Sidelight Transoms</b> AND-N-95	Low-E4*	Without Grilles	0.31	0.25	0.42
		Simulated Divided Light Grilles	0.31	0.23	0.38
		Finelight™ Light Grilles	0.32	0.23	0.38
		Full Divided Light Grilles	0.32	0.23	0.38
	Low-E4 w/HeatLock®	Without Grilles	0.28	0.25	0.42
		Simulated Divided Light Grilles	0.28	0.22	0.37
		Finelight Light Grilles	0.28	0.22	0.37
		Full Divided Light Grilles	0.29	0.22	0.37
	Low-E4 Sun	Without Grilles	0.32	0.16	0.23
		Simulated Divided Light Grilles	0.32	0.15	0.21
		Finelight Light Grilles	0.32	0.15	0.21
		Full Divided Light Grilles	0.32	0.15	0.21
	Low-E4 SmartSun™	Without Grilles	0.31	0.17	0.38
		Simulated Divided Light Grilles	0.31	0.16	0.34
		Finelight Light Grilles	0.31	0.16	0.34
		Full Divided Light Grilles	0.31	0.16	0.34
	Low-E4 SmartSun w/HeatLock	Without Grilles	0.28	0.17	0.37
		Simulated Divided Light Grilles	0.28	0.15	0.33
		Finelight Light Grilles	0.28	0.15	0.33
		Full Divided Light Grilles	0.29	0.15	0.33
	Monolithic SmartSun	Clear - Without Grilles	0.70	0.23	0.35
		Clear - Simulated Divided Light Grilles	0.70	0.21	0.31
		Gray - Without Grilles	0.70	0.21	0.17
		Gray - Simulated Divided Light Grille	0.70	0.19	0.15
<b>A-Series Frenchwood® Patio Door Direct-Set Transoms &amp; Sidelight Transoms</b> AND-N-96	Low-E4*	Without Grilles	0.30	0.33	0.57
		Simulated Divided Light Grilles	0.30	0.30	0.51
		Finelight™ Light Grilles	0.31	0.30	0.51
		Full Divided Light Grilles	0.31	0.30	0.51
	Low-E4 w/HeatLock®	Without Grilles	0.26	0.32	0.56
		Simulated Divided Light Grilles	0.26	0.29	0.50
		Finelight Light Grilles	0.26	0.29	0.50
		Full Divided Light Grilles	0.28	0.29	0.50
	Low-E4 Sun	Without Grilles	0.31	0.21	0.31
		Simulated Divided Light Grilles	0.31	0.19	0.28
		Finelight Light Grilles	0.31	0.19	0.28
		Full Divided Light Grilles	0.31	0.19	0.28
	Low-E4 SmartSun™	Without Grilles	0.30	0.23	0.51
		Simulated Divided Light Grilles	0.30	0.21	0.46
		Finelight Light Grilles	0.30	0.21	0.46
		Full Divided Light Grilles	0.30	0.21	0.46
	Low-E4 SmartSun w/HeatLock	Without Grilles	0.26	0.22	0.50
		Simulated Divided Light Grilles	0.26	0.20	0.45
		Finelight Light Grilles	0.26	0.20	0.45
		Full Divided Light Grilles	0.27	0.20	0.45
	Monolithic SmartSun	Clear - Without Grilles	0.84	0.32	0.49
		Clear - Simulated Divided Light Grilles	0.84	0.29	0.44
		Gray - Without Grilles	0.84	0.28	0.24
		Gray - Simulated Divided Light Grille	0.84	0.26	0.21
<b>A-Series Frenchwood® Patio Door Sidelights</b> AND-N-94	Low-E4*	Without Grilles	0.31	0.23	0.37
		Simulated Divided Light Grilles	0.31	0.20	0.33
		Finelight™ Light Grilles	0.32	0.20	0.33
		Full Divided Light Grilles	0.32	0.20	0.33
	Low-E4 w/HeatLock®	Without Grilles	0.28	0.22	0.37
		Simulated Divided Light Grilles	0.28	0.20	0.33
		Finelight Light Grilles	0.29	0.20	0.33
		Full Divided Light Grilles	0.30	0.20	0.33
	Low-E4 Sun	Without Grilles	0.32	0.14	0.20
		Simulated Divided Light Grilles	0.32	0.13	0.18
		Finelight Light Grilles	0.33	0.13	0.18
		Full Divided Light Grilles	0.32	0.13	0.18
	Low-E4 SmartSun™	Without Grilles	0.31	0.16	0.34
		Simulated Divided Light Grilles	0.31	0.14	0.30
		Finelight Light Grilles	0.32	0.14	0.30
		Full Divided Light Grilles	0.32	0.14	0.30
	Low-E4 SmartSun w/HeatLock	Without Grilles	0.28	0.15	0.33
		Simulated Divided Light Grilles	0.28	0.14	0.29
		Finelight Light Grilles	0.29	0.14	0.29
		Full Divided Light Grilles	0.30	0.14	0.29
	Monolithic SmartSun	Clear - Without Grilles	0.65	0.22	0.32
		Clear - Simulated Divided Light Grilles	0.65	0.19	0.28
		Gray - Without Grilles	0.65	0.19	0.16
		Gray - Simulated Divided Light Grille	0.65	0.17	0.14

For a listing of helpful links related to performance, test reports and regulations, visit [andersenwindows.com/coastalperformance](http://andersenwindows.com/coastalperformance).

\*“Low-E4”, “Low-E4 SmartSun”, “Low-E4 Sun” and HeatLock® are Andersen trademarks for “Low-E” glass.  
 1) U-Factor defines the amount of heat loss through the total unit in BTU/hr/ft²·°F. The lower the value, the less heat is lost through the entire product. Window values represent non-tempered glass. Use of tempered glass can increase U-Factor ratings. See [andersenwindows.com/nfrc](http://andersenwindows.com/nfrc) for specific performance values. Door values represent tempered glass. 2) Solar Heat Gain Coefficient (SHGC) defines the fraction of solar radiation admitted through the glass both directly transmitted and absorbed and subsequently released inward. The lower the value, the less heat is transmitted through the product. 3) Visible Transmittance (VT) measures how much light comes through a product (glass and frame). The higher the value, from 0 to 1, the more daylight the product lets in over the product’s total unit area. Visible Transmittance is measured over the 380 to 760 nanometer portion of the solar spectrum.  
 • NFRC ratings are based on modeling by a third-party agency as validated by an independent test lab in compliance with NFRC program and procedural requirements.  
 • This data is accurate as of October 2019. Due to ongoing product changes, updated test results or new industry standards or requirements, this data may change over time. Ratings are for sizes specified by NFRC for testing and certification. Ratings may vary depending on unit size, use of tempered glass, different grille options, glass for high altitudes, etc.  
 • Values are for single units with given pane thickness and 3/4" (19mm) grilles for windows and 1" (25mm) grilles for door products.

**About the NFRC**

The National Fenestration Rating Council (NFRC) is a nonpartisan coalition of professionals whose purpose is to provide fair, accurate and credible energy performance ratings for fenestration products. NFRC's membership includes manufacturers, suppliers, designers, specifiers, utility companies, government agencies and other building industry representatives.

Andersen Corporation is a founding member of the NFRC and continues to support its work by providing fair, accurate and credible energy performance ratings to consumers and the building industry. If you have any questions about the NFRC, its program or energy performance ratings, write them at: NFRC, 6305 Ivy Lane, Suite 140, Greenbelt, MD 20770 Tel: (301) 589-1776 Website: [www.nfrc.org](http://www.nfrc.org)

**About the Label**

Look for this certification label on every window and patio door you buy. The NFRC section was designed by the National Fenestration Rating Council to provide accurate information that helps you promote the energy efficiency of the homes you build. These ratings allow you – and your customers – to measure and compare the energy performance of similar products. If the product does not have this label, the NFRC has not verified its claims.

**U-Factor** indicates how well a product prevents heat from escaping (the lower the number, the better).

**Visible Transmittance** refers to how much visible light comes through a product (the closer to 1.0, the more light is transmitted).

**WDMA Hallmark Certification** verifies the performance ratings of this product were tested by a third-party testing laboratory.

**Test Standards**

**Florida Product Approval Number, Miami-Dade County Notice of Acceptance (NOA) Number or Texas Department of Insurance (TDI) Number**

Do not remove until final code inspection. Save label for future reference.

**ENERGY STAR® Certified in Highlighted Regions**  
Certifié ENERGY STAR dans les régions en surbrillance

Canada  
energystar.gc.ca

ENERGY STAR

U.S. / É.U.  
energystar.gov

ER/RE 19

DO NOT REMOVE UNTIL FINAL INSPECTION / NE PAS RETIRER AVANT L'INSPECTION FINALE

NFRC  
National Fenestration Rating Council®  
CERTIFIED

Andersen® AW

**A-Series Casement Window**  
AND-N-86-02820-0004  
Composite/Wood Combination, Dual-Pane Low-E SmartSun HeatLock Impact Resistant with Argon  
Product Type: Casement

**ENERGY PERFORMANCE RATINGS**

U-Factor <b>0.25</b> (U.S./I-P)	Solar Heat Gain Coefficient <b>0.17</b>
Visible Transmittance <b>0.39</b>	

Manufacturer stipulates that these ratings conform to applicable NFRC procedures for determining whole product performance. NFRC ratings are determined for a fixed set of environmental conditions and a specific product size. NFRC does not recommend any product and does not warrant the suitability of any product for any specific use. Consult manufacturer's literature for other product performance information.  
[www.nfrc.org](http://www.nfrc.org)

WDMA  
Hallmark Certified  
www.wdma.com

Licensee: 129-H-955  
Andersen Corporation  
**A-Series Casement Window with Stormwatch Protection**  
Manufacturer stipulates Hallmark Certification as indicated below.

STANDARD	RATING
AAMA/WDMA/CSA 101/I.S.2/A440-11	Class LC-PG70 Size Tested 35.3" x 71.3" DP+70/-70
AAMA/WDMA/CSA 101/I.S.2/A440-08	Class LC-PG70 Size Tested 35.3" x 71.3" DP+70/-70
AAMA/WDMA/CSA 101/I.S.2/A440-08 A440S1-09	Class LC-PG70 Size Tested 895 x 1803 mm DP-3360/-3360 Pa Water Penetration Resistance Test Pressure = 510 Pa Canadian Air Infil/Exfil = A3
ASTM E1886/E1996	DP+70/-70 psf, Missile D, Wind Zone 4
FL 15551	

Glazing: 3.9mm AN outer/7.6mm LG (2.7mm AN/2.7mm AN) inner

**WARNING**  
This product can expose you to chemicals including titanium dioxide, which is known in the state of California to cause cancer, and methanol, which is known to the state of California to cause birth defects or other reproductive harm. For more information go to [www.P65Warnings.ca.gov](http://www.P65Warnings.ca.gov)

Meets or exceeds CEC & IECC Air Infiltration Requirements of 0.2 CFM/sq.ft. or lower.  
WDMA Hallmark Certification Program. Complies with HUD UM Bulletin No. 111.

**Energy Rating (ER)** represents "Energy Rating" and is a rating used in Canada for product comparison purposes (the higher the ER number, the more energy saved during the heating season).

**ENERGY STAR® Climate Zone Map** is based on U-Factor and solar heat gain coefficient criteria for specific ENERGY STAR climate zones within the United States and Canada. The shading of the map shows which climate zone(s) a particular product and glass type is ENERGY STAR certified in.

**Solar Heat Gain Coefficient** measures how well a product blocks heat caused by sunlight (the lower the number, the more it will help reduce the use of air conditioning and as a result, reduce electrical bills and energy use).

**Performance Grade (PG) and Design Pressure (DP) Ratings**

**Impact-Resistant Glass Construction**

\* NFRC ratings are based on modeling by a third-party agency as validated by an independent test lab in compliance with NFRC program and procedural requirements.

Listed are optional accessories available for the installation of Andersen® windows and doors. You'll also find key considerations regarding the use and installation of every Andersen product. Keep the instruction guidelines and safety information in mind when considering the installation and use of any Andersen product. Should you have any questions, contact your local Andersen supplier. Thank you for considering and using Andersen products.

## COIL STOCK

Andersen aluminum coil stock can be ordered to match any of our 11 exterior trim colors. Made from .018" thick aluminum, coil stock is available in 24" (610) x 50' (15240) rolls. Color-matched 1 1/4" (32) stainless steel trim nails are also available and can be ordered in 1 lb./454 kg boxes.



## FIBREX® TRIM BOARD



Andersen offers a 3 1/2" (89) wide by 3/4" (19) thick cellular Fibrex trim board in 10' (3048) lengths. Available in the same 11 colors as the exterior trim system, this solid trim board can be cut or ripped to size and can be fastened using nails or screws.

## EXTENSION JAMBS

Available for most Andersen products. See sections for details.

## DRIP CAP



Included on A-Series windows with vertical (ribbon) joins. Heavy 24-gauge corrosion-resistant aluminum construction. Available in 6' (1829), 10' (3048) and 12'-7 1/2" (3848) lengths and in any of the 11 exterior trim colors.

## COLOR-MATCHED SEALANT

Color-matched sealant is available in Andersen exterior colors. This high-quality sealant can be used during the installation of all Andersen products.

## VINYL CHANNELS



Rigid vinyl "J" & "h" channels are available in white, Sandtone and Terratone. "J" & "h" channels are 1/2" (13) deep and come in 150" (3810) lengths. "J" channels are 3/4" (19) wide and "h" channels are 1" (25) wide. "H" channels are 3/4" (19) deep and come in 84" (2134) and 150" (3810) lengths. White Sandtone and Terratone "H" channels are 1" (25) wide.

# INSTALLATION INFORMATION

## ROUGH OPENINGS

The purpose of a rough opening is to allow for proper spacing between the window or patio door unit and the building structure. The space is required for locating, leveling and squaring the unit during installation and to provide an area for insulation. A rough opening that is incorrectly sized may affect unit operation and may not allow for adequate fastening of the unit to the building structure. Andersen rough opening dimensions are provided as a guideline to help determine the minimum amount of space needed between the window or patio door and the building structure. See appropriate product sections for rough opening guidelines for each product.

Keep in mind that rough opening dimensions may need to be altered from published guidelines, depending on installation methods, joining methods, replacement methods, etc. For example, flashing systems can reduce the amount of available rough opening space and should be factored in when calculating rough opening dimensions. The use of support or joining materials will encroach on the rough opening and may require additional rough opening space between the unit and the building structure, depending on the thickness of the flashing system and joining materials used. To facilitate drainage, the rough opening sill plate should never slope toward the interior. For challenging environments and other information, refer to EEBA's (Energy and Environmental Building Association) Water Management Guide ([www.eeba.org](http://www.eeba.org)).

## IMPORTANCE OF PROPER INSTALLATION

Proper installation and maintenance of Andersen products is essential to attain optimum performance and operation. Installation instructions that provide guidelines for proper installation are typically provided with Andersen products. They are also available by visiting [andersenwindows.com](http://andersenwindows.com). Remember that every installation is different, and Andersen strongly recommends consultation with the local supplier or an experienced contractor, architect or structural engineer prior to the installation of any Andersen product. The method of attachment for Andersen products, fastener selection and code compliance is the responsibility of the architect, building owner, contractor, installer and/or consumer. For more complete installation details, visit [andersenwindows.com](http://andersenwindows.com) or see your Andersen supplier.

## GENERAL NOTES

When ordering, make certain you specify, then verify, the exact product, unit dimensions, configuration requirements, color and options you desire on each window or patio door. Before installing the product, we suggest you verify that it includes the features and options you ordered. Visit [andersenwindows.com](http://andersenwindows.com) for product installation and joining guides. Printing limitations prohibit exact color duplication of products. View actual samples for building specifications. Andersen Corporation reserves the right to change details, specifications or sizes without notice. The customer assumes all risk of alterations made to Andersen products.

Dimensions in parentheses are in millimeters.

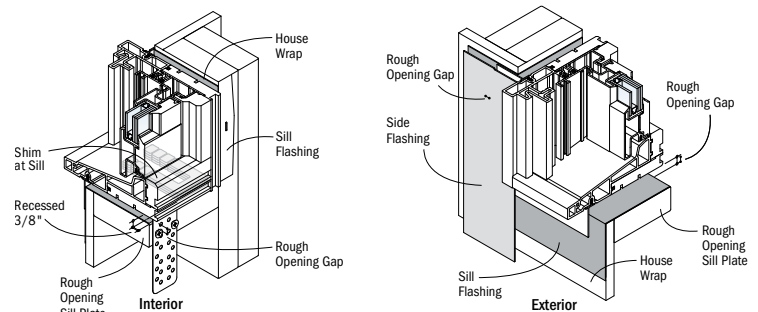

Example of window sill flashing in a membrane drainage system.

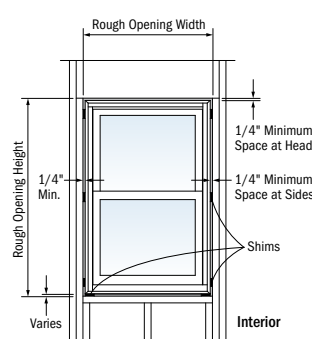

Example of window unit installed using Andersen published minimum rough opening dimensions.

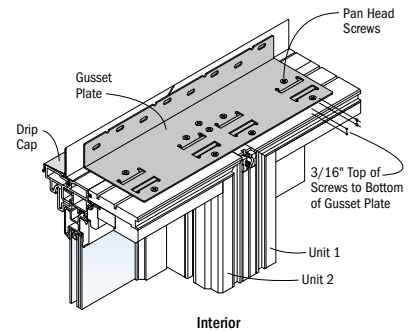

Example of two units joined together with the use of gusset plates and pan head screws that will require additional rough opening space.

## CODES

Appropriate selection of Andersen products that conform to all applicable laws, ordinances, building codes and safety requirements is the sole responsibility of the architect, designer, building owner and/or contractor. Check with your local building code officials for specific information. Unit wind load, performance grade and energy performance information is provided on pages 148-169. For up-to-date product performance information, visit [andersenwindows.com](http://andersenwindows.com). The performance of any building system depends on the design and construction of the building system in its entirety, which should meet building code requirements, as well as address product and material limitations and local environment and climate.

## DRIP CAPS

Drip caps are a specific type of flashing or trim that is used at the head of a window or door to direct water from the drainage plane out beyond the face of the unit.

## FLASHING

Flashing is an important element in a building's water management system. It is used to shed and direct water to the building exterior or to the drainage plane. Flashing materials are typically applied starting from the bottom and working upward, with each successive layer overlapping the previous one in shingle fashion. Water infiltration problems in any type of building can be reduced by properly flashing and/or sealing around all building openings, including windows and doors.

## USE OF SHIMS

Shims are used along the side jambs of windows and doors to center the unit in the rough opening and to position it plumb, level and square. In addition, shims are always required for windows under the sill at the side jambs to lift it off the rough opening sill plate. Shims also enable a straight frame for proper weatherstrip contact and unit operation. If not placed properly, unit performance and operation can be affected. Use waterproof shims capable of supporting the weight of the product. When using tapered shims, use them in pairs with the tapers opposing each other to avoid tilting the unit or twisting (rotating) of the jambs.

## SEALANTS

Sealants are elastic materials used to block the passage of water and/or air while allowing movement between the two sides of the joint. A sealant should bond tightly and be able to expand and contract to accommodate joint movement without cracking or tearing away from the substrate. Surfaces must be clean, dry and sound for adequate sealant adhesion. Choose a sealant that is compatible with, and that will adhere adequately to, all building materials used in the window and patio door area. Proper sealant joint design is based upon the expected movement of adjacent materials and the movement capability of the sealant. A general rule of thumb is that the depth of the sealant joint should be equal to half the width ( $D = W/2$ ), but generally not less than 1/4" (6) or more than 1/2" (13). Foam-plastic backer rod can be used to limit the depth of the sealant joint, to provide a backstop for tooling the sealant without damage to the bond. It also acts as a bond breaker to help minimize stress in the sealant. Sealants should be maintained seasonally and repaired and/or replaced as needed.

## GENERAL INSTALLATION GUIDELINES

1. Read and follow the installation guide in its entirety.
2. Decide whether you are integrating to a surface barrier or a membrane drainage system before installing the product. The appropriate method for your installation may vary based on building design, application and industry practices.
3. Make certain the drainage plane is continuous (proper overlaps to shed water, taped seams, etc.).
4. Andersen products should be installed only in the vertical position.
5. Check the rough opening to make sure it is sized properly, is square and is level.
6. Install the window or door plumb.

Dimensions in parentheses are in millimeters.

7. Install the window or door level.
8. Install the window or door square. Diagonal measurements should be within 1/8" (3).
9. Follow installation instructions to properly locate shims and to make sure that units are plumb, level and square. Shims are always required under the window jambs at the sill and along the jambs on the sides.
10. Check for squareness of unit before final anchoring of the product into the wall.
11. Anchor window as directed with appropriate fasteners.
12. Integrate the window into the drainage plane of the wall using quality flashing and sealing materials. All flashing materials should be properly overlapped to shed water.
13. Allow 1/4" (6) minimum space for a sealant joint around perimeter of unit between exterior finish materials and unit.
14. Insulate and seal the interior cavity between the window or door frame and the rough opening.
15. Check unit operation before application of interior trim.
16. Stain and/or seal all unfinished wood surfaces promptly to minimize moisture absorption.

## EXTERIOR PAINTING/SEALING OF ANDERSEN® PRODUCTS

The exterior of some Andersen products may be painted or stained. However, improper painting and staining may cause damage to vinyl, aluminum and other exterior materials.

## CAUTIONS

1. Do not apply any type of film to insulating glass. Thermal stress and glass damage can result. Andersen Corporation is not responsible for product performance when films are applied to Andersen products.
2. The use of removable insulating materials such as insulated window coverings, shutters and other shading devices may also cause thermal stress conditions and/or deformation of protective vinyl. In addition, excessive condensation may result, which can have a deteriorating effect on the window or patio door unit(s) involved. Andersen Corporation is not responsible for product performance when these kinds of materials or devices are applied to or used in conjunction with Andersen products.
3. In wall construction utilizing brick facades, leave adequate clearance between sill, jambs and brick for sealing and dimensional change of framework.
4. Acid solutions commonly used to wash brick and other masonry materials will damage glass, fasteners, hardware and metal flashing. Protect unit and follow cleaning product instructions carefully. Damage caused by acid solution is not covered under the Andersen limited warranty.
5. Andersen windows may be combined in almost unlimited ribbons or stacks if each unit is positively secured to structural elements on opposing sides and if the proper joining system is used. See page 148 for more information.

## SAFETY GLASS

Unless specifically ordered, Andersen windows with Low-E4 impact-resistant glass are not made with safety glass on the outside light, and, if broken, the glass could fragment, causing injury. Andersen windows may be ordered with tempered glass which may reduce the

likelihood of injury when broken. All Andersen patio doors are made with tempered glass. Differences in appearance between tempered and non-tempered glass can be expected. Slight visual distortions may be noticeable and occur normally as a result of the tempering process. Building codes require safety glass in locations adjacent to or near doors and other locations.

## IMPACT-RESISTANT GLASS UNITS NOTICE

Please note that Andersen® Stormwatch® products with impact-resistant glass are not hurricane- or shatter-proof. However, Andersen products with Stormwatch protection glazed with impact-resistant glass are less susceptible to object penetration when broken than units glazed with other types of glass. Coastal products are tested to the impact performance requirements of the large missile test of ASTM E1996/E1886 and/or TAS 201, 202, 203. Coastal products with impact-resistant glass have been tested for air, water and structural performance based on the requirements of a specific product performance rating. However, when these units are subjected to intense storms or extreme conditions, which exceed the intended product performance rating, air and water infiltration and flying debris penetration may occur.

In the event of an intense storm or extreme weather conditions, **do not** stand in front of windows and doors. Make sure all windows and doors are closed, locked and any auxiliary hardware (tilt-wash retractable brackets) are engaged. Remove all window and door accessories such as grilles, art glass panels and insect screens. Seek safety at approved evacuation locations. If none are available, follow your community's predetermined evacuation route to a safe location.

## WINDOW AND PATIO DOOR SAFETY

Windows may provide a secondary avenue of escape or rescue in an emergency, such as a fire. Every family should develop an escape plan and make sure family members know how to escape from the home in an emergency. In your plan, include two ways to escape from every room in case one way is blocked by fire or smoke, and make sure you have a designated meeting place outside. A window or a door is an alternate means of escape or rescue. Practice your plan until each member of the family understands it and is able to escape without assistance. Remember, you may not be able to reach children during a fire emergency. Teach children – even very young children – that they must escape from a fire in the home and never hide from the fire or from emergency personnel.

## LOOKOUT FOR KIDS® PROGRAM

The Consumer Product Safety Commission has said: "Keep children away from open windows to prevent falls. Don't depend on insect screens to keep the child from falling out of the window. They are designed to keep insects out, not children in. Avoid placing furniture near windows to keep children from climbing to a window seat or sill." In an effort to educate consumers about the potential for child falls from windows, Andersen Corporation created the LookOut For Kids Program. It combines a window and door safety brochure and specific product instructions to help make window and door safety an important priority for consumers. For more information on child safety, write:

Andersen Corporation  
**LookOut For Kids Program**  
 100 Fourth Avenue North  
 Bayport, MN 55003  
 1-800-313-8889  
[lofk@andersencorp.com](mailto:lofk@andersencorp.com)



# Andersen® windows and patio doors can make significant contributions to the success of sustainable design strategies

As a charter member of the U.S. Green Building Council, we are active supporters of certified green buildings. Our products can help customers in pursuing green building programs, such as Leadership in Energy and Environmental Design (LEED®), the National Green Building Standard, Green Globes, GreenStar and more. Below is an overview of how our products may assist project teams with pursuing LEED v4 or the NAHB National Green Building Standard rating systems. More detailed credit summaries, as well as information about how Andersen products can support earlier versions of LEED certification (e.g., LEED v3 or LEED 2008), are available at [andersenwindows.com](http://andersenwindows.com).

## LEED V4 FOR BUILDING DESIGN AND CONSTRUCTION: NEW CONSTRUCTION AND MAJOR RENOVATIONS

### Integrative Process Credit:

#### Energy & Atmosphere

- Minimum energy performance prerequisite
- Optimize energy performance credit
- Renewable energy production credit
- Green power and carbon offsets credit

#### Materials & Resources

- Construction and demolition waste management planning credit
- Building product disclosure and optimization sourcing of raw materials credit
- Construction and demolition waste management credit

#### Indoor Environmental Quality

- Minimum indoor air quality performance prerequisite
- Minimum acoustic performance prerequisite – schools
- Enhanced indoor air quality strategies credit
- Low-emitting materials credit
- Thermal comfort credit
- Daylight credit
- Quality views credit
- Acoustic performance credit (option 2)

## LEED V4 FOR BUILDING DESIGN AND CONSTRUCTION: HOMES AND MULTI-FAMILY MIDRISES

### Energy & Atmosphere

- Minimum energy performance prerequisite
- Education of the homeowner, tenant or building prerequisite
- Annual energy use credit
- Building orientation for passive solar credit
- Air infiltration credit
- Windows credit

### Materials & Resources

- Durability management prerequisite
- Environmentally preferable products credit
- Construction waste management credit

### Indoor Environmental Quality

- Ventilation prerequisite
- Low-emitting products credit

## ANSI ICC/ASHRAE 700-2015 NATIONAL GREEN BUILDING STANDARD

NGBS section numbers are referenced in parentheses.

### Resource Efficiency

- Prefinished materials (601.7)
- Flashing (602.12)
- Exterior doors, including storm doors (602.1.10)
- Recycled construction materials (605.3)
- Bio-based products (606.1)
- Wood-based products (606.2)
- Manufacturer's environmental management system concepts (611.1)

### Energy Efficiency

- Mandatory requirements (701.1)
- Building thermal envelope air sealing (701.4.3.1)
- Multi-family air leakage alternative (701.4.3.3)
- Fenestration air leakage (701.4.3.4)
- ICC IECC analysis (702.2.1)
- Energy performance analysis (702.2.2)
- UA improvement (703.2.1)
- Fenestration (703.2.5)
- Sun-tempered design (703.7.1)
- Passive cooling design (703.7.3)
- Passive solar heating design (703.7.4)

### Indoor Environmental Quality

- Wood materials (901.4)
- Interior architectural coatings (901.9)
- Interior adhesives & sealants (901.9)
- Operable windows & sliding glass doors (902.1.5)

### Energy Efficient

- Homeowner's manual (1001.1)
- Building construction manual (1002.1)



## THE ENVIRONMENT HAS A BUSINESS PARTNER

Respect for the environment is nothing new at Andersen. For more than a century, it's been part of who we are. Our commitment to recycle and reclaim materials began simply because it was good business. Now it's part of our broader commitment to sustainability and responsible stewardship of all our resources. Andersen is committed to providing you with long-lasting,\* energy-efficient windows and patio doors. Visit [andersenwindows.com/sustainability](http://andersenwindows.com/sustainability) for more information.



Andersen products are certified under the National Fenestration Rating Council's voluntary third-party certification program designed to ensure accurate energy performance ratings and labeling.



Andersen was one of the first U.S. window manufacturers to receive the Forest Stewardship Council® (FSC®) Chain-of-Custody certification (FSC® C016636). This certification is awarded to companies that meet FSC standards for traceability in their wood supply chain.



The Window & Door Manufacturers Association (WDMA) Hallmark Certification program includes product testing and quality-control process audits to verify that Andersen® windows and doors are produced in conformance with the industry standards for air, water resistance and structural performance.



Andersen Corporation is proud to be an ENERGY STAR® partner. For over 115 years, Andersen has built a reputation for environmental stewardship and energy-efficient products. In fact, Andersen has been part of the ENERGY STAR program since it started and was the first window manufacturer to be named an ENERGY STAR National Window Partner of the Year in 1999.

\*Visit [andersenwindows.com/warranty](http://andersenwindows.com/warranty) for details.

All logos and marks are trademarks of their respective owners.

63 A-Series Specialty Windows	141 Exterior Trim	60 A-Series Window Custom Sizes	57 A-Series Window Joining Details	50 A-Series Transom Windows	42 A-Series Picture Windows	36 A-Series Double-Hung Windows	24 A-Series Casement & Awning Windows	19 A-Series Window Overview
141 Exterior Trim	139 A-Series Frenchwood® Patio Door Custom Sizes	136 A-Series Frenchwood® Patio Door Joining Details	128 A-Series Frenchwood® Patio Door Sidelights & Transoms	121 A-Series Frenchwood® Hinged Outswing Patio Doors	114 A-Series Frenchwood® Hinged Inswing Patio Doors	110 A-Series Frenchwood® Gliding Patio Doors	103 A-Series Frenchwood® Patio Door Overview	150 Combination Designs, Product Performance & Installation



All trademarks where denoted are marks of their respective owners.  
©2020 Andersen Corporation. All rights reserved. 03/20 Part #110010





# PDF NAVIGATION TIPS

Welcome to an overview of the enhanced navigation tools available in this PDF. Here are some simple tips on PDF navigation. Before you begin be sure you are using the latest version of Adobe Acrobat Reader DC, available at - <https://get.adobe.com/reader/>

To watch a 3-minute tutorial on navigating catalog PDFs, go to: <https://youtu.be/sWWnYn6ON3Y>

## BOOKMARK NAVIGATION

①

Acrobat will display the bookmarks panel when you open the PDF.

**Bookmarks** are the easiest way to find specific product information.

Select a topic and that page will be displayed.

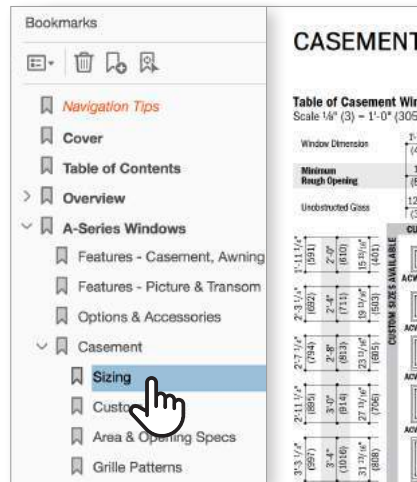

②

If you need to print a specific section, **right click on that section** within in the bookmarks panel and choose “**Print Section.**”

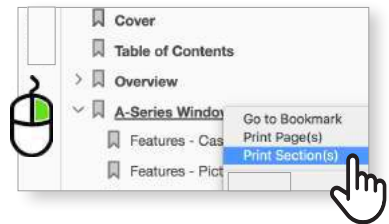

## LINKS AND URL NAVIGATION

①

You can also use the **embedded links** to navigate between sections. All links are underlined in blue.

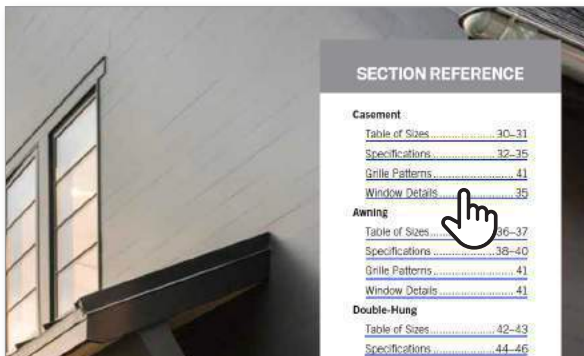

②

Website links automatically open in your web browser.



