

# build<sup>1</sup><sub>0</sub> SCIENCE™ <sup>1</sup><sub>1</sub>

Integration Not Application

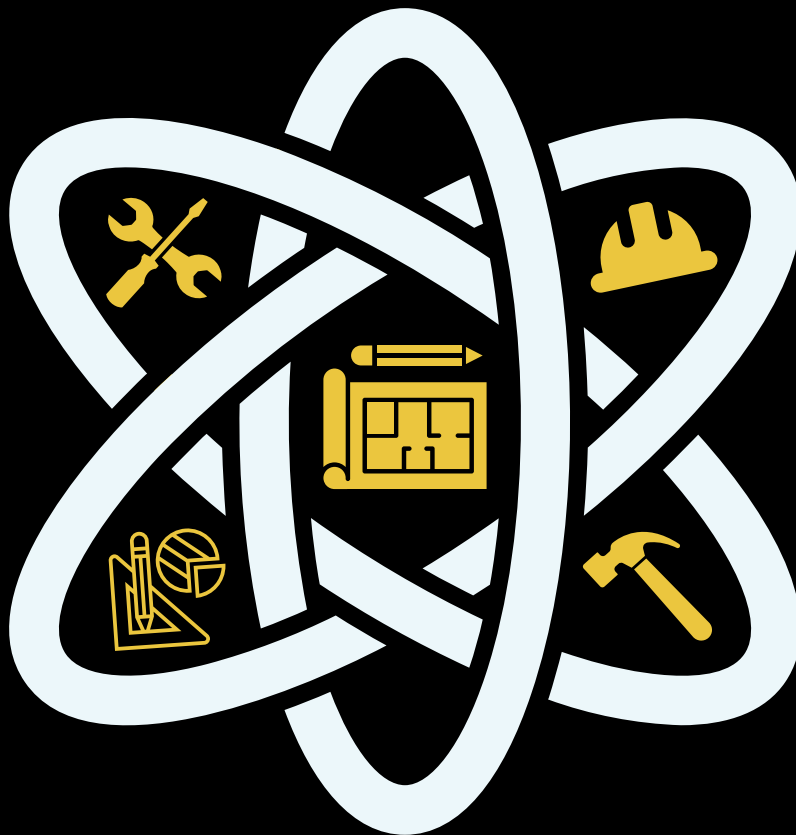

S E R I E S   U N D E R W R I T E R

---



# Welcome to Build Science™ 101

We're building professionals. We're the folks who take a vision and turn it into someone's dream home, office, or any other structure. Precision, accuracy, and control - it's in our DNA. We've mastered our trades, dominated site logistics, and handled every crisis thrown our way. But when it comes to truly understanding and harnessing the science behind our buildings, are we giving it the same precision we'd give to mitered joints? This is our wake-up call to dive deeper, and not just build, but build with a profound understanding of the spaces we create. It's time to graduate from good to great. Know Better, Build Better!

Enter building science, a combination of engineering, architecture, chemistry, and even physics, joining forces to shape our buildings into masterpieces of both form and function. This isn't just about pretty structures. We dive deep into understanding energy efficiency, achieving ultimate comfort, safeguarding our health, and ensuring our spaces last.

In this 10-part series, we take a hard look at building science concepts—by determining what it is and isn't. We concentrate on the four fundamental layers of building science—water management, air tightness, vapor management, and thermal management. After taking this series, you'll have answers to some basic questions, such as:

- Do buildings need to “breathe?” (Hint—No)
- Why is vapor management so mysterious?
- How might the R-values we use fall short of what building codes require?
- What is the number one killer of buildings, and also responsible for 80% of post-build litigation?
- Should we implement building science or, instead, change our building philosophy?
- Why does that old church in the middle of nowhere outlast some of our modern buildings that crumble within decades?
- How has insulation disrupted traditional building methods and pushed us to rethink how we build?

## CONTENTS

<b>CH. 1</b>	<b>WHY DO WE BUILD? . . . . .</b>	<b>4</b>
<b>CH. 2</b>	<b>THE BUILD SCIENCE™ BEHIND DURABILITY. . . . .</b>	<b>8</b>
<b>CH. 3</b>	<b>THE BUILD SCIENCE™ BEHIND COMFORT AND HEALTH . . . . .</b>	<b>12</b>
<b>CH. 4</b>	<b>ENERGY EFFICIENCY AND ENVIRONMENTAL RESPONSIBILITY. . . . .</b>	<b>17</b>
<b>CH. 5</b>	<b>WHERE IS BUILDING SCIENCE? . . . . .</b>	<b>22</b>
<b>CH. 6</b>	<b>ACHIEVING BUILD SCIENCE™ . . . . .</b>	<b>26</b>
<b>CH. 7</b>	<b>WATER MANAGEMENT . . . . .</b>	<b>31</b>
<b>CH. 8</b>	<b>AIR TIGHTNESS . . . . .</b>	<b>36</b>
<b>CH. 9</b>	<b>VAPOR AND VAPOR CONTROL. . . . .</b>	<b>40</b>
<b>CH. 10</b>	<b>WRAPPING UP WITH THERMAL MANAGEMENT . . . . .</b>	<b>43</b>

### Here's the blueprint for our journey ahead:

- **The Art of Why:** We'll start by examining the very essence of why we build. Sure, it's about shelter and space, but there's a layer of meticulous science and innovation that elevates our structures to masterpieces.
- **More Than Just Shelter:** Dive into the realms of comfort and health. We'll discuss how the choice of materials and techniques dictate aesthetics and influence well-being within our creations.
- **Legacy in Bricks:** We'll unpack durability, revealing why certain buildings brave centuries while others don't quite make the mark.
- **Energy – The Modern Gold:** We're going deep into the intricacies of energy efficiency and its two-pronged magic: making the most of available energy and retaining it. And let's not forget our environmental oath in this equation.
- **Applied Wisdom:** We'll discuss the fine balance between theory and practice, bust some common misconceptions, and emphasize why sometimes asking the right questions is more vital than knowing all the answers.

- **Battling the Elements:** From ensuring zero water ingress to mastering the fine art of thermal management, we'll delve into the elemental control layers that make our buildings resilient and robust.

This Build Science™ 101 series will sharpen your foundational knowledge, introduce game-changing concepts, and perhaps even challenge a few beliefs we've held for years. Whether you're breezing through this guide or tuning into our video sessions, be prepared for a transformative journey through the art and science of building. It's time we build not just better but smarter.

We believe completing the series will increase your confidence and ability to make smart, informed decisions. It'll help you navigate those crucial chats with your clients, shifting their gaze from just the beauty of their dream home to a deeper understanding. This way, they'll grasp the essentials for their health, comfort, and safety, all while boosting energy efficiency and long-lasting durability.

By familiarizing yourself with the science behind building, we hope that, as you continue to work in this industry, you deliver the best possible outcome to your clients—healthy and efficient structures that can withstand decades of use without fail.

*It's time to take control.*

## HOW TO USE THE BUILD SCIENCE™ 101 COMPANION GUIDE

Congratulations on taking the next step in your journey by accessing the Build Science™ 101 companion guide! Here, we aim to make your learning experience both enlightening and flexible. Let's delve into how you can make the most of it.

- **Parallel Learning:** If you're embarking on the Build Science™ 101 series from the beginning, we recommend reading this guide alongside. As you watch each video, follow along with the corresponding section here to deepen your understanding, and get additional insights.
- **Quick Reference:** For those of you on-the-go, or in need of a rapid refresher on specific concepts, this guide has been structured to facilitate a swift overview. Jump to any section to get a concise view of the facts.



© Build Productions LLC 2023

- **Easily Accessible Videos:** In this guide, you'll find links or QR codes that directly lead you to the Build Science™ 101 video series. Whether you're reading on your tablet, smartphone, or computer, tapping the video thumbnail will bring you straight to the video content. For those reading a physical copy of this guide, simply scan the QR code within each chapter to watch the accompanying video. This seamless integration ensures that the visual experience is always at your fingertips.
- **Test Your Knowledge:** At the end of each chapter, a quiz awaits! This isn't just a simple test but a tool to reinforce your understanding and gauge your grasp of the material. Engage with the questions, and remember, it's not about getting everything right on the first try but about learning and improving. As with the accompanying videos, the quizzes can be accessed by clicking the link within the digital version or scanning the QR code in your physical copy.

Whichever way you choose to use this guide, remember that the journey of learning is personal and unique to everyone. The path you take is up to you. Happy learning, and we're thrilled to be a part of your exploration into the fascinating world of building science!

By viewing the videos and successfully completing the quizzes, you can earn a certificate of completion.

## HOW TO EARN A BUILD CERTIFICATE:

- Watch the videos.
- Complete each episode quiz.
- Pass all assessments and receive a digital certificate that you can download or share on social media.





# Chapter 1

## WHY DO WE BUILD?

WATCH THE FULL EPISODE HERE:

One of the most important questions in our quest to better understand the essence of building is: *why exactly do we build?* This chapter will navigate the fundamental answer to this question, which is ultimately to gain control over our space. Let's begin to wrap our heads around control by diving into the concept of conditioned space, as well as the ability to predict outcomes.

build SCIENCE 1  
#1 WHY DO WE BUILD

### SO WHY, THEN DO WE BUILD?

Although there are many reasons, including:

- Shelter that provides structural refuge, safety, and environmental separation
- Staying out of the elements
- Storing our "stuff"
- Keeping up with the Joneses...

It hasn't been very long since our idea of a home worked more like this:

Screen doors let a breeze in during the summer while keeping out insects, attic fans drew hot air from living spaces below, and coal furnaces provided heat in the winter—even if it was a bit "sooty." Ideal temperatures involved the ones we could achieve with what we had—windows, doors, furnaces, fans, basements, and attics.

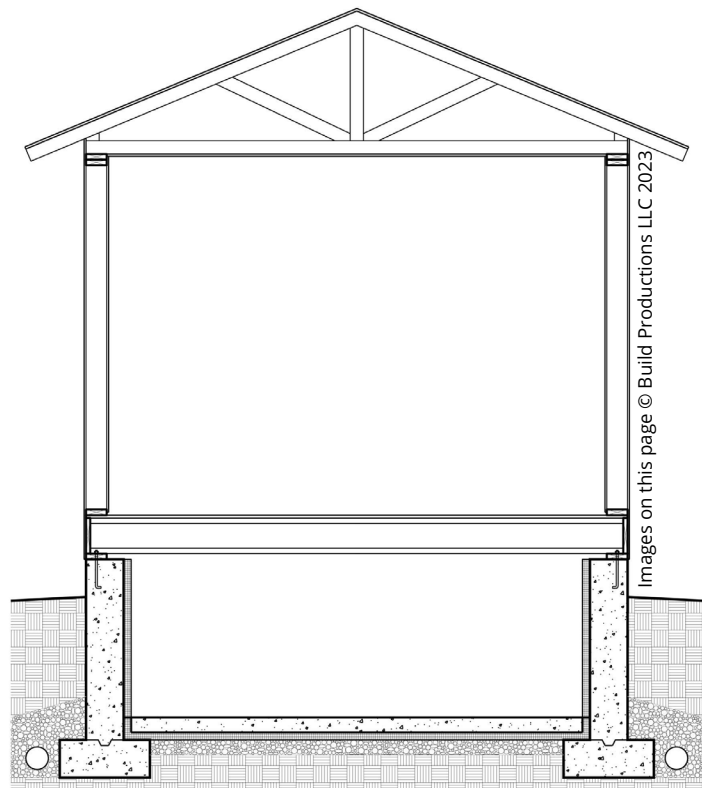

Hold onto this thought: Build Science™ was there when we built a campfire in a cave. Heat, humidity, and the idea of comfort were created. Over time we built on these concepts.

Only in the past 60 to 70 years have we become concerned about developing conditioned spaces. Before that time, houses were more concerned about being functional and providing safety than developing comfort. They were as functional and safe as they could be using the building practices of the day.

Creating a conditioned space means manipulating our surroundings to deliver ideal living conditions. Therefore, control goes beyond just cool or warm temperatures and consistent humidity levels in this context. It no longer means simply surviving within our indoor environment—but thriving in it.

We'll say it again: we build because we want control over our environment. That control encompasses refuge, safety, and environmental separation for sure. However, building, more importantly, provides a habitat that we can customize and one that we can predict to satisfy our individual health, comfort, and needs. This is the definition and goal of “conditioned space.”

## DEVELOPING A “CONDITIONED SPACE”

Of course, there are a few scattered examples of “conditioned” space within a residence that go back more than 100 years. The idea of “conditioning” the spaces within a residence came to the forefront within the last 60 to 70 years. Why this timeframe?

### Some reasons include:

- The end of World War II and higher incomes brought a perspective of a brighter future that developed the idea of suburbia and extended the concept of the American dream: marriage, house, and creature comforts.
- The invention of air conditioning in 1928 and its insertion into single-family residential use
- The new forms of heating technology led to a higher level of space conditioning.
- There were finally sufficient assemblies that enabled the ability to predict and provide consistency to “condition” our space.

The “control” we seek in our modern shelter translates to a set of conditions we utilize to create “conditioned space.” Today, our ability to understand, define, develop, and implement conditioned space is at its highest level ever, and it is directly proportional to the level of desired comfort in our homes.

It's important to recognize that all environments are not created equal; hence there's no “cookie cutter” approach to delivering conditioned space uniformly across the country. Sometimes the environment involves intense heat, high humidity, or arid low-humidity conditions—or it's just downright wet or cold. Depending on where you live, the outdoor environment's challenges will differ.

When we think about building, we're saying that we simply don't want to be out there but rather in here. What does that mean? It means different things in different geographic locations. In Austin, Texas, at two o'clock on a summer's day, we don't want to be “out there.” It's 100 degrees with high humidity. We'd rather be “in here,” where it's 70 degrees and 45% humidity. In International Falls, Minnesota, in December or January, we don't want to be “out there” because it's at least very uncomfortable, if not freezing.

When you consider the population bases in North America, in the northern states, it's a little milder in the summertime but certainly cold in the winter. In the past, we've had more concern about the ability to heat our homes than cool them. A century ago, we had fireplaces and fires. However, suppose you look at the population growth in the Phoenix area. In that case, even though it is super-hot in the summer, population growth has been dramatic due to our ability to implement residential air conditioning. The same is true for all Southern States—still rapidly growing population states. Our building expertise now dramatically improves comfort, health, and efficiency.

## BEYOND LIFE SAFETY

Building isn't just about creating a physical structure that shields us from the rain or provides control over temperature and humidity.

Safety is always our first concern. If the home does not stand structurally, nothing else really matters. When we build a sound structural solution, the home can then deliver satisfactory conditioned space, not too hot, not too cold, not too dry, and not too humid. Like porridge in a fairy tale – we like it “just right.” While just right may

not be perfect for every person, it narrows the spectrum. There is a “science” to building. This science directly relates to the materials we build with, the equipment we use to condition the interior air, the assemblies we use to “control” the interior conditions, and the practices we follow during the building process. We achieve the resulting “science” conditions through the building process - hence the term *Build Science™*.

So, we’re using science to help us gain control of everything around us. Not just rain, not just basic shelter, or safety from animals or intruders. We’ve got everything under control in our environment.

### What have we achieved from the Build Science™ approach?

- Greater energy efficiency
- Predictable control of our environment
- We developed a more comfortable interior environment
- We implement a healthier living space
- We gained the ability to build more durable structures
- We realized the need for environmental responsibility

It does boil down to control- ultimately, what we’re looking for.

As we step out the other nine episodes (or chapters if you like to read instead of watch) of our Build Science™ 101 series, we’ll still talk about control. There isn’t a choice we make about building or architecture that doesn’t fall back to the baseline of control. Even everything that we bring in after we build under the umbrella of Build Science™ has some level of tie back to the word control.

### THE SCIENCE BEHIND BUILDING – “BUILD SCIENCE™”

As we mentioned, we turn to Build Science™ to create conditioned spaces that give us the level of control we desire. The discipline looks at building not just as a creative or physical process but as a scientific one that applies the principles of physics, chemistry, and engineering to the design and construction of buildings.



© Build Productions LLC 2023

One of the most misunderstood concepts of *Build Science™* is when to insert it into the construction sequence. We hear, “We’re going to build a better home, so we want to add Build Science™ to our methods.” Today, when we build, we invoke Build Science™. It is a series of physical metrics governed by science that results in certain predictable conditions. We CANNOT ignore that Build Science™ is part of the first two materials we put together.

The systems approach to Build Science™ involves considering every aspect of a building as part of an interconnected whole. For example, temperature and humidity in a house don’t just depend on an HVAC system. They also depend on such factors as insulation, the building envelope, the house’s orientation, and, as we’ve discussed, even the local climate.

Our bodies mirror the way buildings function. Just as our bodies maintain a consistent internal temperature and humidity, so should our homes. Both operate on a system of interconnected components that work together to maintain an optimal and consistent internal environment.

So, we build not just to create physical spaces but to develop “conditioned” spaces that we can control. By applying Build Science™ principles, we can design and construct buildings that meet our evolving expectations for comfort, safety, and sustainability. The next chapters will dig deeper into the application of Build Science™ in our building practices, providing an insightful journey through the complexities and nuances of modern-day construction.

**THINK YOU KNOW A THING OR TWO ABOUT WHY WE BUILD? TAKE THE QUIZ TO FIND OUT.**

**TAKE QUIZ**



# TAKE BUILDING FROM **NOW TO NEXT**



**LEARN MORE**





# Chapter 2

## THE BUILD SCIENCE™ BEHIND DURABILITY

WATCH THE FULL EPISODE HERE:

**build**<sup>1</sup>  
**SCIENCE**<sup>1</sup>

#2 WHY BUILDING SCIENCE - DURABILITY

The most important thing we can do for a building is make it last! Said another way: if a building doesn't last, IT DOESN'T MATTER!

Everything that goes into building is driven by this underlying concept of durability. In Chapter 2, we'll see that Build Science™ is durability-based. Comfort, health, energy efficiency, environmental responsibility, and more rely on durability. As a builder, architects, or homeowners, it is our responsibility to ensure our buildings will last a long time.

### LONGEVITY IN CONSTRUCTION

We all know of century-old homes that look amazing. Why have these homes lasted so long? One reason is they were energy *inefficient*. Think about it. Hundreds of years ago, an old wooden church was built out in the middle of a field with huge beams right down into the dirt. There'd be a wood stove or fireplace inside. That heating source pretty much baked the building dry. That's right. The lumber was in a perpetual kiln. We don't do that anymore.

In this old church, energy basically flowed through the walls. In the summer, it would heat up. Even when rained on, that wood would still dry since there are not many places on Earth where it rains more than the sun comes out. If there's more sunshine than rain, it's all good.

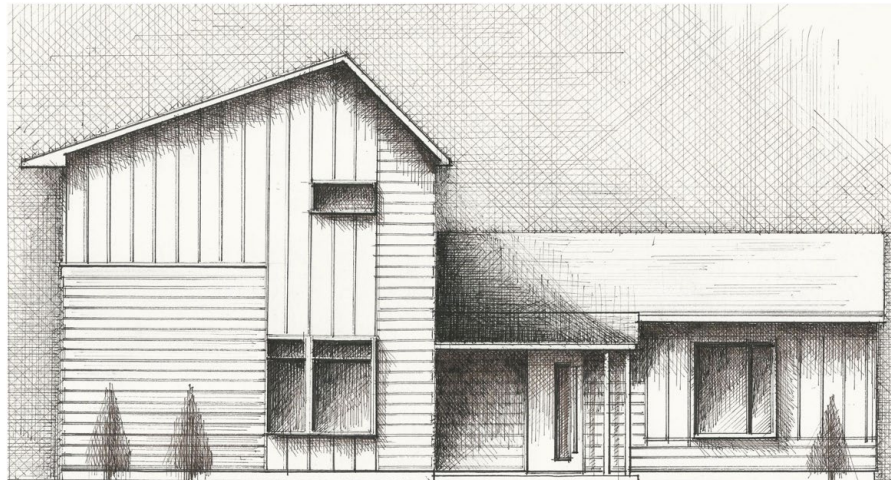

© Build Productions LLC 2023



However, the minute we add different layers to a building, the energy from the sun won't make it through the walls as efficiently. In Build Science™, we say that the wall is "less forgiving." Old buildings were far more forgiving—you simply baked them dry.

So what about old homes? Were there problems with the way they were built? Well, yes. For example, historically, many houses weren't insulated, which resulted in a large amount of heat loss. When these same walls held the energy from fireplaces and coal furnaces that dried them out, our walls became less forgiving. For example, things like plaster cracks are caused by several factors, including temperatures, relative humidity, soil conditions, structural components, and more, but the imposed conditions of the heat loss-wall drying cycle became a primary culprit.

### **What about today? How do we achieve durability in construction? We apply Build Science™ to today's structures. This includes:**

- **Construction details such as the proper installation of insulation, appropriate flashing around windows and doors, and correct grading around the foundation**
- **An environment that can be counteracted using humidification and dehumidification as required**
- **The longevity of a building is contingent on selecting the proper materials. In addition, the proper materials must be installed correctly to put the materials in a position for success.**
- **The outdoor environment can also affect the long-term durability of these materials.**

In reference to the indoor environment, typically, a humidity level of 30% to 50% is comfortable for occupants and minimizes movement of natural materials due to moisture content. A stable level of moisture content results in a minimal amount of movement in interior materials creating, thus creating a long-term successful solution for the interior environment.

Compared to older inefficient homes, today's wall assemblies have much less energy moving through them due to energy codes, insulation, and overall gains in efficiency. As a result, less energy moving through the walls means less energy to dry them out.

One more note about old homes—houses built in North America before 1900 had what can be thought of as a

big golf umbrella—huge overhangs. If you have that golf umbrella, it doesn't matter what you have on for a raincoat. You won't get wet, except for your shoes or the bottom of your pant leg. It's when we took away that golf umbrella and put up a smaller one, and suddenly, we got wet with the smallest amount of wind pushing the rain coming down.

The more sophisticated the building assembly, the more sophisticated the knowledge behind the assembly is required. Today's assemblies have much less energy moving through them because of building codes and gains in efficiency. Durability is the key.

## **WATER AND BUILDINGS DON'T MIX**

Water is identified as the "number one killer" of buildings, as it can lead to rot, mold, and structural damage. Despite the understanding we've achieved regarding the detrimental effects of water, the construction industry often fails to adequately address water with viable solutions integrated into the design and construction process. From design features that direct water away from the build to materials that resist water damage, proper water mitigation is crucial to durability.

## **I'VE HEARD THAT THE #1 CONSTRUCTION DEFECT LITIGATION ISSUE IS WATER**

We tend to think we can overcome Mother Nature. While we may win a battle or two over the years, a water war is seldom won. Water intrusion represents our industry's most expensive callbacks. A sliding door that leaks must be replaced. However, when the water came in, it ruined the hardwood floor, which now means you're sanding the whole floor. If we want our buildings to last, how we protect them and manage water within our buildings and assemblies matters.

If you take one thing away from this series, it is the question: where does the water go? Where does the water go when we look at how the ground is graded? When we're in the basement, where does the water go? If we have an entrance door, it makes sense to put a porch roof over it, right? Where does the water go? Well, if the roof doesn't go over the door, given windows and two-story walls vs. windows under overhangs—under the overhang, maybe we're not worrying about where the water goes. Still, water is coming down on an unprotected second-story window. We can build the best, most efficient house in the world, but what have we done if we don't get flashing details right and water gets in, and the building rots? Nothing.

Mother Nature always wins. She is the greatest adversary that the building industry has.

Interestingly, as much as we now understand water and durability, I've never had a building inspector come out and say, "Hey, let's do a water management inspection." Nobody really talks about how to provide solutions for water management. They immediately want to discuss how much insulation is in the wall.

If you're a young architect or builder, and you want to build something that will last, bring everything that provides the control we spoke of earlier into that building, but make durability your number one priority. If it isn't your number one priority, you're doing it wrong.

## DO HOUSES NEED TO BREATHE?

The common saying "houses need to breathe" is often misunderstood. While we've discussed that older houses were designed to allow airflow through walls, modern buildings are designed to be airtight for energy efficiency, necessitating mechanical ventilation systems.

Because the building is based on science, "breathing" needs to be understood, controlled, and conditioned, or filtered, if needed. With modern insulation and building materials, the concept of a house "breathing" has evolved. It is now more accurate to say that a house needs to manage moisture effectively to ensure durability.

Let's look at it this way. Let's say we had a client and a builder, and the builder states that houses need to breathe. We may want to explain this further to the client and say let's give you two scenarios. We can bring in outside air, and we can bring outside air in and condition it. We can take that conditioned air, run it through a filter or two, and then send it into the house, or just let air come in through all the nooks and crannies. So, Mr. or Mrs. Client, which scenario do you prefer?

If you're so confident as a builder, client, and architect that buildings need to breathe, try telling your clients to leave their windows open an inch all year or open the windows even more and let that house breathe. You would never do that.

That church in the field with a fireplace in the center baking the walls did breathe. They had airflow through the walls and heat go through the walls. We have modern building codes today, so we can't just build like we did in the 1700s. Ultimately, we can't let houses breathe uncontrollably.



If we do, we start getting into unhealthy situations for our clients, long-term durability issues, and even building failures. Unless you're building that uninsulated church in a field, toss that concept of buildings needing to breathe—and opt for durability in everything you do.

## THE NEED FOR SOPHISTICATED UNDERSTANDING

As buildings become more complex, builders, architects, and even clients must develop a more sophisticated understanding of construction and design practices to ensure durability. This includes knowledge about how different materials and designs interact with environmental factors and how these interactions affect the longevity of the building.

At the highest level of understanding, as the architect or builder, we need to grasp what we're doing when we put a building together. Bill Belichick says it best: "Do your job."

Durability is a key factor in Build Science™. Architects, builders, and homeowners must prioritize durability in their construction and design decisions to create structures that can withstand environmental stress and last for many years. By understanding the key factors that affect durability - from material selection to water management - professionals in the building industry can ensure the longevity of their structures.

Durability should be prioritized in building design. Good architectural design is not just about aesthetics but about embracing durability.

**THINK YOU KNOW A THING OR TWO ABOUT DURABILITY? TAKE THE QUIZ TO FIND OUT AND EARN YOUR CERTIFICATE!**

**TAKE QUIZ**





WHEN YOU'RE BUILDING TO THE **ZIP** CODE,  
IT'S A DIFFERENT WORLD ENTIRELY.

We make the right products to do the right job, the right way, the first time. No matter what the region or climate, you can count on ZIP System™ Building Enclosures to streamline the performance of your air, water and thermal barriers for structural assemblies. Is your project Built to the ZIP Code™? See why others have made the switch at [ZIPSystem.com](http://ZIPSystem.com). #BuiltToTheZIPCode



© 2020 Huber Engineered Woods LLC. ZIP System, the accompanying ZIP System logo and design are trademarks of Huber Engineered Woods LLC. Huber Engineered Woods' ZIP System® products are covered by various patents. Please see [ZIPSystem.com/Patents](http://ZIPSystem.com/Patents) for details. HUB 82431 REV 7/21

**ZIPsystem**<sup>™</sup>  
BUILDING ENCLOSURES



## Chapter 3

# THE BUILD SCIENCE™ BEHIND COMFORT AND HEALTH

Back in Chapter 1, we learned that we build for many reasons; the most important is control of our environment. While we take control of the environment, we're also saying we control the level of comfort we desire. Homeowners appreciate comfort, whether temperature and humidity-dependent or based on aesthetics that provide a comfortable and comforting space. Health plays a role in all this, too. But as for the concept of health—that's somewhat invisible—making it a bit trickier. We'll explain.

### WHAT IS COMFORT?

Comfort should be looked at from a builder's, architect's, and homeowners' point of view.

**For builders & architects, delivering comfort means:**

- How temperature, humidity, and other factors contribute to the conditioned space
- Understanding and incorporating climate tuning into the building design

WATCH THE FULL EPISODE HERE:

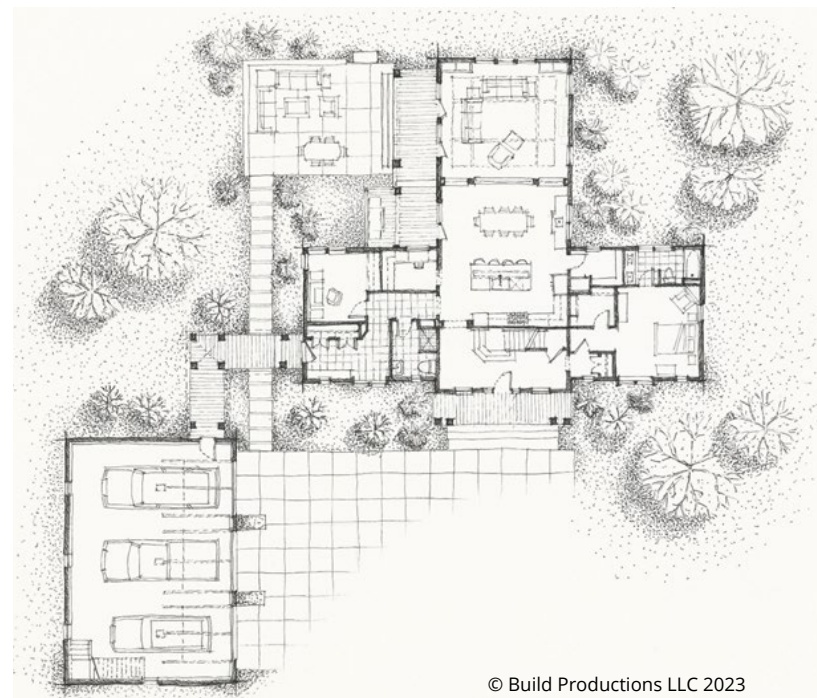

© Build Productions LLC 2023

- The role of mechanical equipment and their correct utilization in delivering comfort

### For homeowners, it is:

- A key factor identified within building design
- Will the environment be “just right” no matter where the homeowner is within the home?
- Will the materials lend themselves to be aesthetically pleasing as well as useful?
- Is the design of the space easily maneuvered?
- Do I feel good in this space?

There’s no one standard approach to comfort. For example, if we’re building in Arizona or Montana, we must “tune” or select assemblies based on location. Climate tuning is a relatively new concept. An analogy for it would be if you’re visiting Louisiana, you pack a specific type of clothing. You don’t pack the same clothing when you go to Montana in February. So, if you’re looking to build in New Orleans, Phoenix, or Helena, you better have three different sets of “clothing.”

Because everyone’s comfort level is different, we tune within a range. You might find 70 degrees comfortable, and I might like it a little cooler at 68 degrees. However, to adjust the inside temperature, you must grasp what’s happening outside—a concept many builders and architects don’t understand. For example, some build using 2 x 6 walls with plywood and building paper wherever they build and never really question it.

The second critical aspect is that tuning equipment must match the house. We’ve walked into a modest-sized house and, on the way in, noticed three condensing units outside. The builder says that this house has six tons of cooling. And you’re like, “But it’s 2,400 square feet. Why six tons?” When we do our job tuning it to the local climate, tuning the equipment should be a pretty easy process.

Most people tune their houses for comfort with a thermostat. We try to place those thermostats on a middle wall, between spaces without direct sunlight. But that thermostat only has one readout—temperature. Yet, our bodies have a lot of receptors for comfort. Humidity plays into comfort too, so when the thermostat on the wall says 70 degrees, you still may not be comfortable if there’s elevated humidity or you’re in an area with direct sunlight beating down on you.

As we gain control of our buildings and move from control to actual comfort and health, if there’s elevated humidity in our house, many things can cause problems that can develop because of it, like mold or dust mite activity. All sorts of things happen and elevate as relative humidity passes 60%.

It isn’t easy to find someone that understands building a well-tuned house. It would be best to tune the equipment, and the equations will get you there. It’s not enough to punch in numbers if you don’t understand what they mean. It’s a collaborative effort. It’s a sizing calculation by an engineer or a trained person that inputs data into a computer program. I have this many square feet of walls facing this direction (let’s say West) that will catch the West sun + *this* many square feet of walls facing in this direction + the level of insulation, air tightness, windows sizes, etc.

They input the data into the energy program that provides the HVAC design data. In the summertime, the data is provided as heat gain to the house. Conversely, in the winter, the data provides the heat loss the house will have. Typically the data is delivered as BTUs (British Thermal Units). In contrast to older days of residential HVAC design, where loads were calculated as a “rule of thumb,” today’s residential design should solely rely on calculations. It’s essential and will significantly affect the home’s comfort level. Since comfort and health go hand in hand—let’s jump into building and health.

## HEALTH CONSIDERATIONS IN BUILDING DESIGN AND MAINTENANCE

We typically talk about building health in terms of air quality—but it’s so much more. Let’s start with air quality and then visit other elements that play into health.

As mentioned, our bodies are an excellent example of what our houses should be doing. If you think about how we take in air, the air goes in through a dedicated input. It’s not leaking through our skin or holes in our necks. Right? Air goes through a dedicated input to a filtration system and is immediately available—the same with our houses. Many companies offer different types of filtration and air cleaning systems depending on your climate zone and location.

Getting rid of a pollutant once in the house isn’t easy. “Dilution is not the solution to indoor pollution,” according to Joe Lstiburek. Consider coffee grinds from the bottom of a coffee cup as a pollutant. If we pour it into a clear glass, even overfilling the glass with water, is the water

perfectly clear? No. The coffee is diluted, but it's still brown water. The same is true for air in our houses. Texas has many moldy days and high pollen days (which means bring on the allergy medicine). We want to be healthy, so we want to keep these pollutants out of the house. The best way to solve a problem is to not create it.

People often have sensitivities to the materials we use, such as sealants, tapes, and adhesives. As our building assemblies become more complex and efficient, we rely on various adhesive products to seal to provide air tightness. There is the potential to be living with an abundance of chemicals in our homes.

Dealing with air quality doesn't stop once the construction is finished. Furniture, carpets, and other similar items have chemicals for fire retardancy and stain resistance. If you're diligent about your job, you want to suggest that your homeowners "air out" that furniture before bringing it

## A STEVE STORY

*A client once told me, "I have a rule, no adhesives." Think about that for a second. She told me I had to build a 1,800-square-foot addition with no adhesives. That doesn't just mean the stuff coming out of tubes on the job site. It means no plywood, board sheathing, floor joists, rafters, and studs. When I sent it off to the structural engineer, he said, "Are you serious? Do you know how much this is going to cost?" That was what the client wanted. We built it with no glue or adhesives, and she was happy.*

*What's important about this is that it was a real experience to work on a project where everything we use and rely on daily was suddenly eliminated. That was an extreme case. But we do have some people that say, no spray foam in my house, or adhesives or tapes. It's your responsibility to have this conversation with your clients.*

into the house. There are classes of things that will off gas and be done. However, some things will off gas for the life of the product. While we're not going to visit that in this series, for future study, these include vinyl floors.

A word of caution: Although spray foam and oil-based paints off-gas rapidly, no one should be in the structure when being applied or installed without using a proper respirator and ventilation. A lot of these things become somewhat inert. Personally, when I've walked through houses without putting a respirator on when foam

and paint are sprayed, the back of my throat gets itchy immediately.

*If you want a long life, think about the materials again. Here are two examples. Cement boards are widely used today. It doesn't rot, deteriorate, or dissolve. Think about what that means when that sawdust gets into your lungs. Another material is cedar. I walked up to a job where a cedar roof was being installed, and the crew was wearing masks. I had never seen anyone wear masks installing a roof and asked about it. The response was, "Well you use cedar, so it doesn't rot. What do you think will happen when all that cedar sawdust gets in my lungs, because I've been breathing it all day? It doesn't rot. It's just going to sit in my lungs." The health of the building and the health of the builders working on it deserves much more attention than it often gets.*

*"I've heard a building scientist say, "Everybody's always worried about the air quality. The stuff that comes in on the bottom of your shoes is probably just as important as anything coming in through air filters." When I'm designing houses, I always create entry areas where people can take off their shoes, store them and then walk in."*

Another important consideration is cleaners and air fresheners. There are tons of cleaners, and they work well. But think about how a cleaner peels the grease right off the stove. Why do you think it is that easy? Chances are it's probably not that healthy for you to be in there breathing the fumes. Often, things that work really well are not very good for us. And that's also true with air fresheners that typically off-gas volatile organic compounds (VOCs).

As the builder finishes the house and turns it over to the homeowners, they must understand the systems in place. Ensure the homeowners know how to run the AC, heating system and how (and when) to change filters. If they don't want to do that, you can set up a maintenance cycle to change their filters for them on schedule and charge a fee.

## A NOTE ABOUT FILTERS

During the COVID crisis, everyone discussed minimum efficiency reporting value (MERV) ratings. Your HVAC system, for example, has a MERV rating. The higher the MERV rating, the better the filtration. MERV 11 is generally regarded as adequate for most buildings. MERV 13 is even better (which I use), and MERV 15 is close to HEPA quality and is used in hospitals for filtration.

Regarding filters, it's also important to understand the difference between units. For instance, my thin dehumidifier filter is changed every six months. The thicker filter on my HVAC system (two-inch filter and some four-inch filters) means more material is inside to catch particles, allowing us to go a little longer between filter changes. We need to think about maintaining these. Ultimately, the particles in a suspension in the air won't go into our lungs if we can filter them out.

So again, it's about control. If we want to develop comfort, we must build a good envelope and have the right people size the equipment. That equipment must be installed properly and commissioned correctly. Once the job is finished, ongoing maintenance is just as important as everything we do up until handing over the keys to the homeowner.

## GOOD BUILDING PRACTICES

Although a closed environment protects us from a lot of exposure, it also means artificial environments can create new situations affecting human health. Designing a healthy and sustainable indoor environment is a necessity. If we look at each element of comfort and health and

attack it in a vacuum, we will likely not achieve the results we're looking for.

If we want to focus on energy costs alone, we may forego adequate ventilation that increases our homes' moisture levels and pollutants.

However, if we take a holistic approach based on solid building practices and look at comfort, health, and well-being, we're traveling down the right path. A holistic approach to an indoor environment acknowledges that it is a complex system that should be devoid of quick fixes and unscientific methodologies.

**THINK YOU KNOW A THING OR TWO ABOUT COMFORT? TAKE THE QUIZ TO FIND OUT.**

**TAKE QUIZ**



# Pros who know GO SASHCO

*Upgrade your caulk!*

Request Free Samples >







# Chapter 4

## ENERGY EFFICIENCY AND ENVIRONMENTAL RESPONSIBILITY

Building a house involves thousands of decisions. The important ones really aren't about green, platinum, or silver labels—it's tuning each project to a client's budget and working with them to achieve the best possible result in energy efficiency and environmental responsibility.

As we talk to our clients about building their homes, efficiency is not usually their number one concern. Comfort is. Fortunately, with the right decisions, efficiency can be a by-product of comfort. For example, when less heat flows through our walls, we are potentially more comfortable, which positions us to gain control. This also allows us to use less mechanical equipment to maintain that control. On the contrary, when we have little control, such as a lack of insulation and air tightness, the result is more mechanical systems. When we gain control and comfort in our houses, efficiency will be forced to accompany it.

Earlier, we talked about tuning the house and building assemblies to the local climate to get control.

WATCH THE FULL EPISODE HERE:

**build<sup>1</sup> SCIENCE<sup>1</sup>**  
 #4 WHY BUILDING SCIENCE - EFFICIENCY AND ENVIRONMENTAL RESPONSIBILITY

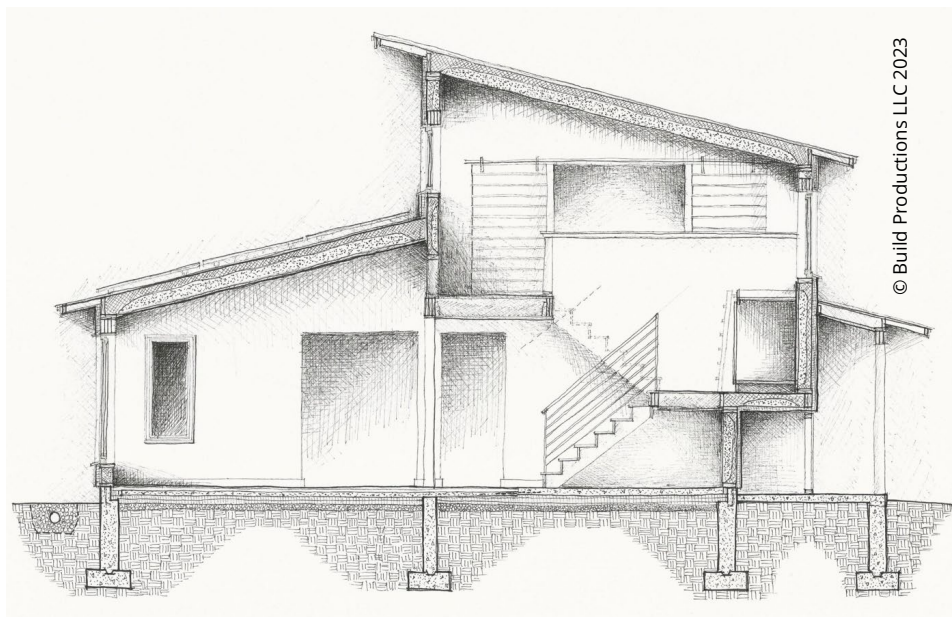

© Build Productions LLC 2023

It's the same with energy efficiency. We want to hold on to whatever heating or cooling we have for as long as possible.

## UNDERSTANDING ENERGY EFFICIENCY AND ENVIRONMENTAL RESPONSIBILITY

When we consider efficiency and environmental responsibility, stewardship is the underlying concept. While a steward doesn't own something, they are tasked with caring for it. When you build, take on that role of steward.

Let's look at energy efficiency as a "two-headed monster." You want to convert the energy for your building as inexpensively as possible and hold onto the converted energy as long as you can. In cold climates, we buy energy, convert it, and heat our buildings because it's cold outside. Heat always tries to equalize, moving from hot to cold. In cold climates, typically, the heat flow is from inside to outside.

In hot climates, we purchase energy and convert it to cooling to offset the outdoor environment, which is usually uncomfortably hot. In this case, heat from the outside is trying to get into the building and equalize the interior temperature. HEAT ALWAYS MOVES FROM HOT TO COLD.

Back to the "two-headed monster." The very first part of energy efficiency is that we need to purchase energy to transform into heating or cooling at the lowest cost. We also want to convert it as inexpensively as possible. The second part of that two-headed monster holds that converted energy for as long as possible. That is the fundamental basis for energy efficiency.

## DEBUNKING MYTHS ABOUT ENERGY EFFICIENCY

Heat moves from hot to cold, and cold does not move. Here's an example. Fifteen years ago, high-end coolers were just beginning. If you were using a cheap foam cooler filled with ice every day from the convenience store to keep beverages cold, the ice would melt by the end of the day. Maybe you were on the job where some of the crew had fancy new coolers, and their ice lasted even though both the cheap cooler and the fancy one were parked in the sun in sweltering temperatures.

Given that heat moves from hot to cold, the cheap cooler would heat from outside temperatures, melting the ice inside the cooler. The high-end coolers have a

few features that make them better at retaining ice—features that relate to our walls and houses relating to how moisture moves. Again, heat moves from more to less based on physics and the principle of heat flow and moisture. It affects how we insulate our buildings and how we control both moisture and vapor. And it controls why we want to achieve air tightness in our houses. If the cold air moved, the ice would never melt. It would instead continue to grow ice as the cold moves. The fact that ice melts suggests that heat is the only part of that equation that's on the move.

When we build, and it's zero degrees outside, the interior heat is trying to escape seeking an equalized position with the colder air outside. So, as that heat moves across that assembly to the outside, we lose the heat we want to hold onto. However, when we reverse that order and build, let's say, in Texas, where it's 100 degrees outside and 70 degrees inside, the heat wants to move from the outside to the inside of the home, seeking an equalized position. Mother Nature has a very simple rule. It moves from hot to cold—it's Build Science™.

When building, you need to ask yourself, if I want it to be 70 degrees inside and the outside is X number of degrees, which way is the energy flowing across that assembly? Something else to consider is that when talking about sunlight (and its heat energy), people say they'll just put shades on a window to deal with the heat. If you put shade on the inside of the house, the heat energy is already inside the house—the shade does not affect heat energy. It blocks the light but not the heat energy that already came in through the window.

Now, let's think about cooling and the fact that cooling doesn't move. In the north, where it's cold, if we want it to be 70 degrees inside and zero degrees outside, the delta across that wall is 70 degrees—that's a rather large delta. That wall needs to perform exceptionally well. To a lesser degree, in Texas, in the summer, when it's 100 degrees, and we want the inside to be 70 degrees, there's a smaller 30-degree delta. Gaining control is about creating an assembly or building to accommodate the parameters of control in either situation—little to no control = little to no efficiency. Energy efficiency is the result of CONTROL.

## ENVIRONMENTAL RESPONSIBILITY IN BUILDING

The first rule of environmental responsibility is the minute we choose to build a new building, we choose a level of

*irresponsibility*. That's not a typo. For example, a new home in a field will never be as environmental as the original field left alone. It's discouraging to see someone put up a new house and know that the decisions of that house are environmentally irresponsible. They'll say, "Well, we're building to code." Remember, you have thousands of choices, and at least 100 would add little to no cost but would make a world of difference in that house and place it in a far better position to succeed. Gaining control, comfort, health, energy efficiency, and durability can provide success, and environmental responsibility enhances that success.

Environmental responsibility is a moral choice, not something in a codebook. The building inspector doesn't care about your moral choices, carbon counting, and carbon footprint. In all of the possible decisions involved with home building, we want to try and make the best ones.

Regarding remodeling, we are choosing to cease the service of the building's components and provide new ones. In this case, there should be an argument that the remodeled structure will perform significantly better because we are using new resources. It is our responsibility to ensure the new life of the building and its associated performance is better than the original.

Building a new structure or remodeling an existing one puts us in environmental debt that we must try to minimize. We're in debt to the environment and should be trying to work our way out of that debt. If you build, you're always in debt, which raises the only question—"How much debt do I want to take on with this build?"

## CASE STUDY: DAN'S HOUSE

Dan is a retired mechanical engineer that built his retirement home. Dan has measured everything regarding his house. He's performed all kinds of tests. His house is up on Cape Cod in the northeast. It's a passive house with a nice southern orientation. About 57% of his heating bill is served by the heat energy from the sun. When we talk about purchasing energy and getting it as inexpensively as possible, orienting the house correctly allows for that sunlight.

If you built that house in Phoenix, you might have a problem with the sun streaming in. He'd either be cooking or paying a lot for air conditioning. But climate tuning that house for that environment in the northeast played a significant role.

In addition to the proper orientation of the house, the south elevation, which receives the most sunlight (heat energy), also occupies the highest glazing ratio of the four building elevations. The south elevation comprises 38% of the area as glazing (aka windows). In contrast, the north elevation receives little to no sun and is a mere 7%. The east and west elevations are comparable to the north. Maximizing glazing proves to be an asset to energy efficiency.

## COMPARING BUILDING MATERIALS: HARDWOOD VS. LUXURY VINYL FLOOR

Let's talk about embodied energy by diving right into an example. Take luxury vinyl tile. Somewhere in the world, we're extracting many chemicals, many of which are petroleum based. Once extracted, they're transported to be refined and then shipped again to a manufacturing plant, which may be halfway around the world. The flooring will be produced and sent somewhere else for sale and use.

Now, consider white oak that may be cut and milled 200 miles from your house. It's then delivered via truck. In this case, the white oak possesses less embodied energy than the example of luxury vinyl flooring.

Embodied energy is all that cumulative effort from extraction to delivery to installation. Once delivered, we need to buy some type of adhesive that was also extracted somewhere, mixed, and then put down on the vinyl floor instead of a nail that goes into the oak floor.

This is not an exercise in judgment—but one that attempts to expand your thinking. When you visit your local lumberyard or resource center, you might want to ask a few questions: Do you know where that's manufactured? Do you know what that's made from? Do a little research since there may be an alternative that gets you a little bit more out of environmental debt.

One more thing. In the U.S., it's difficult to find homes standing and in decent shape when they're 100 to 200 years old. Traveling to Japan or Europe, that's not the case. In Japan, we've visited buildings that were 1,000 years old. In England, we stayed in a tavern that was built in the 1200s. It gave us a different perspective on longevity.

One of the goals of this series is to prove that this achievement is not hard. It's just different and based on a few different choices. We can build to last several



hundreds of years without a problem. What a different environmental responsibility and footprint we'd achieve.

Here's an example of one of those choices involving hardwood floors. We're a big fan of white oak floors. Over the years, we've pulled up a lot of white oak floors, sanded and refinished them, and made a 100-year-old floor look brand new again. White oak is a very slow-growing tree. It's a precious commodity. Yet these trees are sustainable and an excellent environmental choice for a floor because they are durable and easily reconditioned.

Compare that to a luxury vinyl floor that looks amazing and much like wood the day you put it down. Ten years from now, it will be disposed of into a landfill. It can't be re-sanded or refinished, so it simply gets replaced. The same is true with carpets. Not only does carpeting hold onto things that your feet bring in, which get released into the air, but within a few short years, it too will be replaced. These are costly choices. However, sometimes the more costly choice is the more environmentally thoughtful choice.

## CONCLUSION

Whether we undertake new construction or remodeling, we must consider energy efficiency and environmental responsibility—to take on the role of steward with every

project. The questions that we answer for ourselves first and our clients second involve the purchase and retention of energy, the sourcing of materials—and are there better choices to be made, and how do I elevate the role of steward on this project?

There is no reason longevity shouldn't be part of the decision-making process.

Instead of bragging about how aesthetically great our builds are, let's try to equalize those efforts with performance and how we minimized our environmental debt when building. Now, that's impressive.

**THINK YOU KNOW A THING OR TWO ABOUT ENERGY EFFICIENCY AND ENVIRONMENTAL RESPONSIBILITY? TAKE THE QUIZ TO FIND OUT AND EARN YOUR CERTIFICATE!**

**TAKE QUIZ**



# OUT WITH THE OLD

You came to know us as Poly-Wall...



# IN WITH THE NEW

But get to know us again as



The same great products you've always used with a fresh new look

Use **BS101**  
for 10% off your purchase

Order from us directly at:  
[www.polyguard.com](http://www.polyguard.com)

## Chapter 5

# WHERE IS BUILDING SCIENCE?

Like trying to find Waldo on a busy face-populated page, in this chapter, we're looking for exactly where to find Build Science™. We'll look at the where first, then the why and how of Build Science™, as well as its importance in construction.

Many mistakenly consider Build Science™ and performance the same concept, but they're wrong. Build Science™ is inherently all around us. For example, if you nail two boards together, the joint can hold water. That water could be absorbed by the boards, changing their moisture content. As a result, the double thickness of wood increases its thermal properties—doubles them, in fact. The air that circulates around the two boards individually is restricted in the two connecting planes, thereby limiting the drying potential of the two boards. See where this is going?

### **BUILD SCIENCE™:** **APPLICATION VS INTEGRATION**

A common misconception is that Build Science™ can be *applied* to buildings and, more importantly, a building's design. Build Science™ is inherently every part of the building and must be understood and treated as such. Build Science™ is an interrelated systems approach to all buildings. A successful integrated approach can be *developed*, not applied.



**WATCH THE FULL EPISODE HERE:**

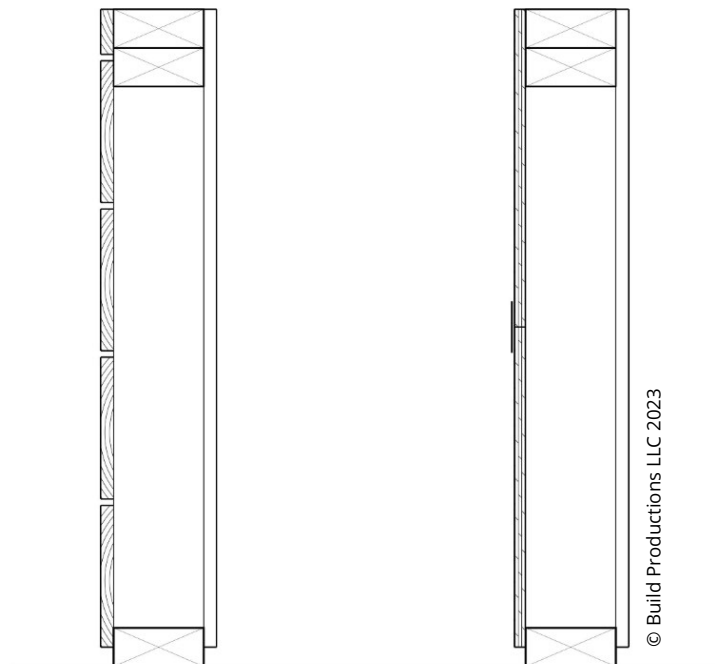

© Build Productions LLC 2023

We've heard statements from builders who claim they've been in the industry for 10 to 15 years and yet have just started using Build Science™. Take a moment and let that compute. Build Science™ is in everything we do. If we dig a hole in the backyard for a shed's foundation, we're messing with Build Science™ since we're changing the hydrology of the ground.

Build Science™ is an integrated aspect of building. It's not something you apply later. It's not a product or a technique. It is, by default, part of every decision that we make and every solution we execute. It's an understanding. That's what this series is all about: giving you knowledge and experience so that when you look at a building or an assembly, you can see it relative to the integrative science and how water, air, and moisture will affect or alter that building over time.

## THE PROBLEM WITH LABELS IN BUILD SCIENCE™

To enhance marketing messages, the building industry has developed a few programs and labels to illustrate varying performance levels. While labels help understand and distinguish performance, they, unfortunately, portray Build Science™ as an “add-on” to the building to make it better. While Build Science™ can certainly be enhanced in all building assemblies, it was already there at the most fundamental level when those two boards were nailed together.

Since marketing has gotten involved, myths and ideas seem slightly tweaked and sometimes stretched. Granted, a marketer's role is to position their client as a front runner, so they'll spell out every potential marketing advantage. However, from a Build Science™ perspective, you can say whatever you want but drop the labels. We can rattle off all the passive and platinum houses we've built, or the

Greenbelt residences and Zero-Energy homes—but the reality is we're using the knowledge we have on Build Science™ to deliver the best possible product.

*The very first passive house project we worked on, we met with our client who said, “I want to get a passive house certification.” (passive houses were in the U.S. for no longer than a month or two). They asked, “Do you know what that is?”*

*“Oh, yeah!” I said while excusing myself to the bathroom to Google it and bail myself out.*

*What is it? It's a series of metrics involving energy use and air tightness from Europe. It's rules to build by to achieve a very high level of performance.*

*I have trouble making peace with this. When people say that they build high-performance homes, what does that mean? Does it have an enhanced insulation package? R 19? R 21? I've had builders say that they built some of the tightest houses in the state. So, I ask them, “What's a blower door number on a typical house for you?” When he asks, “Well, what's a blower door?” I know this builder has no clue about airtight houses but will tell clients that his are the best houses in the state. Maybe he does have the best airtight house, but he doesn't actually know if he does.*

### | An Enlightened Homeowner May Ask:

When interviewing a builder or architect, a homeowner with a bit of education on the topic might ask about water management strategy. On a new construction house, they may ask what your thermal or vapor strategy? How do you achieve air tightness in your homes? What's your water management strategy so that I don't have a leak in my basement? Be prepared to answer those questions.



Understanding that Build Science™ is always a part of the process for builders and architects ensures that we are always heading in the right direction. Labels kind of cloud, the reality of what you're already doing.

## GAIN WISDOM VS. KNOWLEDGE IN BUILD SCIENCE™

Build Science™ is really a perspective. It's understanding first that it's everywhere, and you must acknowledge and accept it. Followed by how do I integrate it and put my building in the position for success. You can use Build Science™ to your advantage to do nearly anything you want in a building, but we just need to know what we're trying to solve or what our goals are. The remaining question is, how do we integrate that stuff?

All these pieces must go into a house. Which ones can I tweak to improve Build Science™ and a better integrative process? If you built the same house the second time you built it, you should have learned something from the first house that you can incorporate for a better house the second time around. Every house should be slightly, incrementally better, than the last house you built. Every house is a one-off. Every house is a prototype to some extent. While we still use the same systems, many times the same subcontractors, and the same materials, we're

going to make every house a little bit better and get every detail a little bit tighter than the last time.

## CONCLUSION

If you want a real hands-on education, take on a remodel. Remodeling can give you a Ph.D. in Build Science™. When you slowly remove siding from around a window and look at why it rotted in one area and not in another, or why it crumbled in one spot, or why one area is stained but the rest isn't, that's how you learn how buildings work. When you ask the questions, you'll find the solutions to integrate this time, putting your build in a position for success.

Now that we understand that Build Science™ is inevitable in building, Chapter 6 will take us through the four control challenges, or control layers, we face. As we'll soon see, fully understanding Build Science™ means embracing these control layers in concert, not individually.

**THINK YOU KNOW WHERE TO FIND BUILD SCIENCE™? TAKE THE QUIZ TO FIND OUT AND EARN YOUR CERTIFICATE!**

**TAKE QUIZ**



© Build Productions LLC 2023





FLOATING STAIRS | MODERN RAILING





# Chapter 6

## ACHIEVING BUILD SCIENCE™ THE FOUR CONTROL LAYERS

In Chapter 6, we begin to turn the corner. Until now, we've been talking about control to understand Build Science™. We've talked about why we do it and where to find it, but now the question becomes, how do we do it?

Every problem needs a detailed approach to arrive at a successful solution.

The challenge with building is that the end result wants to be a controlled environment. The desire to control is why we build in the first place. How we develop control must solve for comfort, health, durability, energy efficiency, and environmental responsibility—our approach to arriving at successful solutions begin here.

### UNDERSTANDING THE CHALLENGES OF CONTROL

Through understanding comes solutions. Knowledge comes best when we simplify our goals. So, here are specific things we want to control:

- We need a barrier to prevent the air from moving through our building assemblies
- We need a water management system to ensure long-lasting durability of our buildings
- We need a vapor management system to handle the moisture within our building assemblies
- We need to be warm when it's cold outside and cool when it's hot outside (also known as thermal management)

WATCH THE FULL EPISODE HERE:

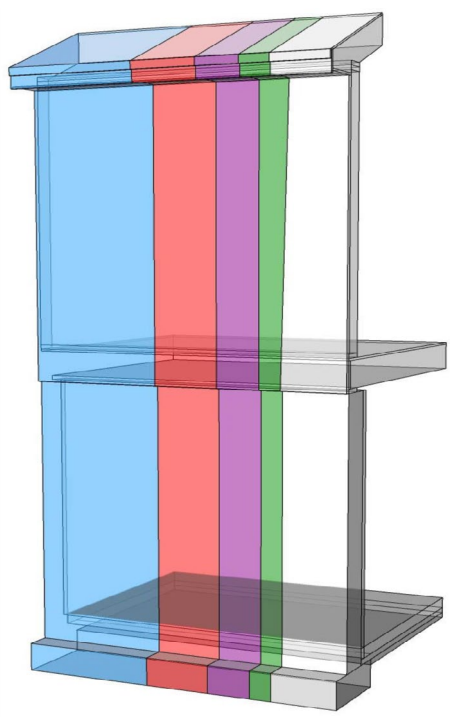

© Build Productions LLC 2023

To arrive at viable solutions, we must develop systems that control each challenge—what we'll now call "control layers."

### There are Four Control Layers:

- Air management
- Water management
- Vapor management
- Thermal management

From a more practical point of view, it is helpful to divide the functions of our enclosure into sub-categories to which we assign actual materials, products, and assembly components:

- Water Management Control Layer (e.g., drainage plane and gap or waterproofing)
- Air Management Control Layer (e.g., an air barrier system)
- Thermal Management Control Layer (e.g., insulation, radiant barriers, etc.)
- Vapor Management Control Layer (e.g., vapor retarder or vapor barrier as required)

Each Control "layer" may involve a single material or a series of components delivering the desired outcome. A single material or layer often addresses two or more control functions. A membrane, for example, may provide water and air control. Spray foam insulation may deliver vapor, air, and thermal control.

When we successfully manage these four layers, we achieve a controlled environment that is healthy, comfortable, durable, and energy efficient. While the control layers are listed as separate entities of control, they are inextricably reliant on each other (Systems Approach). Remember, Build Science™ is an integrated set of systems, and the four Control layers must be considered in concert, not as solo entities.

## ORDER OF THE CONTROL LAYERS MATTERS

There is a real sense of urgency to deal with the challenges of the water control layer. We've said it a few times already. Water is the #1 killer of buildings.

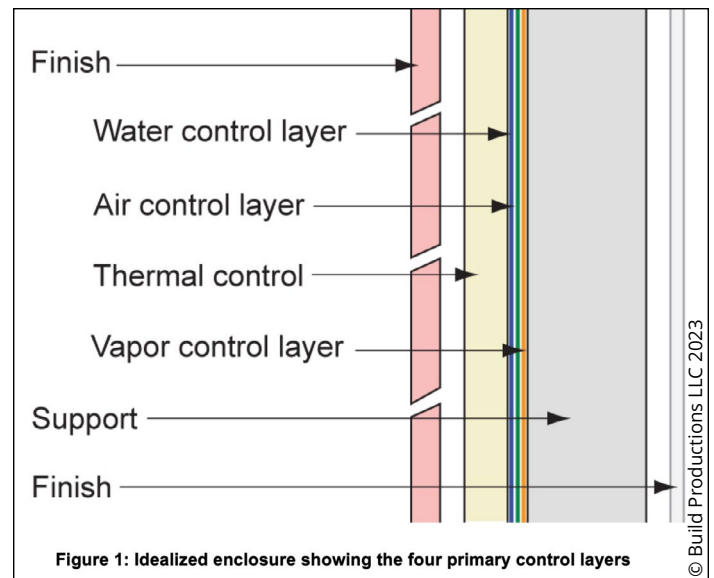

As a builder, if you make a mistake on the water control layer, your phone will ring (probably at midnight). However, if there's a thermal issue—it's too hot or too cold in a room—that won't be a midnight call. When we think about order or importance, we prioritize them in this way: water, air, vapor, and thermal.

In some instances, materials can be more than one control layer; in rare cases, a material may be all four control layers.

Windows are our water management system, air management system, vapor management, and thermal management system. We need to understand that the control layers are not always individual materials. Drop the myths that the control layers are rigidly separate. They aren't.

There is a strong interconnectedness in Build Science™. For example, if air leaks, that air might find the dew point on the inside surface of a wall or a building assembly, causing condensation. If that happens repeatedly, you could develop a water management problem that would soon elevate to a comfort and health problem.

Dispel any thoughts about the four control layers acting in a vacuum. Everything is a potential air barrier and a potential water management system. Every system's success relies on the degree of success of the specified material(s) in the system. In our thousands of decisions, we must select suitable materials for the job and, most importantly, consider having the right integrated approach to achieve Build Science™.



## MEASURING AIR TIGHTNESS

Water management is typically measurable by simply using our eyes. If you see water inside a building, you know there's a problem. How do you know if an air management system is leaky? The building industry has verification systems. For air management, we have what we call The Blower Door.

A blower door is calibrated fan that sits within a shrouded frame. The setup is typically in one of the door openings of the house. With the house sealed, the blower door applies a specified pressure, measuring the air across a fan at that pressure and then identifying how much leakage the building has, given the volume of the building.

We pressurize the house to a specified number measured in Pascals. Typically the goal is to achieve a 50 Pascal difference between the outside and the inside. Since the fan is calibrated, we can determine how leaky the house is. The blower door test results are simply the measurement of *how leaky the house* is. We aim to reduce those leaks to achieve a lower number rather than a higher number.

We've talked about how all of this is integrated. But let's talk about some of the apparent differences we encounter. People may ask, what's the best air barrier? If we're in the basement, it could be the concrete slab, or it could be the drywall or some other wrap. What is the best insulation? Well, it could be air-permeable insulation in a cavity or a

rigid insulation on the outside or the inside of a wall. It could all be the same material. There are places in our homes where one singular material is used for all control layers, even all four. - think glass.

## CONTROL LAYERS AND MODERN HOUSING

Modern houses and building techniques have adapted to manage control layers effectively. Think back to that church we talked about in the middle of the field. It's a wood building with a wood stove. Sitting in that field was probably comfortable. Water was likely managed to ensure that the occupants at a service stayed dry.

Rewind another 500 or 1,000 years. What did we build with before wood or before settling in North America? Think about the cathedrals and churches of Europe. They were all masonry buildings with some version of rocks stacked on each other. Rock in the cathedrals did a decent job repelling water but not a great job managing or controlling air, vapor, or thermal. It was more like that wood church in the middle of a field.

As we fast forward to modern buildings and techniques, we can still make older styles work, but we must think about it differently. As discussed in this Build Science™ 101 series, we now have modern building codes that emphasize building durability and energy efficiency.

## EVERYTHING IS A CONTROL LAYER

We teamed up with our buddy Jake Bruton a few years back for a podcast giveaway featuring a very efficient cooler. To draw a parallel between a cooler and a modern home, Jake and Steve literally sliced the cooler in half. Just like modern homes, the cooler isn't only about insulation. It boasts both a robust thermal layer and a very effective airtightness layer. Once cut open, we observed a complete gasket around the lid and dense insulation – demonstrating the balance of thermal control and air sealing.

### Think of it like this:

Even with the best insulation or walls, leaving your windows and doors open is like having a leaky bucket. Proper energy efficiency isn't just about insulation; it's also about ensuring windows and doors are sealed tight. With controlled airflow, the thermal regulation in your home drastically improves. Keep those windows and doors snug, and the warmth stays in—no doubt about it.

Everything is a control layer. You'll be freezing if you're in Minnesota and wear a Build Show™ shirt outside in the winter. But wearing a Build Show™ shirt is better than going out with no shirt, right? Just because you put rigid insulation on the outside, it doesn't mean it's an appropriate level of insulation. This whole idea of climate-tuning our buildings to the region and tuning the systems to our building is how we gain control. We understand we want durability, health, comfort, and energy efficiency, but how do we do it? Control layers are the key.

Our own human bodies are intricate systems of control layers enveloping a structural framework, all working in harmony for our survival. Our building should do the same thing.

In Chapter 7, we'll dive into water (pun intended). We'll focus on water management, the most important control layer of the four.

**THINK YOU KNOW A THING OR TWO ABOUT THE FOUR CONTROL LAYERS? TAKE THE QUIZ TO FIND OUT AND EARN YOUR CERTIFICATE!**

**TAKE QUIZ**

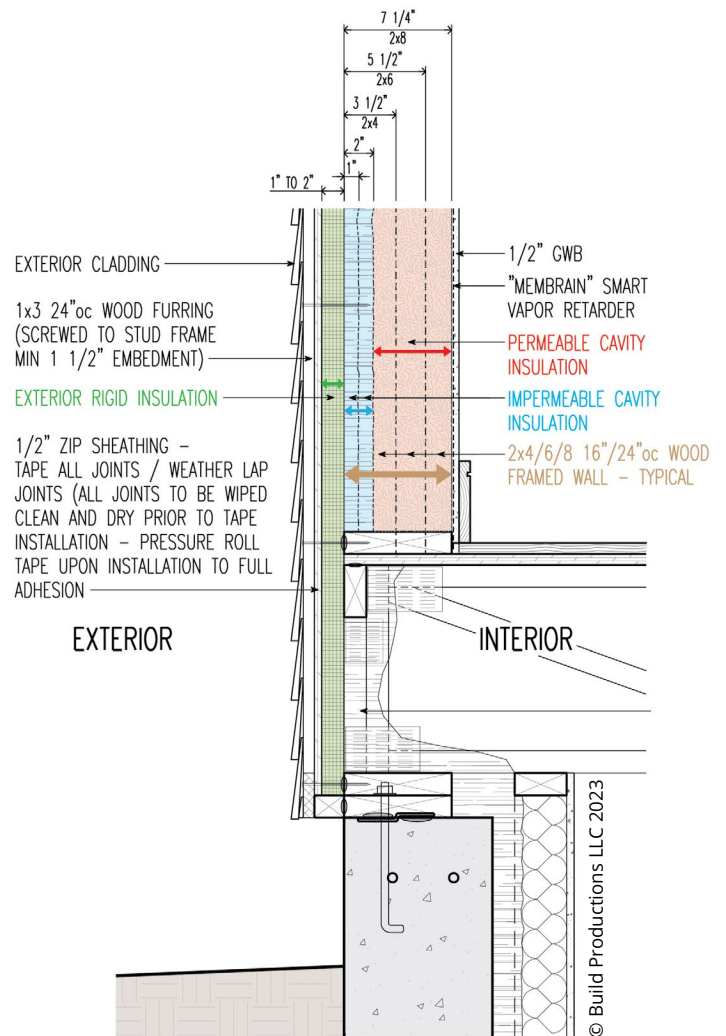

EASY CONNECT JOINING SYSTEM  
**REINFORCED WINDOW  
JOINING WITH 50% FEWER  
INSTALLERS NEEDED\***



[Learn more →](#)





# Chapter 7

## WATER MANAGEMENT

This could be considered the most critical chapter of the series. Let's think of water in three ways—protection, mitigation, and prevention. Water demands RESPECT!

We'll say it again. Water is the #1 killer of buildings, and water intrusion is the #1 reason for litigation in building performance. Risk is tied to the geographic climate and the exposure the structure and its components have to the weather. The easiest way to deal with water and maintain a low risk would be to protect the vulnerable areas and simply keep water off them.

Here's a simple building section with three different arrows; those three sets of arrows denote the concepts of water management. Arrow number one shows how our roof provides protection. It is nothing but an umbrella to the house. The second arrow demonstrates mitigation. When we provide water a path to go when it hits our building, we mitigate the effects of water. Finally, arrow number three represents the need to stop water from entering further into an assembly to prevent (third word—prevention) damage. We need to direct its path. Water management can be summarized in two words: Down & Out.

WATCH THE FULL EPISODE HERE:

build<sup>1</sup>  
SCIENCE<sup>1</sup>  
#7 WATER  
MANAGEMENT

© Build Productions LLC 2023

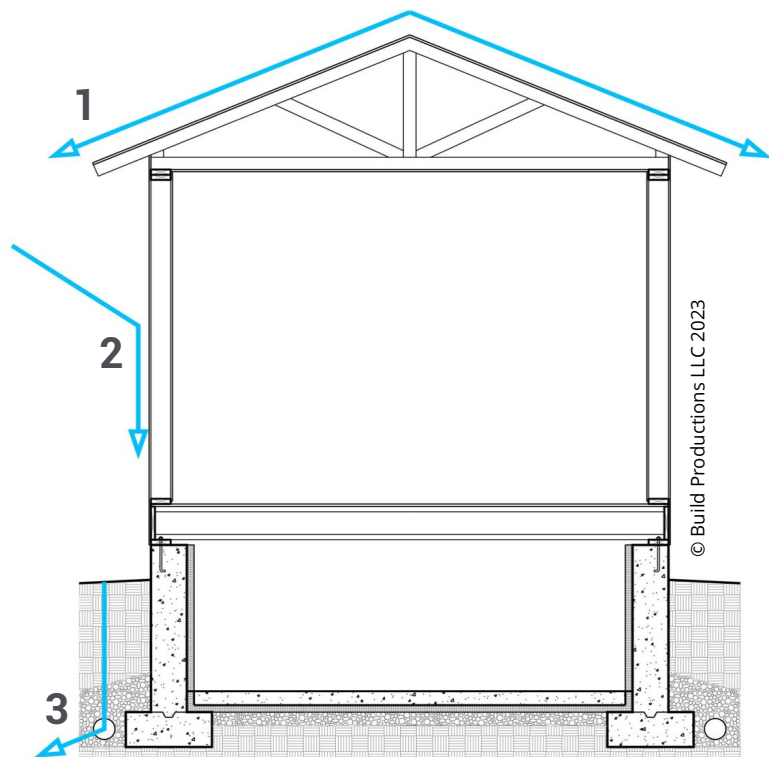

## PROTECTION

There are many architectural components available to ensure a high degree of protection. These include porches, porticos, roof overhangs, and canopies that immediately protect doors and windows that would otherwise be directly exposed to water.

The style of architecture can either make this easy or more challenging. If we have parapet walls and no overhangs, walls may see almost as much water as our roof. However, if we have a building with a sloped roof with a two-foot overhang and gutters, the likelihood of the wall seeing water is highly diminished.

Now, let's delve into the concept of aspect ratio. This is the proportional relationship between the width of the overhang and the distance above the window or door head. This ratio plays a crucial role in understanding the connection between the depth of a roof overhang and the potential for wall damage. Generally, the more extended the overhang, the better protection for the wall beneath.

### Depending on the climate:

- Dry regions might have homes with little to no overhang
- Mild climates typically feature overhangs of 12-18 inches
- Extremely wet areas opt for 18-36-inch overhangs

We aim for a 2:1 aspect ratio to ensure optimal protection. However, it's worth noting that the height of a building can affect the efficacy of the overhang. For example, in a two-story building where the overhang begins at 20 feet, the first-floor windows might still be considerably exposed to the elements.

## MITIGATION—PROVIDE A PATH

When absolute protection is not available, we must deal with the water.

### There are two fundamental options:

- A barrier system
- A water-managed system

A barrier system (typically surface-oriented) prevents the passage of water from one area to another—a dam, for example. A water-managed system creates a predetermined pathway within the assembly to



© Build Productions LLC 2023

move water without developing a problem—a canal, for example. We want to stop water from penetrating building assemblies on a building. The durability of our construction (which ensures longevity) relies on keeping water out. Because water exists in most climates, we are forced to deal with it. The easiest way to solve for water is to remove it from the equation.

Imagine we build a large mockup of a wall with a window in it. If we treat the face of the wall, the window, and the connecting components as the “water barrier system,” they are required to sustain successful combat against EVERY drop of water sprayed on that wall. If we place a screened assembly in front of the mockup, the assembly will combat most of the water and significantly reduce the amount of water the wall/window mockup then sees. By mitigating the water pre-barrier, the actual barrier system must work much less. Ask yourself, would you want the water barrier system in your home to battle a fire hose or a water pistol?

It's not an either/or proposition. It's not a choice between a barrier system and a water-managed system. Instead, it's a dual approach. We first want to develop a water-managed approach. We want to shed the water as fast as possible but in a controlled manner. After shedding the water, we turn to a barrier system to prevent the little remaining water from intruding. This approach minimizes challenges.

Thinking about mitigation for a moment, we add exterior finishes to look and feel good. But the primary purpose of that exterior finish is to get rid of as much water as possible and to keep UV rays off whatever is behind the materials. It's the sacrificial layer. The sun beats on it, the rain beads on it. Water freezes on it. That exterior layer gets tortured.



## PREVENTION

We touched on prevention by saying we must get rid of water to prevent damage. We need to get rid of it. Think down and out, or down, out, and away.

### Ways to prevent water damage include:

- Sloping ground away from the building
- Install rain gutters that move water away from the house
- Consider the hydrostatic pressure of water that could turn your basement into a submarine
- Take advantage of free draining when possible
- Understand what's involved with below-grade water management
- Waterproofing, which involves installation plus maintenance
- Pay special attention to sliders and flashing details on windows and doors

## A PLETHORA OF WATER MANAGEMENT WISDOM

Here's a general rule of thumb: The riskier the architecture, especially when it comes to water management, the harder it will be to put that house in a high position for success.

Austin, Texas, has a medium climate when it comes to rain, with approximately 30 to 35 inches of rain annually.



## WHAT CHALLENGES DOES YOUR BUILDING CLIMATE COME WITH?

If you build in Austin with no overhangs, parapet walls, valleys and hips, and all kinds of intersecting walls with roofs, it will be a challenging building with very little forgiveness built in. As a builder, in this case, every detail must be perfect. In comparison, a less-challenging house in Austin would include some overhangs and a ventilated attic that offers some level of forgiveness built in.

Since you're taking this series, think now about the challenging nature of your own climate and the prevalent style of architecture. If we consider buildings built 100 years ago across America, there were iconic styles—adobe houses of the southwest, New England colonial houses, and cabin styles in the Pacific Northwest. They were designed and built in an age without insulation, concerns about energy and energy codes, or chemistry-laden products to put inside. As a result, the houses were built and designed in a style that worked with the climate.

You don't see an adobe house with a parapet wall in New England and rarely see a colonial with overhangs in downtown Phoenix. Builders in these areas understood what they were building and built what was appropriate to the local risk.

Remember that building science is the collection of scientific knowledge and experience that focuses on analyzing and controlling the physical challenges affecting buildings and architecture. Its practical purpose is to provide predictive capability to optimize new and existing homes.

Here's a very simple takeaway about building science. The minute you break out a caulking gun, a roll of tape, or some type of adhesive closure membrane, the first

*We've had building failures over the years. I've personally experienced loss. In the early 2000s, a mold crisis hit America. On the nightly news, Tom Brokaw at NBC News Tom reported on the mold crisis, saying that insurance companies were paying huge mold settlement claims to homeowners and builders. As a young builder in my early 30s, I worried the mold in their leaky buildings would kill their children. That's when I started digging into building science, learning from different mentors, and trying to figure out what it is about building today, different from 20, 30, and 50 years ago, and whether we were having these problems then.*



question you should ask is, “What am I sealing in, or out?” Everything we put on the outside of our houses is to drain water. It’s the first line of defense to shed that water. It’s also keeping everything behind that from getting UV rays on it since just about everything we use in our houses is UV sensitive.

In North America, houses are generally wood structure buildings with some type of control layers, specifically related to water management, as is the topic of this chapter. On top of that is cladding. That cladding will let some amount of water through. But it’s the “Alamo layer” as we like to call it, that’s the line of defense. It must be waterproof, shed the water, and drain the water. Remember, for water, it’s always down and out. It’s why we use head flashings on our windows and sill pans underneath our windows. If our windows leak, they have something waterproof to leak onto and to drain down and out.

Behind our exterior finish is the drainage plane that acts as a stopping point. It’s commonly referred to as the weather resistive barrier (WRB). Not only do we want to stop water, but we want to give it someplace to go. That is our last stand for weather resistance.

## INSTALLING WINDOWS

Let’s talk about window installations. The minute you cut a hole and insert a window, the window must be protected from water. Most of the time, good window companies take care of that. Good window manufacturers also have mitigative solutions for their windows and components. If water gets in, they have weep holes to let it out. While we consider a window a barrier, it really isn’t. It’s a water-managed assembly.

There are two ways to install a window. There’s the barrier method. Most American windows have a flange to structurally install the window. It’s a flashing point that we use to stop the windows or the water from getting past the window. Using the barrier method means we’re flashing around the window, typically with some type of tape or sealant. And that is an approved method.

In our experience, however, it’s not the best method since it assumes that that window will never leak. We presume that windows might leak someday, no matter the manufacturer. We use a water-managed system that gives water an appropriate path of escape.

The other thing we will do when we install our windows is instead of using a barrier at the flange on the window on the outside, do just the two sides and the head and leave the bottom with some method to weep water out. We assume every window has some exposure and prefer to go to that best practice, avoiding the barrier method and, again, using a water-managed method.

While a compass has north, south, east, and west, a wind rose is a plotted graph of direction and how much rain the orientation gets. Most of our wind and rain in New England comes out of the Northeast. The Southwest exposure doesn’t get that much rain. In Texas, most storms and winds come from the south and west. Plus, if you build on a hill or a coastal house—you’ll have a lot of exposure.

One of the scariest things in architecture is being commissioned to design and build an 8,000-square-foot house on the coast. This house will be hammered with wind, rain, and salt water. If you’re building these houses, you really have to step up your game and pay attention to that risk.

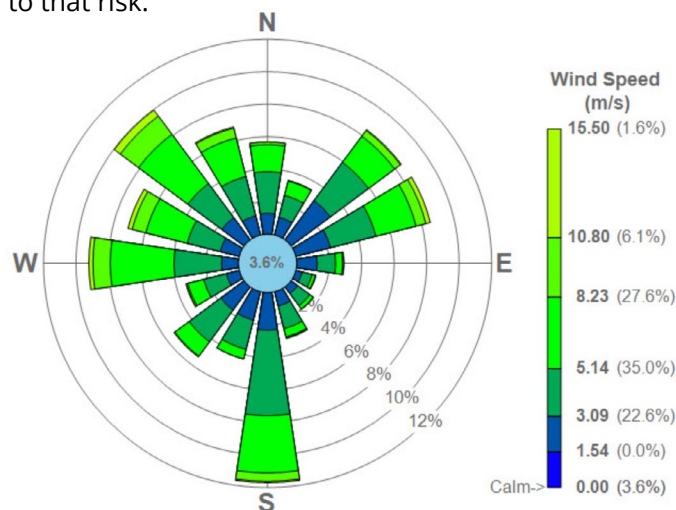

© Build Productions LLC 2023

## MORE ON MITIGATION

We talked about a sacrificial layer and mentioned using a rainscreen system. This is the suspension of our exterior finish in front of the drainage plane. There's a space that runs down in between. If we build a wall with a window and spray water on it, that wall will become significantly challenged. If you build a secondary wall, put it four inches in front of it, and spray it, that inside wall will see far less of the water than it saw when it was fully exposed. What little water does get in then simply falls to gravity inside that space.

Our grandparents understood this concept and built a lot of buildings with brick. Brick naturally has that air gap behind it. As the brick is laid, there's approximately an inch between it and the face of the structure. Often, there was no WRB behind those building layers. It was just brick. That air gap, however, provided a lot of forgiveness. This was a very early attempt to create a water management system.

Most of our clients come to us because of building science. They want to build a house that lasts forever. Maybe give it to their kids. While the client may trust a builder, they should still ask a few crucial questions. How are we going to mitigate water in our wall system? What kind

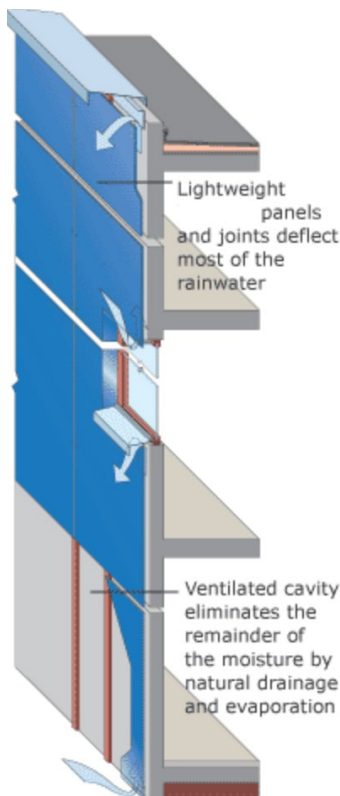

Images on this page © Build Productions LLC 2023

Boston, MA - Driving Rain 90° Incident, in./yr

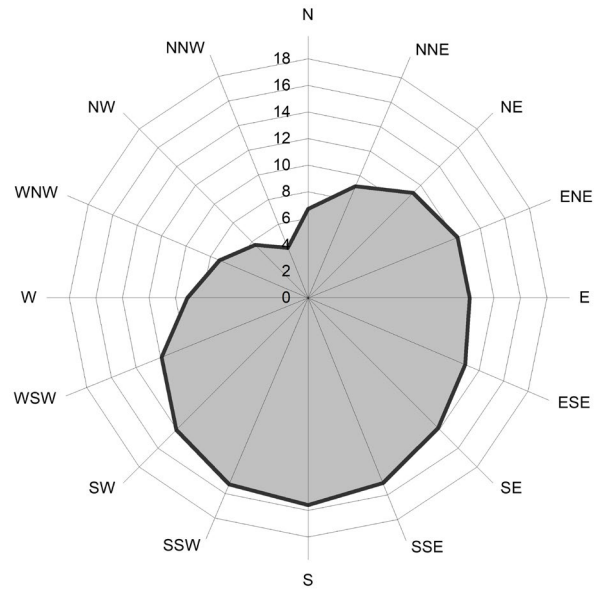

of windows are you using? Do they have a weep-hole system? Are you using caulk on my siding? If you are, does that water behind it have a way to get out? Be prepared to answer these questions.

## WATER MANAGEMENT RECAP

You must be tired of hearing that water is the #1 killer of buildings. But repeating it is that important. We've reviewed the importance of **protection, mitigation, and prevention**—read them again. Water management has everything to do with your success as a builder. And it has everything to do with the longevity of the building, the comfort of the home, and, as we've seen, ensuring clients will not have water damage that dramatically affects their health. Hopefully, we've given you a new approach to your building process. In the next chapter, we'll learn about providing air tightness.

**THINK YOU KNOW ABOUT WATER MANAGEMENT? TAKE THE QUIZ TO FIND OUT AND EARN YOUR CERTIFICATE!**

**TAKE QUIZ**





# Chapter 8

## AIR TIGHTNESS

Air tightness (or air control) is number two of the four control layers, just behind water management.

Not long ago, energy efficiency was solely based on thermal management (R-value). With the introduction of passive houses in North America came the understanding of an air tightness metric—a Blower Door test. With that, the knowledge of how important air tightness is to the control of a building rapidly took hold. With that, the knowledge of how important air tightness is to the control of the building and its role in energy efficiency rapidly took hold.

The blower door test is a measure of how tight we build the house. In most places, it's now part of the building codes. Today, when we build a house, we don't just build a foundation or exterior wall and then put a roof on it. We add windows, doors, electrical wires, HVAC, and plumbing through walls, and it seems like we have more penetration through our air barrier system than we've ever had before. We often do multiple blower door tests to see which building components contribute to its air tightness or lack thereof.

It's easy for builders to say, "I built a really tight house." How do you know? How do you know what's contributing to any air leakage?

WATCH THE FULL EPISODE HERE:

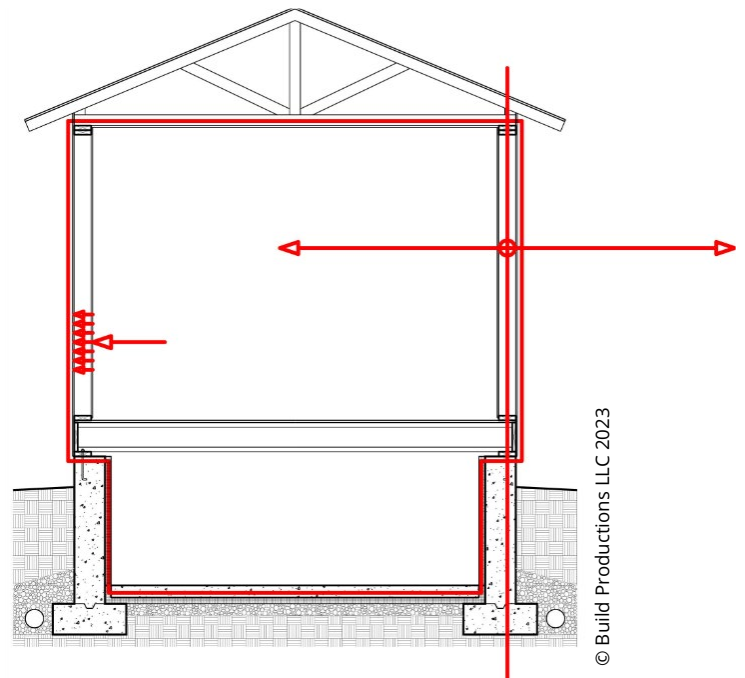

© Build Productions LLC 2023

Where do architects and builders target their efforts to build as tight as possible?

Years ago, when discussing energy efficiency, we examined our walls, ceilings, and windows. We'd rattle off the thermal properties and call it a good house. But the blower door test is a game changer—now we can finally measure air leakage. We learned that while R-value is important, energy efficiency is directly tied to how tight our build is.

When the passive house came to North America, one of its metrics was air tightness, and it was 0.60 at 50 Pascals of air changes per hour (ACH). Someone drew a line in the sand for air tightness for the first time.

## AIR TIGHTNESS MANAGEMENT

The first 30% to 40% of air tightness management is low-hanging fruit. Right? Seal this joint, run a bead of sealant along here, or put some tape across it. As recently as five years ago, no one cared about the blower door test. Now, we have codes dictating a score as low as 3.0. The test will become increasingly more demanding. You don't want to be the builder who needs to figure it out down the proverbial road.

Achieving lower and lower scores takes time. Let's look at the concepts involved—continuity, separation, and escalation.

## THE CONCEPT OF CONTINUITY

The most important aspect of air tightness is continuity. This tolerance of air tightness should be analogous to the water tightness of a boat. Whether there is one large hole or 1,000 very small holes, both scenarios harm the boat's success in staying afloat. Air tightness success is rooted in similar continuity. This is where the "Red Line Test" comes in.

Imagine looking at a building's design and tracing the air barrier with a red pen. If you can do this without lifting the pen and loop back to where you started bingo! You've got a continuous air barrier. It's not so much about the material you use but more about ensuring there are no breaks, especially when switching between walls and windows. Think of it as ensuring there's never a "gap" in your building's protective bubble. Simple but genius, right?

As we previously discussed, some think buildings need to breathe. If we live in a very hot climate or a very cold

climate, do you leave all your windows open an inch? Of course not.

Growing up in a 1950s house, we'd purchase shrink wrap and wrap the windows inside using a hairdryer. Shrinkwrapping was a way to keep the wind from blowing through single-pane wood windows. So, back to buildings needing to breathe. No, they don't. If we could build every house as tight as a hot air balloon, there would be zero air leakage. If we can't seal the house, we can't take control and provide a good environment.

It's no longer the 1950s, and we now test for air tightness using the blower door test mentioned above.

## THE BLOWER TEST: HOW IT WORKS

How does a blower door test work? You cover up one of your doors with this big sheet (think of it like a shroud) and insert a fan there. Once everything's sealed up tight, this fan either sucks the air out or blows it in – you can choose to go positive or negative with the test. Now, while it's doing its thing, we're measuring the airflow at a specific pressure. In most homes, that pressure is 50 Pascals. Now, if you're scratching your head wondering what a Pascal is, there's a neat way of explaining it. Imagine the weight of a falling piece of paper is roughly one Pascal. So, 50 Pascals, while more, still isn't a lot. The end goal of this test is to get a number telling you about the air leakage across your entire house, and by entire, I mean from the roof to the walls and right down to the foundation. Think of it as checking how tight the seal is on all six sides of a home's box.

The blower door test is not just a measurement of how well we did in the house. It's now part of the building codes. This isn't just theory; it's a requirement. It is one element of obtaining a certificate of occupancy in certain jurisdictions. As a rule of thumb, Steven Baczek, Architect, would say 1.5 or better is good enough. 1.0 or better is great, and meeting the voluntary standard of .6 or better is exceptional.

## THE CONCEPT OF SEPARATION

This concept is fundamentally simple, but for some reason, it seems to be one of the most difficult for the building industry to actually understand.

### Here it is:

We are either OUTSIDE or INSIDE —there is no gray area. There's no "maybe" in air tightness.



## CONCEPT OF ESCALATION

When good ideas are implemented wrong, or carelessly, they become a problem instead of a solution. This is true of air movement. A sloppy air barrier system approach or execution will result in unwanted air movement, detrimental to energy efficiency. This can escalate to even larger problems.

Moisture is in the air around us. As a vapor, it doesn't present a problem. When given the opportunity to condense, it can become a severe problem. Moisture carried by air movement is exponentially greater than moisture migration by diffusion. Air leakage can move a lot of moisture fast. If that moisture finds a cool surface below the "dew point," water will condense, changing from vapor to liquid.

The minute we introduce an air stream, things can jump on that air stream. Therefore, air tightness and water management are linked as control layers. Think about a piece of drywall with a 1-inch square hole.

Let's say we walk around a house and see that insulation is applied five feet up in a garage wall where mechanical equipment and an exterior garage "attic" can be peered into. If the insulation stops at five feet, we might think it's inside that wall. But remember, we don't want to know what's inside the wall. We're talking about inside the red line of the red line test to ensure optimal air tightness.

Various building components collectively form our air barrier, from concrete walls and ceilings to windows and doors. The crux isn't just about these individual components but where they intersect. That's where the concept of separation comes to life: ensuring a continuous divide, an unbroken barrier between inside and outside.

Take, for instance, the attic. Is it inside or outside? While technically under the roof, its classification can change based on design choices. It could be outside the boundary or, if conditioned, become part of the inside. These design decisions underscore the need for a clear understanding of separation. Builders and architects should be crystal clear about their air tightness strategy and how they delineate spaces like attics. If they can't clarify these distinctions, they're missing the essence of the concept of separation in their design.

**If your clients are enlightened, they may ask you the following questions, so be prepared to answer them:**

- What is your airtightness strategy?
- Is my attic conditioned or unconditioned?

If a builder can't define whether an attic is outside or inside, they don't even know what they want to control. Walk around your building and ask yourself: Am I inside or outside? There's no gray area. It's that simple. It's not rocket science. It's building science.

*Pull up a chair. Here's another story. I stopped by a builder I know who was in the process of building his dream home in Texas. When I walk in, there's ductwork, equipment, and all you'd find when building. In another house that day, we measured a temperature of 163 degrees in the attic, while outside, it was about 100 degrees. The attic for the builder's dream home was also an oven.*

*What's going to happen is we're going to purchase energy, put it through an air handler, chill it down to 68 to 70 degrees, and run it down the line. We expect the house to perform well. But remember, it's 163 degrees in that attic—worse than outside.*

*At that moment, I told the builder not only was putting his ductwork in the attic, in Texas, a bad idea, but he should have run the ductwork outside his roof where it would be more energy efficient. At 68 degrees, we would have knocked the Delta down to 32 degrees from 100 degrees.*

*This is just basic high school physics. Moisture moves from more to less, and heat moves from more to less. Should we put our ductwork into the hottest space in the house when we're trying to cool it down? No. It just doesn't make sense.*

Moisture migrates through a material, so 100 cups of water can move through that hole because it gets on the air train.

If you're in Minnesota, you'll probably find a cold surface—the cold surface changes to water when warm, moist air hits it. Our air tightness neglect is now a water management problem. While it can be cold in Minnesota because it's 10 degrees outside, inside the house is warmer and moister. People are breathing, cooking, or showering. With that one-inch hole in the drywall, as moist air flows, we suddenly have moisture problems inside the wall assembly.

We can think of another example of the connection between an air tightness problem and a water management problem. This \$20 million home had five-foot overhangs and a nice swooping slate roof. But, on the face of the fascia, there were all kinds of stains—brown ugly like zebra or tiger stripes. At first glance, you might think it was water intrusion. But it wasn't a water management problem. It was an air tightness problem. That overhang is a big opening. When you look at the materials, there was a slate roof, over paper, over plywood, and an exterior wall leaking air that was getting into the cavity.

Guess how nice and warm the backside of that plywood is in the winter? It's located in New England, where it's cold, so moisture is not only condensing but also doing so on the backside of the plywood. Stay with me here. That plywood is wood and has wood sugars that mix with the water, resulting in what looks like brown tea. Because of the slope, it runs right down, finds cracks, and runs off the fascia, leaving the residue and creating tiger stripes.

## CONCLUSION

Air tightness is directly tied to the energy bill. When the passive house concept came around, along with the blower door test, it was like setting a standard for the first time—drawing a line in the sand for air tightness. And even building codes have their own "line in the sand." While it's been a bit more relaxed until now, those codes are getting stricter. So, if you're building or renovating, brace yourself for these tougher standards.

And remember—it's important to know whether you're standing INSIDE or OUTSIDE the home.

Our next chapter is about vapor control—said to be mysterious, but it really isn't.

**THINK YOU KNOW A THING OR TWO ABOUT AIR TIGHTNESS? TAKE THE QUIZ TO FIND OUT AND EARN YOUR CERTIFICATE!**

**TAKE QUIZ**



© Build Productions LLC 2023

# Chapter 9

## VAPOR AND VAPOR CONTROL

Vapor is considered one of the most mysterious concepts related to building. Vapor, or “moisture vapor,” is all around us. All air contains some moisture content and is always trying to “equalize.” It also moves from “more to less,” a concept with which you’re very familiar with by now.

### AN INTRODUCTION TO VAPOR

We’ve talked about water management and air tightness. Now it’s time for the next critical layer. Vapor management is an illusionary tactic by the building science world to scare us. We must ask all the time, where’s your vapor barrier?

Vapor is not a problem—condensation is. Spend the Fourth of July in New Orleans. You’ll sweat a lot, which isn’t a problem until it condenses and becomes liquid water. It’s just a bunch of molecules, and as the temperature warms, those molecules move slightly faster. That holds moisture better than lazy cold air.

### RELATIVE HUMIDITY AND VAPOR

When we have warm air, we can hold more vapor. We measure vapor in the air as relative humidity. Using a temperature and humidity sensor, you can discover the air in your office is about 70 degrees and 50% relative humidity. The humidity percentage is relative to the temperature.

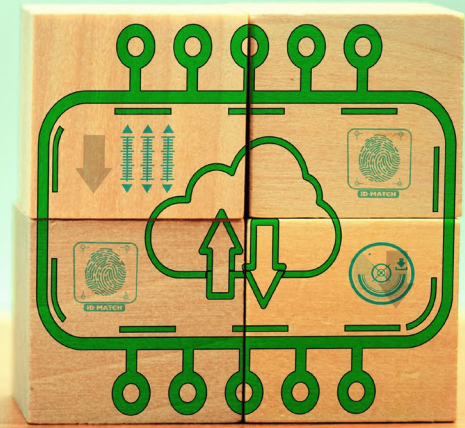

WATCH THE FULL EPISODE HERE:

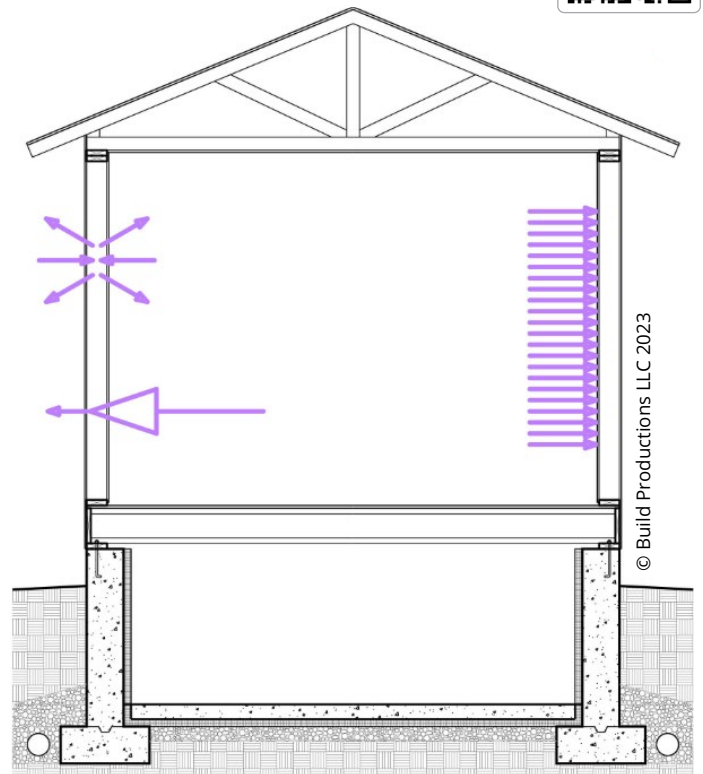



If we're outside in New Orleans and it's 90 degrees with 90% humidity, it feels uncomfortably humid, and a lot of moisture is locked up in the air. Conversely, with cold air, molecules move slowly so that, even though the relative humidity might be higher, there's less absolute moisture in the air in cold temperatures.

## VAPOR IN THE BUILDING INDUSTRY

So why is vapor mysterious? It really isn't. Here's the vapor myth. Most builders consider it to be a liability to their buildings. We already discussed that things can dry. The mechanism to keep a building dry is the same mechanism that allows a building to get wet. Vapor can be a liability, but it's also an asset. When things get wet, we need movement to dry things out. We build assemblies to counteract the problem and provide a path to remove it.

It's all about perspective. We need to stop thinking about vapor being harmful and understand the load upon which vapor hits our building.

There are two types of structural load: point load and uniform load. An example of point load is someone standing in the middle of a floor joist, exerting a specific amount of weight, considered a point load on the beam. If they lay down across the beam, it's still somewhat of a point load, but they've created a more uniform load and expanded it across a larger surface area.

Moisture is a uniform load. If there's high humidity in a house, it doesn't focus on any one square foot of floor area or wall area. It can't maintain that level of focus as a point load. Instead, it hits surfaces in a nice uniform load. That means our assembly deals with it as an all-encompassing load attacking the vapor barrier or smart retarder system.

When there's an area with high humidity next to an area with low humidity, the moisture naturally moves from the high-humidity room to the low one until it evens out. The same thing happens between the inside and outside of a house, especially if the walls let moisture migrate easily through. It always goes from wetter to drier areas. If all the air is connected, the humidity level will be relatively the same—a uniform load.

## UNDERSTANDING VAPOR BARRIERS

If we deal with the other important control layers, water and air vapor will usually take care of themselves. Typically, we want to use materials that allow vapor to

transfer through. That's referred to in the building science world as permeance or sometimes perm rating.

When asked, "What perm rating should I use on my WRB?" Ideally, not a zero, but beyond that, it doesn't necessarily matter—if you've dealt successfully with water and air.

As for vapor management, now we must buy into this question: let the water out by letting the vapor out? It's okay if things get wet, but the system must have more drying potential than wetting potential. If the water dripping into a bucket makes it too heavy for drying potential, we'll have problems. We're fine if it's a slow drip, and we have plenty of drying potential.

### | An Example

*I recently checked out a building aged between 150 to 175 years. Just three years back, it underwent a remodel where someone added insulation. By doing so, they inadvertently changed the energy flow through the walls. You see, those walls had been initially designed with a high drying potential—so high that you could've splashed water directly on them, and they'd dry out just fine.*

*But here's the catch: adding insulation reduced this energy flow, which cut down the drying capacity. Here's where modern technology comes in. Manufacturers have come up with 'smart vapor retarders.' These membranes limit moisture entry into the wall but have a trick up their sleeve. If moisture does find its way in, these retarders open up to release it. So, they help reduce moisture absorption while also ensuring effective drying if needed, all within a thin membrane layer.*

## VAPOR MANAGEMENT

Let's say you just drywalled a house and put plaster up. Guess what's in that plaster? A lot of pockets of water—barrels of water. The funny thing about water is it's somewhat like energy in that it goes into the plaster going on the wall, but it doesn't go away. The moisture is there. What happens? So, the builder gets a salamander heater that burns fossil fuel and dumps a ton of moisture into the room into an area you want to dry out. It's already humid and moist. In this case, the builder is contributing to the problem. This doesn't solve anything because heating up that air gives it the capacity to hold more moisture. The moisture of the wall and the moisture of that heater are now the moisture content in that room.

If you really want to dry the room crack the window. The cooler 50-degree air outside has a much lower moisture compared to indoor air. Like temperature, moisture moves from areas of higher concentration to lower, seeking equilibrium. When the warmer indoor air mixes with, the cooler outdoor air, the result is a moderated temperature and reduced moisture level inside the room.

## HOW WE USED TO DO IT NO LONGER APPLIES

So, back in the day, we had this habit of using plastic sheets for vapor control. In hindsight? Not the best move for those homes. Here's the thing: when you use this kind of poly on the inside of walls, you might as well be setting up a sauna. There's this pesky issue where moisture sneaks in, and then it's like, "Nope, I'm comfy. Not leaving!" We've even got pictures of condensation forming behind these walls. The ironic thing? Poly was great at keeping the air out. But for managing vapor? Not so much. We've moved past recommending that.

## CONCLUSION

Vapor's everywhere, and it's always looking to balance itself out. You've probably caught on by now that it moves from higher to lower concentration areas, much like how we experience temperatures. Remember the hot, humid New Orleans on the Fourth of July? That's vapor at its peak, and when it condenses, we start sweating.

## THAT'S JUST HOW IT'S DONE

*Funny story - not long ago, I chatted with a builder who was dead set on using poly on the ceiling. I was like, "Why, though?" His reply? "That's just how it's done." I pointed out we were going with a vented roof system that lets outside air in, snags the moisture, and then sends it packing. He agreed, even mentioning the soffit vents and ridge vents in place. But then, I threw him a curveball, asking if he really got the whole point of a vented roof. Man, did he get defensive! He argued that the vented roof was to boot out any moisture. I tried to get him to see that if he believed in the magic of vented roofs, why slap on an extra barrier? But some folks just dig their heels in, you know? He wasn't having any of it and just hung up.*

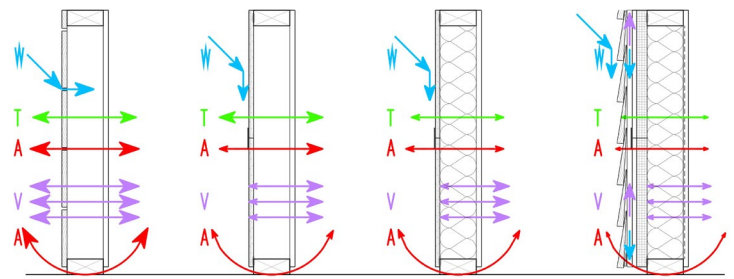

© Build Productions LLC 2023

Now, don't get spooked by vapor in buildings. It's not the Big Bad Wolf some make it out to be. Instead, it's all about managing it right. The gist is it's not about vapor being inherently wrong. It's about understanding how it impacts our structures. Think of moisture as a uniform force, evenly spread out, not zeroing in on a single spot. Those smart vapor retarders we talked about, they're like the techy guardians, ensuring moisture doesn't overstay its welcome.

Also, a tip for those of you in construction: you want to dry out a room after plastering? Just crack open a window. It's more effective than heating things up and adding to the humidity. And speaking of past practices, remember those plastic sheets? Not our finest moment in building science. We've learned, evolved, and now understand better materials and methods.

Last but not least, let's not get stuck in old ways just because "that's how we do it." We've got to be open to understanding the why behind our methods. Trust the science and expertise, and let's build smarter and drier.

Next up is thermal control—the last chapter in our 10-part series.

**THINK YOU KNOW A THING OR TWO ABOUT VAPOR? TAKE THE QUIZ TO FIND OUT AND EARN YOUR CERTIFICATE!**

**TAKE QUIZ**





# Chapter 10

## WRAPPING UP WITH THERMAL MANAGEMENT

We're approaching the end of Build Science™ 101. This last chapter discusses thermal management—more commonly known as insulation. This topic is one of the easiest to discuss because it is probably the most well-known conversation for the public.

### RECOGNIZING THERMAL MANAGEMENT

Thermal management resides in the fourth position of the four control layers. While insulation can play a major role in controlling comfort and energy efficiency, history suggests that little to no insulation is the reason for the success of long-lasting buildings. Old buildings were simple. We injected a lot of heat into them and baked them so that the drying potential significantly outweighed the wetting potential. And they lasted.

This is the last module for a reason. The other levels are the most important when it comes to the longevity of a building and the health of your wallet as a builder. On the other hand, insulation is likely the most regulated. There isn't a building inspector out there who doesn't know the exact values needed to take thermal control of your building.

These values are noted on nearly all materials related to thermal control.

WATCH THE FULL EPISODE HERE:

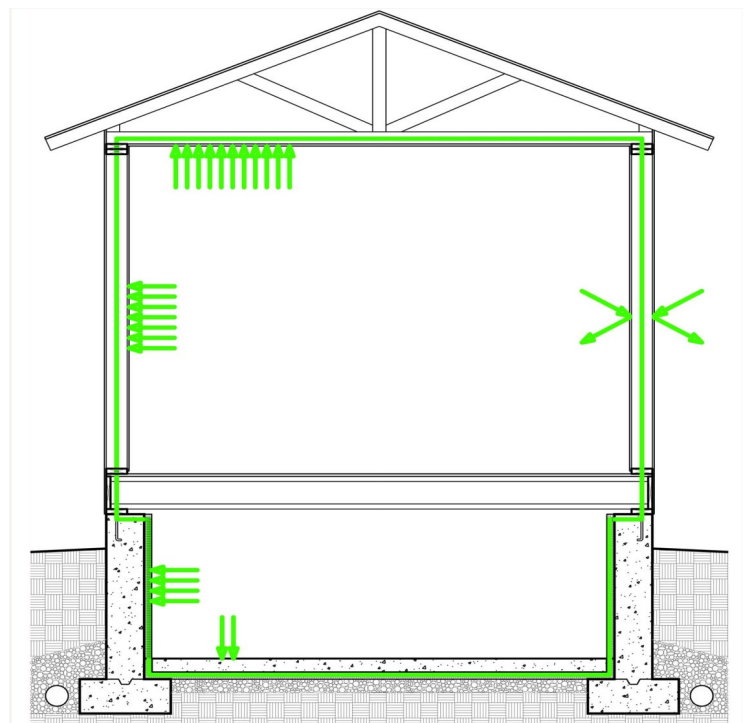

Images on this page © Build Productions LLC 2023



When the building inspector wants to know the U-value of your windows, it's on the sticker on the windows, and the R-value is right on the insulation.

So, at a basic level, what does insulation do? When it's 70 degrees inside and 0 degrees outside, heat moves from high to low because it's trying to make its way out of the wall assembly. When it's 100 degrees outside and 70 degrees inside, it's attempting to make its way through my assembly to the inside. Persistently, the temperature is always seeking equalization. To maintain level efficiency, we need to provide a level of resistance to the heat across the building assemblies (regardless of direction).

Like all the control layers, for insulation to be effective, it needs a high degree of continuity. Imagine going out into a snowstorm with a hat, jacket, and gloves on, but you're barefoot. Buildings are analogous to our bodies. In cold weather, we want to be warm—everywhere. When it's hot, we want to be cool—everywhere. Thermal management is about continuity. Like the Red Line Test of the air barrier system, the thermal control system could be tested in the same fashion. A pen placed on any building section drawing should trace the insulation components of the section, and the boundary should be a closed line.

## UNDERSTANDING THERMAL RESISTANCE

As mentioned, heat moves from hot to cold and is searching for equalization. In cold climates, generated heat inside a building tries to equalize across the building assemblies with the cooler temperatures outside. In warm climates, the heat outside tries to equalize across the building assemblies with cooler interior temperatures. ONLY HEAT MOVES. To resist heat movement, insulation is added to building assemblies as the resistance to heat flow.

Typically, this resistance is measured in R-value (R is the resistance level). The higher the number, the higher the resistance of the insulated assembly. Here's where the second part of the energy efficiency equation comes into play—after converting energy into heating or cooling – you want to hold onto it as long as you can. This premise is based on the resistance to heat transfer—or lack thereof.

While we want to maintain the continuity of thermal management, our assemblies' resistance levels should be in proportion. This is a two-fold suggestion. First, the level of thermal resistance should be tuned to the climate the building is exposed to. Very cold places should receive high levels of resistance. Second, the thermal resistance of the building assemblies should be tuned to the specific areas they are challenged by. For example, the under-slab insulation levels in a basement should be adjusted to the lower temperature delta of the ground below and the conditioned space above. Likewise, an above-grade wall, with a higher temperature delta between the outside and the inside conditioned space, should be tuned higher than its under-slab counterpart.

## CAVITY R-VALUE VS. WHOLE WALL R-VALUE

Sitting down at a table with three builders, Builder Number One is asked what kind of houses he builds. "Thermal," he says. "We build R-21 walls". Builder Number Two claims to build an enhanced wall system that builds right around R-30. Even before being asked, Builder Number Three throws out his chest and says, "I build nothing less than an R-48 wall." Now, ask them to prove it.

When we look at the components of a wall encompassing stud work, cavity insulation, and a window, we have a three-part wall system, right?

The opaque area is where the stud framing is. This area between the stud frame is known as the cavity area. It is where we typically install insulation. Within the wall is typically an area for windows and doors.

The cavity area is where builders are telling the truth. So, when they say R-21, R-32, or R-48, what they're citing is the center of cavity (COC) R-Value. As we march across that wall system, we'll see that approximately 20% (percentage may vary) of the wall system is windows and doors in this house. Whether advanced or not, the framing is at about 15%. (plus or minus 5%) That's roughly 35%. So that means the remaining cavity now is 65% . of the whole wall. So, when the builders say they're building R-21, R-32, and R-48, they're really suggesting what they fill the cavity with. (65% of the wall)

The reality is the center of the cavity is not the whole system. The last piece is that we can't enhance the windows by adding something. I will need to swap them out and buy a better window. You can get triple-glazed windows from domestic manufacturers. They're all around, but check out the U-value. There is something that can be done to further enhance the performance of stud framing and cavity insulation.

Imagine a wall system with exterior sheathing on the stud frame. Slap on one inch of rigid outside the stud framing and see the magic happen. The 2x6 stud's R-value of roughly R-6 can effectively double the R-value by adding the rigid insulation. Now, the 15% of stud frames have approximately doubled in performance. The cavity, which was at R-21, is roughly R-27. If we combine the 15% of

the stud frame area and 65% of the cavity area, we have effectively enhanced the performance of upwards of 80% of the wall assembly. The exterior rigid insulation, because of its continuity over the cavity and stud frame, enhances the wall everywhere there is no window or door.

In a casual conversation as a young architect, Steve once asked a very prominent North American building scientist, "whats the secret sauce to building the best wall assembly?" His answer was quite simple but profound, " Put as much insulation as you can afford outside the building, frame and you will be building the best wall. "

## CAVITY VS. CONTINUOUS - "THE SWEATER"

Let's think a little further about exterior insulation: imagine gearing up for a ski trip. If you're cold, would you try stuffing insulation between your ribs or simply pulling on a sweater? Of course, we're not suggesting insulation between studs isn't useful. Yet, for the benefit of a building, draping it with an "external sweater" is particularly effective in chilly climates. This approach ensures the whole structure remains warm. So, even if there were a mishap, like air leaks or potential moisture accumulation in the wall cavities, there'd be no cold spots for condensation to form. That external "sweater" means a toastier interior.

But let's up the ante a bit. If thermal control is our endgame, consider that external insulation a top-notch Build Show™ work jacket.



Alone, a sweater might let in cold air, quickly chilling you to the bone. However, throw on that Patagonia jacket, and voilà! It repels water, blocks icy winds, and preserves the warmth of the sweater. Together, they provide solid thermal resistance, ensuring a cozy indoor atmosphere.

## DECODING U-FACTORS AND R-VALUES

U-factors and R-values are energy efficiency indicators, but they measure differently. The U-factor gauges how effectively heat travels through a material, while the R-value quantifies resistance to heat flow. These values are reciprocal of each other. A lower U-factor and a higher R-value indicate superior insulation.

Now, why do we use U-factors for windows? Windows are complex. They consist of frames, glazing units, spacers, and sometimes even plastic components; they're more than just sheets of glass. Measuring the R-value of such an assembly is akin to assessing the insulating quality of a Build Show™ shirt after layering it with a sweater and a jacket. Sure, the Build Show™ shirt has its own heat resistance, but once you add more layers, the cumulative effect is what counts. That's why window assemblies opt for U-factor measurements.

Insulation, on the other hand, is straightforward. A sample is placed in a controlled environment to assess its effectiveness, and its resistance to heat flow is measured. Being tested solely allows you to attach an R-value to insulation.

Lastly, there's the concept of thermal conductivity. It defines how well a material conducts heat. High thermal conductivity is undesirable for insulation purposes because a material that conducts heat efficiently will result in greater/faster heat loss.



### The following formula is used to calculate the R-value:

$$R\text{-value} = \text{thickness of the insulation} / \lambda\text{-value}$$

The better the insulating material, the thinner the layer of insulation needs to be to arrive at the same result in terms of thermal insulation.

### The U-value is the opposite of the R-value (reciprocal) and the formula is:

$$U = 1/R, \text{ and an } R\text{-value of } 2 \text{ corresponds to a } U\text{-value of } 1/2 = 0.5.$$

### The U-value can be calculated using the $\lambda$ -value and the following formula:

$$U\text{-value} = \lambda\text{-value} / \text{thickness of the insulation}$$

**Today, a good U-value for replacement windows is anything below 2.0**

**The lower the U value and the higher the R-value, resulting in better performance**

## MYTH BUSTING: THE "GREEN LINE TEST"

Revisiting our earlier discussion on air tightness, continuity is just as essential in insulation as in ensuring an airtight seal. Think of it this way: If we trace an unbroken "green line" around an assembly, much like the "red line test" for air tightness, we should confidently cover the entire structure with insulation.

However, installing a window can disrupt several elements of the building envelope, including the thermal barrier. This makes the window and its surrounding components integral to the overall thermal management system. Understanding that thermal management isn't just about the insulation is crucial. At various points in the wall, elements like the studs, king, and jack frame might not be insulated, but they still have thermal properties. Simply saying, "put R-21 in the wall," oversimplifies the situation. What about the areas where the wall ends? Or the insulation under the slab? These might not have the same thermal qualities as wall insulation.

Like all home construction decisions, it's essential to tailor the thermal management system to the climate and the specific assembly requirements.



## CONCLUSION

Building a house isn't just about stacking bricks and hammering in nails. It's an intricate dance of physics, materials, and environmental factors, each contributing to the result – a comfortable, energy-efficient home that gives you control over your space. When three builders sit down and start tossing around R-values, it's easy to get lost in the numbers. But remember, these numbers don't quite tell the entire story.

The true narrative is woven into the very fabric of the house: in the continuity of insulation, the quality of windows, the placement of studs, and the intricate dance between U-factors and R-values. Think about those windows for a moment. Yes, they let in the sunshine and frame beautiful views, but they're also integral to a home's thermal management system. They must be considered alongside every piece of insulation and every inch of stud work.

This journey through the realm of insulation has debunked a few myths along the way. For instance, stuffing insulation between studs, while important, isn't the be-all and end-all. The real secret? Wrapping a house in as much insulation as one can afford – essentially gifting it with an external “sweater,” or better yet, a Build Show™ jacket.

Deciphering the codes of U-factors and R-values can feel like learning a new language, but the principles are clear. A lower U-value and a higher R-value? That's like hitting the energy efficiency jackpot. And let's not forget our “green line test.” It reinforces the need for continuity, ensuring a building is wrapped up snugly from all sides.

To round things up, when building a home, it's crucial to tune into both the climate and the assembly's specific needs. In doing so, not only do we construct houses that stand strong against the elements, but we also craft homes that envelop their occupants in comfort. Remember, in the grand scheme of things, every detail counts. And with every decision made, a warmer, more energy-efficient home awaits.

**THINK YOU KNOW A THING OR TWO ABOUT THERMAL MANAGEMENT? TAKE THE QUIZ TO FIND OUT AND EARN YOUR CERTIFICATE!**

**TAKE QUIZ**



# About the Build Show™

The mission of The Build Show™ is to elevate the standards of the building industry through education and practice. Through our videos, podcasts and training, our viewers can explore the art behind building science and quality craftsmanship, view detailed product reviews, and get advice on which strategies to consider for their building and remodeling projects.

Matt Risinger and the team of Build Show™ Experts are practitioners who have built architecturally driven homes that meet the highest standards of craftsmanship, durability, efficiency and comfort. As host of the “Build Show™” Matt has become a nationally recognized expert in building science and high-performance construction.

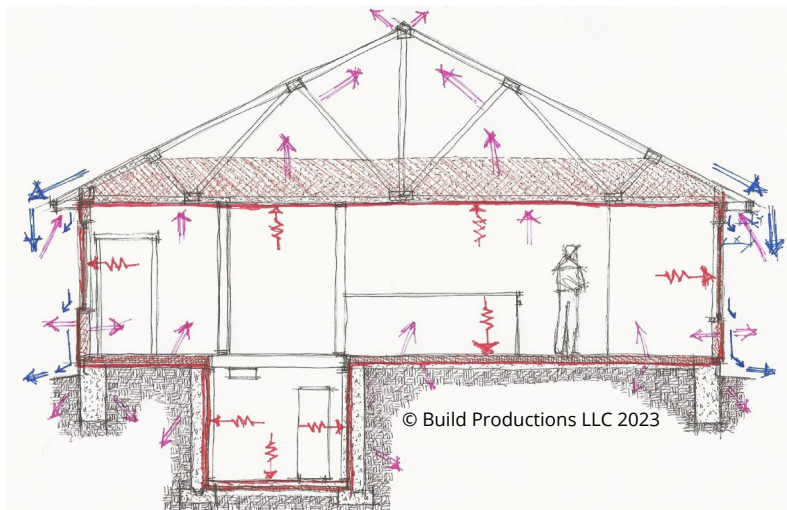

## MATT RISINGER

is the creator and founder of *The Build Show™*, *thebuildshow.com* and CEO of Risinger Build. Matt's passion for building high performance homes and building science education ignited the formation of The Build Show™ website, (*thebuildshow.com*) a trusted building science destination for builders, contractors, remodelers and DIYers. Matt's successful Build Show™ YouTube channel has grown to a loyal 1million+ followers, and recognition as an industry influencer. Through The Build Show™ platforms, Matt shares his extensive knowledge of building science, educating the community by providing techniques and hands-on learning from his personal experiences—in partnership with *thebuildshow.com* network of highly regarded industry experts. In 2021, Matt launched the highly successful Build Podcast, consistently ranked in the top 15. Matt is a highly sought after speaker and advisor on high performance building in the residential construction industry.



## STEVE BACZEK

Steve is a registered architect and member of The Build Show™ expert team with over 30 years of residential construction industry experience. Utilizing his strong Building Science background in building custom homes, Steve strives to integrate sound design practices with good construction practices to provide exceptional design solutions. His new construction projects range from over 50 Leed Platinum Homes to Zero Energy Homes, and numerous Certified Passive Homes.

Steve also takes on renovation projects designed to be Zero Energy, Deep Energy Retrofits, as well as the first Certified Passive House Renovation in the U.S. under the “Enerphit” program. My association with the Architecture Profession and Residential Construction Industry goes beyond his practice – he routinely volunteers as an Architecture Critic at a School of Architecture.