



**Boise Cascade**  
*Engineered Wood Products*

# WESTERN COMMERCIAL GUIDE

for products manufactured in White City, Oregon and Homedale, Idaho



# The SIMPLE FRAMING SYSTEM<sup>®</sup> Makes Designing Homes Easier

Architects, engineers, and designers trust  
Boise Cascade's engineered wood products to  
provide a better system for framing floors and roofs.

## Boise Cascade Engineered Wood Products for Light Commercial Applications

Boise Cascade Engineered Wood Products are readily available through experienced distributors and retailers who provide valuable assistance in selecting and specifying the most economical joist and beam system. By specifying the products shown in the guide, time delays associated with so-called custom products from other manufacturers are minimized. While those products may be structurally adequate, they are only available on a "build to order" basis. That means your clients have automatically just added a minimum of 2-3 weeks to their production cycle: an eternity in today's tight construction schedules. Add that same amount of time for a single mis-cut joist and you can certainly see how quickly a well-intended specification can turn into a logistical nightmare.

This design guide is intended to provide information for the preliminary sizing of Boise Cascade Engineered Wood Products. While the products and applications shown in this guide are similar to our residential applications guide, the building code provisions and design requirements of the light commercial projects are significantly different. Concentrated floor load provisions, partition loads, wind and seismic provisions, and fire protection systems are all examples of these differences. This guide helps identify these issues and provides corresponding product application details. Professional guidelines in most areas require the project's design professional of record to be responsible for the overall design

of light commercial structures. This guide is intended to assist the design professional in specifying engineered wood products in dry-use condition of such structures.

BCI<sup>®</sup> joists and VERSA-LAM<sup>®</sup> beams are manufactured per corresponding International Code Council building code evaluation reports. Testing and quality control is certified by an independent inspection agency. Boise Cascade Engineered Wood Products are warranted for the life of the structure (see back cover of this guide). For the location of the nearest Boise Cascade representative or supplier of Boise Cascade Engineered Wood Products, please call 800-232-0788.

For complete information on fire resistance detailing and design with the entire Boise Cascade EWP product line, please refer to the US Fire Design & Installation Guide, located at [www.bc.com/ewp](http://www.bc.com/ewp).

Product Profiles, BCI <sup>®</sup> Specifications .....	3	VERSA-LAM <sup>®</sup> Non-Snow Roof Load Tables (125% Load Duration) .....	42
40 PSF - 100 PSF Live/Concentrated Load Span Tables .....	4 - 13	VERSA-LAM <sup>®</sup> Closest Allowable Nail Spacing .....	43
BCI <sup>®</sup> Floor Framing Details .....	14 - 17	VERSA-LAM <sup>®</sup> Design Values .....	43
BCI <sup>®</sup> Joist Hole Location and Sizing .....	18	VERSA-LAM <sup>®</sup> Columns, VERSA-STUD <sup>®</sup> .....	44
BCI <sup>®</sup> Cantilever Details, Web Stiffener Requirements .....	19	BOISE GLULAM <sup>®</sup> Beams .....	45
BCI <sup>®</sup> Floor Load Tables .....	20 - 22	BOISE GLULAM <sup>®</sup> Information .....	46
BCI <sup>®</sup> Roof Framing Details .....	23 - 24	BOISE GLULAM <sup>®</sup> Custom Products .....	47
BCI <sup>®</sup> Roof Span Tables .....	25 - 29	BOISE GLULAM <sup>®</sup> Design Values - 24F-V4, 26F-V1 .....	48 - 50
BCI <sup>®</sup> Roof Load Tables .....	30 - 34	BOISE GLULAM <sup>®</sup> IJC Design Values - 24F-V4, 26F-V1 .....	51
BCI <sup>®</sup> Design Properties, BCI <sup>®</sup> Allowable Nail Spacing .....	35	KING BEAM <sup>™</sup> 3000 Design Values .....	52
Boise Cascade Rimboard Products .....	36	BOISE CEDAR GLULAM <sup>™</sup> Design Values .....	53
VERSA-LAM <sup>®</sup> Products, Specifications, Allowable Holes .....	37	BOISE GLULAM <sup>®</sup> Column Table & Allowable Stresses .....	54
VERSA-LAM <sup>®</sup> Details, Multiple Member Connectors .....	38	BOISE GLULAM <sup>®</sup> Beams Hanger Tables .....	55 - 56
VERSA-LAM <sup>®</sup> Allowable Floor Joist Spans .....	39	Computer Software .....	57
VERSA-LAM <sup>®</sup> Floor Load Tables (100% Load Duration) .....	40	Framing Connectors .....	58 - 59
VERSA-LAM <sup>®</sup> Snow Roof Load Tables (115% Load Duration) .....	41	Lifetime Guarantee .....	Back Cover

## BCI® Joists

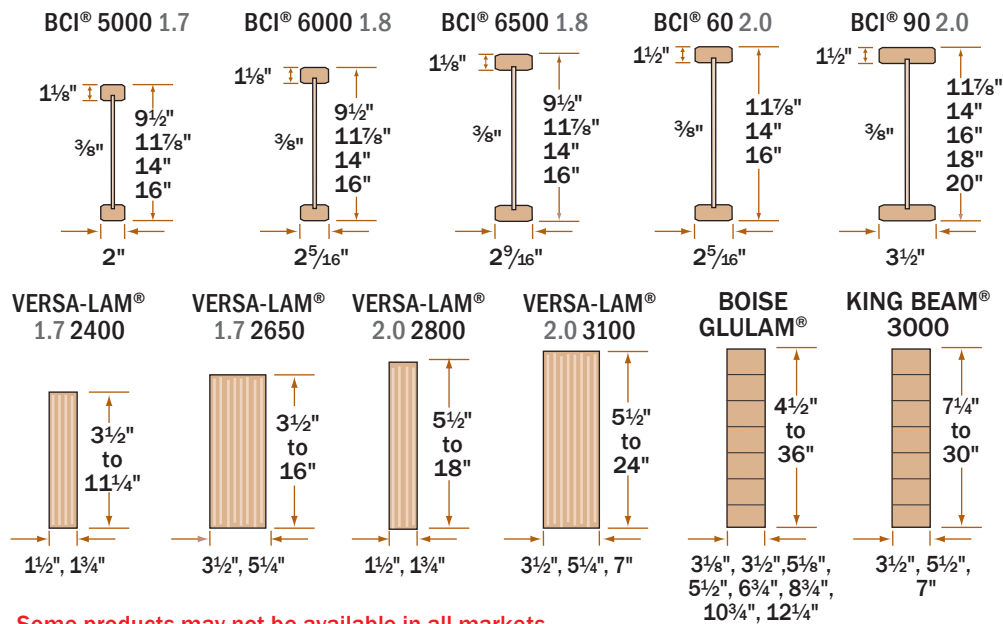

Some products may not be available in all markets.  
 Contact your Boise Cascade EWP representative for availability.  
 Deeper BOISE GLULAM® and KING BEAM® 3000 sections are available on a custom-order basis.



## BCI® Joist Architectural Specifications

**Scope:** This work includes the complete furnishing and installation of all BCI® Joists as shown on the drawings, herein specified and necessary to complete the work.

**Materials:** BCI® Joists shall be manufactured by Boise Cascade Engineered Wood Products with oriented strand board webs, VERSA-LAM® laminated veneer lumber flanges and waterproof, structural adhesives.

Joist webs shall be graded Structural I Exposure 1 by an agency listed by a model code evaluation service. Strands on the face layers of the web panels shall be oriented vertically in the joist. The web panels shall be glued together to form a continuous web member. The web panels shall be machined to fit into a groove in the center of the wide face of the flange members so as to form a pressed glue joint at that junction.

**Design:** The BCI® Joists shall be sized and detailed to fit the dimensions and loads indicated on the plans. All designs shall be in accordance with allowable values and section properties developed in accordance with ASTM D5055 and listed in the governing code evaluation service's report.

**Drawing:** Additional drawings showing layout and detail necessary for determining fit and placement in the building are (are not) to be provided by the supplier.

**Fabrication:** The BCI® Joists and section properties shall be manufactured in a plant evaluated for fabrication by the governing code evaluation service and under the supervision of a third-party inspection agency listed by the corresponding evaluation service.

**Storage and Installation:** The BCI® Joists, if stored prior to erection, shall be stored in a vertical and level position and protected from the weather. They shall be handled with care so they are not damaged.

The BCI® Joists are to be installed in accordance with the plans and the Boise Cascade Engineered Wood Products Installation Guide. Temporary construction loads which cause stresses beyond design limits are not permitted. Erection bracing shall be provided to keep the BCI® Joists straight and plumb as required and to assure adequate lateral support for the individual BCI® Joists and the entire system until the sheathing material has been applied.

**Codes:** The BCI® Joists shall be evaluated by a model code evaluation service.

**BCI Joists in Commercial Projects:** All commercial projects utilizing BCI® joists shall have an engineer or architect of record.

# 40 PSF Live Load Span Tables

## Multi-Family Dwellings and Hotels: Private Rooms No Web Stiffeners Required Except for 18" & 20" BCI® 90 Joists

40 PSF Live Load + 25 PSF Dead Load

Joist Depth	Joist Series	3½" Interior Bearing				5¼" Interior Bearing			
		12" o.c.	16" o.c.	19.2" o.c.	24" o.c.	12" o.c.	16" o.c.	19.2" o.c.	24" o.c.
9½"	BCI® 5000 1.7	17'-1"	14'-11"	13'-8"	12'-2"	17'-1"	14'-11"	13'-8"	12'-2"
	BCI® 6000 1.8	17'-11"	16'-5"	15'-6"	13'-10"	17'-11"	16'-5"	15'-6"	13'-10"
	BCI® 6500 1.8	18'-6"	16'-11"	15'-11"	14'-7"	18'-6"	16'-11"	15'-11"	14'-7"
11⅞"	BCI® 5000 1.7	19'-7"	16'-11"	15'-5"	13'-9"	19'-7"	16'-11"	15'-5"	13'-10"
	BCI® 6000 1.8	21'-3"	19'-3"	17'-7"	15'-3"	21'-3"	19'-3"	17'-7"	15'-8"
	BCI® 6500 1.8	21'-11"	20'-0"	18'-6"	15'-3"	21'-11"	20'-0"	18'-6"	16'-6"
	BCI® 60 2.0	23'-3"	21'-3"	20'-1"	16'-10"	23'-3"	21'-3"	20'-1"	18'-8"
	BCI® 90 2.0	26'-3"	23'-11"	22'-7"	20'-8"	26'-3"	23'-11"	22'-7"	21'-0"
14"	BCI® 5000 1.7	21'-4"	18'-5"	16'-10"	14'-4"	21'-4"	18'-5"	16'-10"	15'-0"
	BCI® 6000 1.8	24'-3"	20'-11"	19'-1"	15'-11"	24'-3"	20'-11"	19'-1"	17'-1"
	BCI® 6500 1.8	24'-11"	22'-1"	19'-11"	15'-11"	24'-11"	22'-1"	20'-1"	17'-11"
	BCI® 60 2.0	26'-6"	24'-2"	21'-0"	16'-10"	26'-6"	24'-2"	22'-10"	19'-7"
	BCI® 90 2.0	29'-9"	27'-1"	25'-6"	20'-10"	29'-9"	27'-1"	25'-6"	23'-9"
16"	BCI® 5000 1.7	22'-9"	19'-8"	18'-0"	14'-8"	22'-9"	19'-8"	18'-0"	15'-5"
	BCI® 6000 1.8	25'-11"	22'-5"	20'-3"	16'-2"	25'-11"	22'-5"	20'-5"	18'-0"
	BCI® 6500 1.8	27'-3"	23'-7"	20'-3"	16'-2"	27'-3"	23'-7"	21'-6"	18'-0"
	BCI® 60 2.0	29'-3"	25'-3"	21'-0"	16'-10"	29'-3"	26'-8"	24'-6"	19'-7"
	BCI® 90 2.0	32'-11"	29'-11"	26'-3"	20'-11"	32'-11"	29'-11"	28'-3"	25'-0"
18"	BCI® 90 2.0	35'-11"	32'-8"	30'-10"	25'-5"	35'-11"	32'-8"	30'-10"	28'-8"
20"	BCI® 90 2.0	38'-10"	35'-4"	32'-11"	26'-4"	38'-10"	35'-4"	33'-4"	29'-9"

### NOTES

- Loading based upon Table 1607.1 of 2009 International Building Code
- Spans limited by allowable moment and reaction values, total load deflection of L/240. Live load deflection limited to L/480.
- Table values assume that 2<sup>3</sup>/<sub>32</sub>" min. plywood/OSB rated sheathing is glued and nailed to joists.
- Table values represent the most restrictive of simple or multiple span applications.
- Table values are the maximum allowable clear distance between supports.
- Table assumes minimum 2¼" end bearing. 18" & 20" BCI® 90 joists require web stiffeners at all bearing locations.
- This table was designed to apply to a broad range of applications. It may be possible to exceed the limitations of this table by analyzing a specific application with the BC CALC® sizing software.

## Medical/Dental: Private Rooms

### Web Stiffeners Required at All Bearing Locations for Table Below

Spans without web stiffeners and/or shorter bearings are possible, analyze such conditions with BC CALC<sup>®</sup> sizing software.

[Worst Case 40 PSF or 1000 LB Concentrated Live Load] + 25 PSF Dead Load					
Joist Depth	Joist Series	3½" Interior Bearing / 5¼" Interior Bearing			
		12" o.c.	16" o.c.	19.2" o.c.	24" o.c.
9½"	BCI <sup>®</sup> 5000 1.7	15'-10"	13'-6"	11'-10"	10'-0"
	BCI <sup>®</sup> 6000 1.8	16'-7"	15'-2"	14'-3"	12'-1"
	BCI <sup>®</sup> 6500 1.8	17'-1"	15'-7"	14'-8"	13'-0"
11⅞"	BCI <sup>®</sup> 5000 1.7	18'-8"	16'-2"	14'-2"	12'-0"
	BCI <sup>®</sup> 6000 1.8	19'-8"	18'-0"	16'-11"	14'-6"
	BCI <sup>®</sup> 6500 1.8	20'-3"	18'-6"	17'-6"	15'-7"
	BCI <sup>®</sup> 60 2.0	21'-6"	19'-8"	18'-6"	17'-3"
	BCI <sup>®</sup> 90 2.0	24'-3"	22'-1"	20'-10"	19'-4"
14"	BCI <sup>®</sup> 5000 1.7	21'-3"	18'-3"	16'-1"	13'-8"
	BCI <sup>®</sup> 6000 1.8	22'-5"	20'-6"	19'-1"	16'-5"
	BCI <sup>®</sup> 6500 1.8	23'-0"	21'-0"	19'-10"	17'-8"
	BCI <sup>®</sup> 60 2.0	24'-6"	22'-4"	21'-1"	19'-7"
	BCI <sup>®</sup> 90 2.0	27'-6"	25'-0"	23'-7"	21'-10"
16"	BCI <sup>®</sup> 5000 1.7	22'-9"	19'-8"	17'-8"	15'-0"
	BCI <sup>®</sup> 6000 1.8	24'-9"	22'-5"	20'-5"	18'-0"
	BCI <sup>®</sup> 6500 1.8	25'-5"	23'-2"	21'-6"	19'-3"
	BCI <sup>®</sup> 60 2.0	27'-1"	24'-8"	23'-3"	21'-8"
	BCI <sup>®</sup> 90 2.0	30'-5"	27'-8"	26'-1"	24'-2"
18"	BCI <sup>®</sup> 90 2.0	33'-3"	30'-2"	28'-5"	25'-5"
20"	BCI <sup>®</sup> 90 2.0	35'-11"	32'-8"	30'-9"	26'-4"

#### NOTES

- Loading based upon Table 1607.1 of 2009 International Building Code
- Spans limited by allowable moment and reaction values, total load deflection of L/240. Live load deflection limited to L/480 with 40 psf.
- Table values assume that 23/32" min. plywood/OSB rated sheathing is glued and nailed to joists.
- Table values represent the most restrictive of simple or multiple span applications.
- Table values are the maximum allowable clear distance between supports.
- Table values assume web stiffeners at each bearing location, minimum 2¼" end bearing.
- This table was designed to apply to a broad range of applications. It may be possible to exceed the limitations of this table by analyzing a specific application with the BC CALC<sup>®</sup> sizing software.
- School and essential service projects in California (DSA) require additional design provisions and thus the above span length limits may not apply. Contact Boise Cascade EWP Engineering for further information.

## Concentrated Live Loads ("Safe" Loads)

The International Building Code requires certain types of commercial floors to be designed with a concentrated live load, in addition to the prescribed uniform loads. This concentrated live load is applied to the floor without the uniform live load but with all dead load, creating a separate live load analysis. The concentrated load is either 2000 lb or 1000 lb, depending upon the floor type, and is applied to a 2½ foot x 2½ foot square area. This 2½-foot square is applied on the floor such that would result in the highest shear and bending stress, and deflections. Since this load is intended to create maximum stress and deflection conditions, it is centered over a specific floor joist. Floor joists at 24" on-center will receive more

load from the concentrated live load than joists spaced at smaller increments. For example, a joist at 24" on-center will receive 2/2.5 or 80% of the concentrated load over a distance of 2'-6" along the joist length.

*There have been some misconceptions in the design community on how the concentrated live load should be applied to floors. Boise Cascade EWP Engineering has consulted directly with ICC on this matter. The loads prescribed in section 1607.4 of the 2009 IBC have been properly considered in the development of the relative floor joist tables in this guide.*

# 50 PSF Live, 15 PSF Partition & 2000 lb Conc. Load Span Tables

[Worst Case 50 PSF or 1000 LB Concentrated Live Load] +  
15 PSF Partition Load + 25 PSF Dead Load  
Office Buildings: Office Area

## Web Stiffeners Required at All Bearing Locations for Table Below

Spans without web stiffeners and/or shorter bearings are possible, analyze such conditions with BC CALC® sizing software.

[Worst Case 50 PSF or 1000 LB Concentrated Live Load] + 15 PSF Partition Load + 25 PSF Dead Load									
Joist Depth	Joist Series	3½" Interior Bearing				5¼" Interior Bearing			
		12" o.c.	16" o.c.	19.2" o.c.	24" o.c.	12" o.c.	16" o.c.	19.2" o.c.	24" o.c.
9½"	BCI® 5000 1.7	11'-3"	8'-11"	6'-8"	3'-9"	11'-3"	8'-11"	6'-8"	3'-9"
	BCI® 6000 1.8	13'-9"	10'-11"	9'-5"	5'-7"	13'-9"	10'-11"	9'-5"	5'-7"
	BCI® 6500 1.8	14'-11"	11'-10"	10'-3"	5'-7"	14'-11"	11'-10"	10'-3"	5'-7"
11⅞"	BCI® 5000 1.7	13'-8"	10'-11"	9'-5"	6'-3"	13'-8"	10'-11"	9'-5"	6'-3"
	BCI® 6000 1.8	16'-9"	13'-4"	11'-6"	6'-3"	16'-9"	13'-4"	11'-6"	6'-3"
	BCI® 6500 1.8	18'-2"	14'-6"	12'-6"	6'-3"	18'-2"	14'-6"	12'-6"	6'-3"
	BCI® 60 2.0	19'-11"	18'-2"	13'-10"	6'-3"	19'-11"	18'-2"	13'-10"	6'-3"
	BCI® 90 2.0	22'-5"	20'-4"	19'-2"	16'-3"	22'-5"	20'-4"	19'-2"	16'-3"
14"	BCI® 5000 1.7	15'-8"	12'-6"	10'-9"	8'-10"	15'-8"	12'-6"	10'-9"	8'-10"
	BCI® 6000 1.8	19'-2"	15'-3"	13'-3"	8'-10"	19'-2"	15'-3"	13'-3"	8'-10"
	BCI® 6500 1.8	20'-9"	16'-7"	14'-4"	8'-10"	20'-9"	16'-7"	14'-4"	8'-10"
	BCI® 60 2.0	22'-7"	20'-7"	18'-8"	8'-10"	22'-7"	20'-7"	18'-8"	8'-10"
	BCI® 90 2.0	25'-5"	23'-1"	21'-3"	17'-0"	25'-5"	23'-1"	21'-8"	19'-8"
16"	BCI® 5000 1.7	17'-5"	13'-10"	12'-0"	10'-0"	17'-5"	13'-10"	12'-0"	10'-0"
	BCI® 6000 1.8	21'-3"	17'-0"	14'-8"	12'-3"	21'-3"	17'-0"	14'-8"	12'-3"
	BCI® 6500 1.8	23'-0"	18'-5"	15'-11"	12'-6"	23'-0"	18'-5"	15'-11"	12'-6"
	BCI® 60 2.0	25'-0"	22'-9"	20'-2"	12'-6"	25'-0"	22'-9"	20'-8"	12'-6"
	BCI® 90 2.0	28'-1"	25'-6"	22'-1"	17'-8"	28'-1"	25'-6"	24'-0"	20'-7"
18"	BCI® 90 2.0	30'-8"	27'-7"	22'-11"	18'-4"	30'-8"	27'-10"	26'-3"	21'-0"
20"	BCI® 90 2.0	33'-2"	28'-7"	23'-9"	19'-0"	33'-2"	30'-2"	26'-10"	21'-5"

### NOTES

- Loading based upon Table 1607.1 of 2009 International Building Code
- Spans limited by allowable moment and reaction values, total load deflection of L/240. Live load deflection limited to L/600 with 50 psf, L/360 with 50 + 15 psf.
- Table values assume that 23/32" min. plywood/OSB rated sheathing is glued and nailed to joists.
- Table values represent the most restrictive of simple or multiple span applications.
- Table values are the maximum allowable clear distance between supports.
- Table values assume web stiffeners at each bearing location, minimum 2¼" end bearing.
- This table was designed to apply to a broad range of applications. It may be possible to exceed the limitations of this table by analyzing a specific application with the BC CALC® sizing software.
- School and essential service projects in California (DSA) require additional design provisions and thus the above span length limits may not apply. Contact Boise Cascade EWP Engineering for further information.

### Deflection Criteria for Commercial Floors

The minimum deflection criterion for commercial floors is the same as for residential floors, L/360 for live load deflection and L/240 for total load deflection. Since deflection controls a significant amount of I-joist designs, an additional deflection limit has been considered in the development of the BCI® joist span tables shown in this guide. In addition to the minimum limits at full uniform and concentrated ("safe") live loads, deflection is limited to L/600 with a uniform live load of 50 psf in those tables where the code specified uniform live load is 50 psf or greater. As is the case with all joist designs, floor performance should always be considered by the design professional of record in each specific condition.

Medical/Dental: Operating Rooms & Laboratory  
Library: Reading Rooms

[Worst Case 60 PSF or 1000 LB Concentrated Live Load] + 25 PSF Dead Load

Joist Depth	Joist Series	3½" Interior Bearing				5¼" Interior Bearing			
		12" o.c.	16" o.c.	19.2" o.c.	24" o.c.	12" o.c.	16" o.c.	19.2" o.c.	24" o.c.
9½"	BCI® 5000 1.7	14'-7"	13'-1"	11'-10"	10'-0"	14'-7"	13'-1"	11'-10"	10'-0"
	BCI® 6000 1.8	15'-4"	14'-0"	13'-2"	12'-1"	15'-4"	14'-0"	13'-2"	12'-1"
	BCI® 6500 1.8	15'-9"	14'-4"	13'-7"	12'-4"	15'-9"	14'-4"	13'-7"	12'-7"
11⅞"	BCI® 5000 1.7	17'-1"	14'-9"	13'-6"	12'-0"	17'-1"	14'-9"	13'-6"	12'-0"
	BCI® 6000 1.8	18'-2"	16'-7"	15'-4"	13'-3"	18'-2"	16'-7"	15'-4"	13'-8"
	BCI® 6500 1.8	18'-9"	17'-1"	16'-2"	13'-3"	18'-9"	17'-1"	16'-2"	14'-0"
	BCI® 60 2.0	19'-11"	18'-2"	16'-8"	13'-3"	19'-11"	18'-2"	17'-1"	15'-2"
14"	BCI® 90 2.0	22'-5"	20'-4"	19'-2"	17'-3"	22'-5"	20'-4"	19'-2"	17'-9"
	BCI® 5000 1.7	18'-7"	16'-1"	14'-8"	13'-2"	18'-7"	16'-1"	14'-8"	13'-2"
	BCI® 6000 1.8	20'-9"	18'-4"	16'-8"	14'-8"	20'-9"	18'-4"	16'-8"	14'-11"
	BCI® 6500 1.8	21'-3"	19'-3"	17'-7"	14'-8"	21'-3"	19'-3"	17'-7"	14'-11"
16"	BCI® 60 2.0	22'-7"	20'-7"	19'-5"	16'-1"	22'-7"	20'-7"	19'-5"	17'-1"
	BCI® 90 2.0	25'-5"	23'-1"	21'-8"	18'-0"	25'-5"	23'-1"	21'-8"	20'-2"
	BCI® 5000 1.7	19'-11"	17'-3"	15'-8"	14'-0"	19'-11"	17'-3"	15'-8"	14'-0"
	BCI® 6000 1.8	22'-7"	19'-7"	17'-10"	15'-8"	22'-7"	19'-7"	17'-10"	15'-8"
	BCI® 6500 1.8	23'-6"	20'-7"	18'-10"	15'-8"	23'-6"	20'-7"	18'-10"	15'-8"
18"	BCI® 60 2.0	25'-0"	22'-9"	21'-4"	17'-1"	25'-0"	22'-9"	21'-6"	17'-6"
	BCI® 90 2.0	28'-1"	25'-6"	23'-5"	18'-8"	28'-1"	25'-6"	24'-0"	21'-9"
20"	BCI® 90 2.0	30'-8"	27'-10"	24'-3"	19'-5"	30'-8"	27'-10"	26'-3"	22'-3"
20"	BCI® 90 2.0	33'-2"	30'-2"	25'-2"	20'-1"	33'-2"	30'-2"	28'-4"	22'-8"

**Web Stiffeners Required at All Bearing Locations for Table Below**  
Spans without web stiffeners and/or shorter bearings are possible, analyze such conditions with BC CALC® sizing software.

**NOTES FOR BOTH TABLES**

- Loading based upon Table 1607.1 of 2009 International Building Code.
- Spans limited by allowable moment and reaction values, total load deflection of L/240. Live load deflection limited to L/600 with 50 psf and L/360 with listed uniform live load.
- Table values assume that 23/32" min. plywood/OSB rated sheathing is glued and nailed to joists.
- Table values represent the most restrictive of simple or multiple span applications.
- Table values are the maximum allowable clear distance between supports.
- Table values assume web stiffeners at each bearing location, minimum 2¼" end bearing.
- This table was designed to apply to a broad range of applications. It may be possible to exceed the limitations of this table by analyzing a specific application with the BC CALC® sizing software.
- School and essential service projects in California (DSA) require additional design provisions and thus the above span length limits may not apply. Contact Boise Cascade EWP Engineering for further information.

**Retail: Upper Floors**

[Worst Case 75 PSF or 1000 LB Concentrated Live Load] + 25 PSF Dead Load

Joist Depth	Joist Series	3½" Interior Bearing				5¼" Interior Bearing			
		12" o.c.	16" o.c.	19.2" o.c.	24" o.c.	12" o.c.	16" o.c.	19.2" o.c.	24" o.c.
9½"	BCI® 5000 1.7	13'-11"	12'-0"	11'-0"	9'-3"	13'-11"	12'-0"	11'-0"	9'-10"
	BCI® 6000 1.8	15'-4"	13'-8"	12'-5"	10'-6"	15'-4"	13'-8"	12'-5"	10'-11"
	BCI® 6500 1.8	15'-9"	14'-4"	13'-1"	10'-6"	15'-9"	14'-4"	13'-1"	10'-11"
11⅞"	BCI® 5000 1.7	15'-9"	13'-7"	12'-5"	11'-1"	15'-9"	13'-7"	12'-5"	11'-1"
	BCI® 6000 1.8	17'-11"	15'-6"	14'-1"	11'-3"	17'-11"	15'-6"	14'-1"	11'-11"
	BCI® 6500 1.8	18'-9"	16'-4"	14'-2"	11'-3"	18'-9"	16'-4"	14'-10"	11'-11"
	BCI® 60 2.0	19'-11"	17'-0"	14'-2"	11'-3"	19'-11"	18'-2"	16'-2"	12'-11"
14"	BCI® 90 2.0	22'-5"	20'-4"	18'-5"	14'-8"	22'-5"	20'-4"	19'-2"	17'-1"
	BCI® 5000 1.7	17'-2"	14'-10"	13'-6"	12'-1"	17'-2"	14'-10"	13'-6"	12'-1"
	BCI® 6000 1.8	19'-6"	16'-10"	15'-5"	12'-6"	19'-6"	16'-10"	15'-5"	12'-8"
	BCI® 6500 1.8	20'-6"	17'-9"	15'-8"	12'-6"	20'-6"	17'-9"	15'-11"	12'-8"
16"	BCI® 60 2.0	22'-7"	20'-7"	17'-2"	13'-8"	22'-7"	20'-7"	18'-2"	14'-6"
	BCI® 90 2.0	25'-5"	23'-0"	19'-2"	15'-3"	25'-5"	23'-1"	21'-8"	17'-8"
	BCI® 5000 1.7	18'-4"	15'-10"	14'-6"	12'-8"	18'-4"	15'-10"	14'-6"	12'-11"
	BCI® 6000 1.8	20'-10"	18'-0"	16'-5"	13'-3"	20'-10"	18'-0"	16'-5"	13'-3"
	BCI® 6500 1.8	21'-11"	19'-0"	16'-8"	13'-3"	21'-11"	19'-0"	16'-8"	13'-3"
18"	BCI® 60 2.0	25'-0"	21'-9"	18'-2"	14'-6"	25'-0"	22'-5"	18'-8"	14'-11"
	BCI® 90 2.0	28'-1"	23'-11"	19'-11"	15'-11"	28'-1"	25'-6"	23'-2"	18'-6"
20"	BCI® 90 2.0	30'-8"	24'-9"	20'-8"	16'-6"	30'-8"	27'-10"	23'-8"	18'-11"
20"	BCI® 90 2.0	33'-2"	25'-8"	21'-5"	17'-1"	33'-2"	29'-0"	24'-2"	19'-3"

## Medical, Schools, Libraries: Upper Floor Corridors

[Worst Case 80 PSF or 1000 LB Concentrated Live Load] + 25 PSF Dead Load									
Joist Depth	Joist Series	3½" Interior Bearing				5¼" Interior Bearing			
		12" o.c.	16" o.c.	19.2" o.c.	24" o.c.	12" o.c.	16" o.c.	19.2" o.c.	24" o.c.
9½"	BCI® 5000 1.7	13'-7"	11'-9"	10'-8"	8'-10"	13'-7"	11'-9"	10'-8"	9'-7"
	BCI® 6000 1.8	15'-4"	13'-4"	12'-2"	10'-0"	15'-4"	13'-4"	12'-2"	10'-4"
	BCI® 6500 1.8	15'-9"	14'-0"	12'-6"	10'-0"	15'-9"	14'-0"	12'-10"	10'-4"
11⅞"	BCI® 5000 1.7	15'-4"	13'-3"	12'-1"	10'-9"	15'-4"	13'-3"	12'-1"	10'-10"
	BCI® 6000 1.8	17'-6"	15'-1"	13'-5"	10'-9"	17'-6"	15'-1"	13'-9"	11'-4"
	BCI® 6500 1.8	18'-5"	15'-11"	13'-5"	10'-9"	18'-5"	15'-11"	14'-2"	11'-4"
	BCI® 60 2.0	19'-11"	16'-2"	13'-5"	10'-9"	19'-11"	18'-2"	15'-4"	12'-3"
14"	BCI® 90 2.0	22'-5"	20'-4"	17'-6"	14'-0"	22'-5"	20'-4"	19'-2"	16'-3"
	BCI® 5000 1.7	16'-9"	14'-6"	13'-3"	11'-6"	16'-9"	14'-6"	13'-3"	11'-10"
	BCI® 6000 1.8	19'-0"	16'-6"	14'-11"	11'-11"	19'-0"	16'-6"	15'-0"	12'-1"
	BCI® 6500 1.8	20'-0"	17'-4"	14'-11"	11'-11"	20'-0"	17'-4"	15'-1"	12'-1"
	BCI® 60 2.0	22'-7"	19'-7"	16'-4"	13'-0"	22'-7"	20'-6"	17'-3"	13'-9"
16"	BCI® 90 2.0	25'-5"	21'-11"	18'-2"	14'-6"	25'-5"	23'-1"	21'-1"	16'-10"
	BCI® 5000 1.7	17'-11"	15'-6"	14'-1"	12'-1"	17'-11"	15'-6"	14'-1"	12'-7"
	BCI® 6000 1.8	20'-4"	17'-7"	15'-10"	12'-8"	20'-4"	17'-7"	15'-10"	12'-8"
	BCI® 6500 1.8	21'-5"	18'-6"	15'-10"	12'-8"	21'-5"	18'-6"	15'-10"	12'-8"
	BCI® 60 2.0	25'-0"	20'-9"	17'-3"	13'-9"	25'-0"	21'-4"	17'-9"	14'-2"
18"	BCI® 90 2.0	28'-1"	22'-9"	18'-11"	15'-1"	28'-1"	25'-6"	22'-0"	17'-7"
20"	BCI® 90 2.0	30'-8"	23'-7"	19'-8"	15'-8"	30'-8"	27'-0"	22'-6"	18'-0"
20"	BCI® 90 2.0	32'-8"	24'-5"	20'-4"	16'-3"	33'-2"	27'-7"	23'-0"	18'-4"

**Web Stiffeners Required at All Bearing Locations for Table Below**  
Spans without web stiffeners and/or shorter bearings are possible, analyze such conditions with BC CALC® sizing software.

## NOTES FOR BOTH TABLES

- Loading based upon Table 1607.1 of 2009 International Building Code
- Spans limited by allowable moment and reaction values, total load deflection of L/240. Live load deflection limited to L/600 with 50 psf and L/360 with listed uniform live load.
- Table values assume that 23/32" min. plywood/OSB rated sheathing is glued and nailed to joists.
- Table values represent the most restrictive of simple or multiple span applications.
- Table values are the maximum allowable clear distance between supports.
- Table values assume web stiffeners at each bearing location, minimum 2¼" end bearing.
- This table was designed to apply to a broad range of applications. It may be possible to exceed the limitations of this table by analyzing a specific application with the BC CALC® sizing software.
- School and essential service projects in California (DSA) require additional design provisions and thus the above span length limits may not apply. Contact Boise Cascade EWP Engineering for further information.

## Retail - 1st Floor / Schools - 1st Floor Corridors

[Worst Case 100 PSF or 1000 LB Concentrated Live Load] + 25 PSF Dead Load									
Joist Depth	Joist Series	3½" Interior Bearing				5¼" Interior Bearing			
		12" o.c.	16" o.c.	19.2" o.c.	24" o.c.	12" o.c.	16" o.c.	19.2" o.c.	24" o.c.
9½"	BCI® 5000 1.7	12'-5"	10'-9"	9'-3"	7'-5"	12'-5"	10'-9"	9'-10"	8'-8"
	BCI® 6000 1.8	14'-1"	12'-2"	10'-6"	8'-4"	14'-1"	12'-2"	10'-11"	8'-8"
	BCI® 6500 1.8	14'-9"	12'-7"	10'-6"	8'-4"	14'-9"	12'-10"	10'-11"	8'-8"
11⅞"	BCI® 5000 1.7	14'-1"	12'-2"	11'-1"	9'-0"	14'-1"	12'-2"	11'-1"	9'-6"
	BCI® 6000 1.8	16'-0"	13'-7"	11'-3"	9'-0"	16'-0"	13'-10"	11'-11"	9'-6"
	BCI® 6500 1.8	16'-10"	13'-7"	11'-3"	9'-0"	16'-10"	14'-3"	11'-11"	9'-6"
	BCI® 60 2.0	18'-1"	13'-7"	11'-3"	9'-0"	18'-8"	15'-6"	12'-11"	10'-3"
	BCI® 90 2.0	21'-0"	17'-8"	14'-8"	11'-9"	21'-0"	19'-1"	17'-1"	13'-8"
14"	BCI® 5000 1.7	15'-4"	13'-3"	12'-1"	9'-8"	15'-4"	13'-3"	12'-1"	10'-1"
	BCI® 6000 1.8	17'-5"	15'-0"	12'-6"	9'-11"	17'-5"	15'-1"	12'-8"	10'-1"
	BCI® 6500 1.8	18'-4"	15'-0"	12'-6"	9'-11"	18'-4"	15'-3"	12'-8"	10'-1"
	BCI® 60 2.0	21'-2"	16'-5"	13'-8"	10'-11"	21'-2"	17'-5"	14'-6"	11'-7"
	BCI® 90 2.0	23'-9"	18'-4"	15'-3"	12'-2"	23'-9"	21'-3"	17'-8"	14'-1"
16"	BCI® 5000 1.7	16'-5"	14'-2"	12'-8"	10'-1"	16'-5"	14'-2"	12'-11"	10'-7"
	BCI® 6000 1.8	18'-8"	15'-11"	13'-3"	10'-7"	18'-8"	15'-11"	13'-3"	10'-7"
	BCI® 6500 1.8	19'-7"	15'-11"	13'-3"	10'-7"	19'-7"	15'-11"	13'-3"	10'-7"
	BCI® 60 2.0	23'-3"	17'-5"	14'-6"	11'-7"	23'-3"	17'-11"	14'-11"	11'-11"
	BCI® 90 2.0	25'-6"	19'-1"	15'-11"	12'-8"	26'-4"	22'-2"	18'-6"	14'-9"
18"	BCI® 90 2.0	26'-5"	19'-10"	16'-6"	13'-2"	28'-9"	22'-8"	18'-11"	15'-1"
20"	BCI® 90 2.0	27'-5"	20'-6"	17'-1"	13'-8"	30'-11"	23'-2"	19'-3"	15'-5"



Office: Upper Floor Corridors

**Web Stiffeners Required at All Bearing Locations for Table Below**

Spans without web stiffeners and/or shorter bearings are possible, analyze such conditions with BC CALC® sizing software.

[Worst Case 80 PSF or 2000 LB Concentrated Live Load] + 25 PSF Dead Load									
Joist Depth	Joist Series	3½" Interior Bearing				5¼" Interior Bearing			
		12" o.c.	16" o.c.	19.2" o.c.	24" o.c.	12" o.c.	16" o.c.	19.2" o.c.	24" o.c.
9½"	BCI® 5000 1.7	11'-3"	8'-11"	6'-8"	3'-9"	11'-3"	8'-11"	6'-8"	3'-9"
	BCI® 6000 1.8	13'-9"	10'-11"	9'-5"	5'-7"	13'-9"	10'-11"	9'-5"	5'-7"
	BCI® 6500 1.8	14'-11"	11'-10"	10'-3"	5'-7"	14'-11"	11'-10"	10'-3"	5'-7"
11⅞"	BCI® 5000 1.7	13'-8"	10'-11"	9'-5"	6'-3"	13'-8"	10'-11"	9'-5"	6'-3"
	BCI® 6000 1.8	16'-9"	13'-4"	11'-6"	6'-3"	16'-9"	13'-4"	11'-6"	6'-3"
	BCI® 6500 1.8	18'-2"	14'-6"	12'-6"	6'-3"	18'-2"	14'-6"	12'-6"	6'-3"
	BCI® 60 2.0	19'-11"	16'-2"	13'-5"	6'-3"	19'-11"	18'-2"	13'-10"	6'-3"
	BCI® 90 2.0	22'-5"	20'-4"	17'-6"	14'-0"	22'-5"	20'-4"	19'-2"	16'-3"
14"	BCI® 5000 1.7	15'-8"	12'-6"	10'-9"	8'-10"	15'-8"	12'-6"	10'-9"	8'-10"
	BCI® 6000 1.8	19'-0"	15'-3"	13'-3"	8'-10"	19'-0"	15'-3"	13'-3"	8'-10"
	BCI® 6500 1.8	20'-0"	16'-7"	14'-4"	8'-10"	20'-0"	16'-7"	14'-4"	8'-10"
	BCI® 60 2.0	22'-7"	19'-7"	16'-4"	8'-10"	22'-7"	20'-6"	17'-3"	8'-10"
	BCI® 90 2.0	25'-5"	21'-11"	18'-2"	14'-6"	25'-5"	23'-1"	21'-1"	16'-10"
16"	BCI® 5000 1.7	17'-5"	13'-10"	12'-0"	10'-0"	17'-5"	13'-10"	12'-0"	10'-0"
	BCI® 6000 1.8	20'-4"	17'-0"	14'-8"	12'-3"	20'-4"	17'-0"	14'-8"	12'-3"
	BCI® 6500 1.8	21'-5"	18'-5"	15'-10"	12'-6"	21'-5"	18'-5"	15'-10"	12'-6"
	BCI® 60 2.0	25'-0"	20'-9"	17'-3"	12'-6"	25'-0"	21'-4"	17'-9"	12'-6"
	BCI® 90 2.0	28'-1"	22'-9"	18'-11"	15'-1"	28'-1"	25'-6"	22'-0"	17'-7"
18"	BCI® 90 2.0	30'-8"	23'-7"	19'-8"	15'-8"	30'-8"	27'-0"	22'-6"	18'-0"
20"	BCI® 90 2.0	32'-8"	24'-5"	20'-4"	16'-3"	33'-2"	27'-7"	23'-0"	18'-4"

**NOTES**

- Loading based upon Table 1607.1 of 2009 International Building Code.
- Spans limited by allowable moment and reaction values, total load deflection of L/240. Live load deflection limited to L/600 with 50 psf and L/360 with 80 psf.
- Table values assume that 23/32" min. plywood/OSB rated sheathing is glued and nailed to joists.
- Table values represent the most restrictive of simple or multiple span applications.
- Table values are the maximum allowable clear distance between supports.
- Table values assume web stiffeners at each bearing location, minimum 2¼" end bearing.
- This table was designed to apply to a broad range of applications. It may be possible to exceed the limitations of this table by analyzing a specific application with the BC CALC® sizing software.
- School and essential service projects in California (DSA) require additional design provisions and thus the above span length limits may not apply. Contact Boise Cascade EWP Engineering for further information.

# 100 PSF Live Load Span Tables

Hotels: Public Rooms & Corridors  
Retail - All Corridors; Medical - 1st Floor Corridors  
Restaurants & Dining Rooms

Assembly Areas & Theatres: Lobbies, Movable Seat Areas

**Web Stiffeners Required at All Bearing Locations for Table Below**

Spans without web stiffeners and/or shorter bearings are possible, analyze such conditions with BC CALC<sup>®</sup> sizing software.

100 PSF Live Load + 25 PSF Dead Load

Joist Depth	Joist Series	3½" Interior Bearing				5¼" Interior Bearing			
		12" o.c.	16" o.c.	19.2" o.c.	24" o.c.	12" o.c.	16" o.c.	19.2" o.c.	24" o.c.
9½"	BCI <sup>®</sup> 5000 1.7	12'-5"	10'-9"	9'-3"	7'-5"	12'-5"	10'-9"	9'-10"	8'-8"
	BCI <sup>®</sup> 6000 1.8	14'-1"	12'-2"	10'-6"	8'-4"	14'-1"	12'-2"	10'-11"	8'-8"
	BCI <sup>®</sup> 6500 1.8	14'-9"	12'-7"	10'-6"	8'-4"	14'-9"	12'-10"	10'-11"	8'-8"
11⅞"	BCI <sup>®</sup> 5000 1.7	14'-1"	12'-2"	11'-1"	9'-0"	14'-1"	12'-2"	11'-1"	9'-6"
	BCI <sup>®</sup> 6000 1.8	16'-0"	13'-7"	11'-3"	9'-0"	16'-0"	13'-10"	11'-11"	9'-6"
	BCI <sup>®</sup> 6500 1.8	16'-10"	13'-7"	11'-3"	9'-0"	16'-10"	14'-3"	11'-11"	9'-6"
	BCI <sup>®</sup> 60 2.0	18'-1"	13'-7"	11'-3"	9'-0"	18'-8"	15'-6"	12'-11"	10'-3"
	BCI <sup>®</sup> 90 2.0	21'-0"	17'-8"	14'-8"	11'-9"	21'-0"	19'-1"	17'-1"	13'-8"
14"	BCI <sup>®</sup> 5000 1.7	15'-4"	13'-3"	12'-1"	9'-8"	15'-4"	13'-3"	12'-1"	10'-1"
	BCI <sup>®</sup> 6000 1.8	17'-5"	15'-0"	12'-6"	9'-11"	17'-5"	15'-1"	12'-8"	10'-1"
	BCI <sup>®</sup> 6500 1.8	18'-4"	15'-0"	12'-6"	9'-11"	18'-4"	15'-3"	12'-8"	10'-1"
	BCI <sup>®</sup> 60 2.0	21'-2"	16'-5"	13'-8"	10'-11"	21'-2"	17'-5"	14'-6"	11'-7"
	BCI <sup>®</sup> 90 2.0	23'-9"	18'-4"	15'-3"	12'-2"	23'-9"	21'-3"	17'-8"	14'-1"
16"	BCI <sup>®</sup> 6000 1.8	16'-5"	14'-2"	12'-8"	10'-1"	16'-5"	14'-2"	12'-11"	10'-7"
	BCI <sup>®</sup> 6000 1.8	18'-8"	15'-11"	13'-3"	10'-7"	18'-8"	15'-11"	13'-3"	10'-7"
	BCI <sup>®</sup> 6500 1.8	19'-7"	15'-11"	13'-3"	10'-7"	19'-7"	15'-11"	13'-3"	10'-7"
	BCI <sup>®</sup> 60 2.0	23'-3"	17'-5"	14'-6"	11'-7"	23'-3"	17'-11"	14'-11"	11'-11"
	BCI <sup>®</sup> 90 2.0	25'-6"	19'-1"	15'-11"	12'-8"	26'-4"	22'-2"	18'-6"	14'-9"
18"	BCI <sup>®</sup> 90 2.0	26'-5"	19'-10"	16'-6"	13'-2"	28'-9"	22'-8"	18'-11"	15'-1"
20"	BCI <sup>®</sup> 90 2.0	27'-5"	20'-6"	17'-1"	13'-8"	30'-11"	23'-2"	19'-3"	15'-5"

## NOTES

- Loading based upon Table 1607.1 of 2009 International Building Code.
- Spans limited by allowable moment and reaction values, total load deflection of L/240. Live load deflection limited to L/600 with 50 psf and L/360 with 100 psf.
- Table values assume that 23/32" min. plywood/OSB rated sheathing is glued and nailed to joists.
- Table values represent the most restrictive of simple or multiple span applications.
- Table values are the maximum allowable clear distance between supports.
- Table values assume web stiffeners at each bearing location, minimum 2¼" end bearing.
- This table was designed to apply to a broad range of applications. It may be possible to exceed the limitations of this table by analyzing a specific application with the BC CALC<sup>®</sup> sizing software.
- School and essential service projects in California (DSA) require additional design provisions and thus the above span length limits may not apply. Contact Boise Cascade EWP Engineering for further information.

Office: Lobbies & 1st Floor Corridors

**Web Stiffeners Required at All Bearing Locations for Table Below**

Spans without web stiffeners and/or shorter bearings are possible, analyze such conditions with BC CALC<sup>®</sup> sizing software.

[Worst Case 100 PSF or 2000 LB Concentrated Live Load] + 25 PSF Dead Load									
Joist Depth	Joist Series	3½" Interior Bearing				5¼" Interior Bearing			
		12" o.c.	16" o.c.	19.2" o.c.	24" o.c.	12" o.c.	16" o.c.	19.2" o.c.	24" o.c.
9½"	BCI <sup>®</sup> 5000 1.7	11'-3"	8'-11"	6'-8"	3'-9"	11'-3"	8'-11"	6'-8"	3'-9"
	BCI <sup>®</sup> 6000 1.8	13'-9"	10'-11"	9'-5"	5'-7"	13'-9"	10'-11"	9'-5"	5'-7"
	BCI <sup>®</sup> 6500 1.8	14'-9"	11'-10"	10'-3"	5'-7"	14'-9"	11'-10"	10'-3"	5'-7"
11⅞"	BCI <sup>®</sup> 5000 1.7	13'-8"	10'-11"	9'-5"	6'-3"	13'-8"	10'-11"	9'-5"	6'-3"
	BCI <sup>®</sup> 6000 1.8	16'-0"	13'-4"	11'-3"	6'-3"	16'-0"	13'-4"	11'-6"	6'-3"
	BCI <sup>®</sup> 6500 1.8	16'-10"	13'-7"	11'-3"	6'-3"	16'-10"	14'-3"	11'-11"	6'-3"
	BCI <sup>®</sup> 60 2.0	18'-1"	13'-7"	11'-3"	6'-3"	18'-8"	15'-6"	12'-11"	6'-3"
	BCI <sup>®</sup> 90 2.0	21'-0"	17'-8"	14'-8"	11'-9"	21'-0"	19'-1"	17'-1"	13'-8"
14"	BCI <sup>®</sup> 5000 1.7	15'-4"	12'-6"	10'-9"	8'-10"	15'-4"	12'-6"	10'-9"	8'-10"
	BCI <sup>®</sup> 6000 1.8	17'-5"	15'-0"	12'-6"	8'-10"	17'-5"	15'-1"	12'-8"	8'-10"
	BCI <sup>®</sup> 6500 1.8	18'-4"	15'-0"	12'-6"	8'-10"	18'-4"	15'-3"	12'-8"	8'-10"
	BCI <sup>®</sup> 60 2.0	21'-2"	16'-5"	13'-8"	8'-10"	21'-2"	17'-5"	14'-6"	8'-10"
	BCI <sup>®</sup> 90 2.0	23'-9"	18'-4"	15'-3"	12'-2"	23'-9"	21'-3"	17'-8"	14'-1"
16"	BCI <sup>®</sup> 5000 1.7	16'-5"	13'-10"	12'-0"	10'-0"	16'-5"	13'-10"	12'-0"	10'-0"
	BCI <sup>®</sup> 6000 1.8	18'-8"	15'-11"	13'-3"	10'-7"	18'-8"	15'-11"	13'-3"	10'-7"
	BCI <sup>®</sup> 6500 1.8	19'-7"	15'-11"	13'-3"	10'-7"	19'-7"	15'-11"	13'-3"	10'-7"
	BCI <sup>®</sup> 60 2.0	23'-3"	17'-5"	14'-6"	11'-7"	23'-3"	17'-11"	14'-11"	11'-11"
	BCI <sup>®</sup> 90 2.0	25'-6"	19'-1"	15'-11"	12'-8"	26'-4"	22'-2"	18'-6"	14'-9"
18"	BCI <sup>®</sup> 90 2.0	26'-5"	19'-10"	16'-6"	13'-2"	28'-9"	22'-8"	18'-11"	15'-1"
20"	BCI <sup>®</sup> 90 2.0	27'-5"	20'-6"	17'-1"	13'-8"	30'-11"	23'-2"	19'-3"	15'-5"

**NOTES**

- Loading based upon Table 1607.1 of 2009 International Building Code.
- Spans limited by allowable moment and reaction values, total load deflection of L/240. Live load deflection limited to L/600 with 50 psf and L/360 with 100 psf.
- Table values assume that 23/32" min. plywood/OSB rated sheathing is glued and nailed to joists.
- Table values represent the most restrictive of simple or multiple span applications.
- Table values are the maximum allowable clear distance between supports.
- Table values assume web stiffeners at each bearing location, minimum 2¼" end bearing.
- This table was designed to apply to a broad range of applications. It may be possible to exceed the limitations of this table by analyzing a specific application with the BC CALC<sup>®</sup> sizing software.
- School and essential service projects in California (DSA) require additional design provisions and thus the above span length limits may not apply. Contact Boise Cascade EWP Engineering for further information.

# 125 PSF Live Load (Light Storage) Span Tables

## Web Stiffeners Required at All Bearing Locations for Table Below

Spans without web stiffeners and/or shorter bearings are possible, analyze such conditions with BC CALC<sup>®</sup> sizing software.

125 PSF Live Load + 25 PSF Dead Load

Joist Depth	Joist Series	3½" Interior Bearing				5¼" Interior Bearing			
		12" o.c.	16" o.c.	19.2" o.c.	24" o.c.?	12" o.c.	16" o.c.	19.2" o.c.	24" o.c.?
9½"	BCI <sup>®</sup> 5000 1.7	11'-4"	9'-3"	7'-9"	6'-2"	11'-4"	9'-10"	8'-11"	7'-3"
	BCI <sup>®</sup> 6000 1.8	12'-10"	10'-6"	8'-9"	6'-11"	12'-10"	10'-11"	9'-0"	7'-3"
	BCI <sup>®</sup> 6500 1.8	13'-7"	10'-6"	8'-9"	6'-11"	13'-7"	10'-11"	9'-0"	7'-3"
11⅞"	BCI <sup>®</sup> 5000 1.7	12'-10"	11'-1"	9'-5"	7'-6"	12'-10"	11'-1"	9'-11"	7'-11"
	BCI <sup>®</sup> 6000 1.8	14'-7"	11'-3"	9'-5"	7'-6"	14'-7"	11'-11"	9'-11"	7'-11"
	BCI <sup>®</sup> 6500 1.8	15'-1"	11'-3"	9'-5"	7'-6"	15'-4"	11'-11"	9'-11"	7'-11"
	BCI <sup>®</sup> 60 2.0	15'-1"	11'-3"	9'-5"	7'-6"	17'-2"	12'-11"	10'-9"	8'-6"
	BCI <sup>®</sup> 90 2.0	19'-4"	14'-8"	12'-3"	9'-9"	19'-4"	17'-1"	14'-3"	11'-4"
14"	BCI <sup>®</sup> 5000 1.7	14'-0"	12'-1"	10'-0"	8'-0"	14'-0"	12'-1"	10'-6"	8'-5"
	BCI <sup>®</sup> 6000 1.8	15'-11"	12'-6"	10'-5"	8'-3"	15'-11"	12'-8"	10'-6"	8'-5"
	BCI <sup>®</sup> 6500 1.8	16'-8"	12'-6"	10'-5"	8'-3"	16'-9"	12'-8"	10'-6"	8'-5"
	BCI <sup>®</sup> 60 2.0	18'-3"	13'-8"	11'-5"	9'-1"	19'-4"	14'-6"	12'-0"	9'-7"
	BCI <sup>®</sup> 90 2.0	20'-5"	15'-3"	12'-9"	10'-2"	21'-11"	17'-8"	14'-9"	11'-9"
16"	BCI <sup>®</sup> 5000 1.7	14'-11"	12'-8"	10'-6"	8'-5"	14'-11"	12'-11"	11'-0"	8'-10"
	BCI <sup>®</sup> 6000 1.8	17'-0"	13'-3"	11'-0"	8'-10"	17'-0"	13'-3"	11'-0"	8'-10"
	BCI <sup>®</sup> 6500 1.8	17'-9"	13'-3"	11'-0"	8'-10"	17'-9"	13'-3"	11'-0"	8'-10"
	BCI <sup>®</sup> 60 2.0	19'-4"	14'-6"	12'-0"	9'-7"	19'-11"	14'-11"	12'-5"	9'-11"
	BCI <sup>®</sup> 90 2.0	21'-2"	15'-11"	13'-3"	10'-6"	24'-3"	18'-6"	15'-5"	12'-3"
18"	BCI <sup>®</sup> 90 2.0	22'-0"	16'-6"	13'-9"	10'-11"	25'-2"	18'-11"	15'-9"	12'-6"
20"	BCI <sup>®</sup> 90 2.0	22'-10"	17'-1"	14'-3"	11'-4"	25'-9"	19'-3"	16'-1"	12'-10"

### NOTES

- Loading based upon Table 1607.1 of 2009 International Building Code.
- Spans limited by allowable moment and reaction values, total load deflection of L/240. Live load deflection limited to L/600 with 50 psf and L/360 with 125 psf.
- Table values assume that 23/32" min. plywood/OSB rated sheathing is glued and nailed to joists.
- Table values represent the most restrictive of simple or multiple span applications.
- Table values are the maximum allowable clear distance between supports.
- Table values assume web stiffeners at each bearing location, minimum 2¼" end bearing.
- This table was designed to apply to a broad range of applications. It may be possible to exceed the limitations of this table by analyzing a specific application with the BC CALC<sup>®</sup> sizing software.
- School and essential service projects in California (DSA) require additional design provisions and thus the above span length limits may not apply. Contact Boise Cascade EWP Engineering for further information.

## Web Stiffeners Required at All Bearing Locations for Table Below

Spans without web stiffeners and/or shorter bearings are possible, analyze such conditions with BC CALC<sup>®</sup> sizing software.

250 PSF Live Load + 25 PSF Dead Load

Joist Depth	Joist Series	3½" Interior Bearing			5¼" Interior Bearing		
		12" o.c.	16" o.c.	19.2" o.c.	12" o.c.	16" o.c.	19.2" o.c.
9½"	BCI <sup>®</sup> 5000 1.7	6'-9"	5'-0"	4'-2"	7'-11"	5'-11"	4'-11"
	BCI <sup>®</sup> 6000 1.8	7'-7"	5'-8"	4'-8"	7'-11"	5'-11"	4'-11"
	BCI <sup>®</sup> 6500 1.8	7'-7"	5'-8"	4'-8"	7'-11"	5'-11"	4'-11"
11⅝"	BCI <sup>®</sup> 5000 1.7	8'-2"	6'-1"	5'-1"	8'-7"	6'-5"	5'-4"
	BCI <sup>®</sup> 6000 1.8	8'-2"	6'-1"	5'-1"	8'-7"	6'-5"	5'-4"
	BCI <sup>®</sup> 6500 1.8	8'-2"	6'-1"	5'-1"	8'-7"	6'-5"	5'-4"
	BCI <sup>®</sup> 60 2.0	8'-2"	6'-1"	5'-1"	9'-4"	7'-0"	5'-9"
	BCI <sup>®</sup> 90 2.0	10'-8"	7'-11"	6'-7"	12'-5"	9'-3"	7'-8"
14"	BCI <sup>®</sup> 5000 1.7	8'-9"	6'-6"	5'-5"	9'-2"	6'-10"	5'-8"
	BCI <sup>®</sup> 6000 1.8	9'-0"	6'-9"	5'-7"	9'-2"	6'-10"	5'-8"
	BCI <sup>®</sup> 6500 1.8	9'-0"	6'-9"	5'-7"	9'-2"	6'-10"	5'-8"
	BCI <sup>®</sup> 60 2.0	9'-11"	7'-5"	6'-2"	10'-6"	7'-10"	6'-6"
	BCI <sup>®</sup> 90 2.0	11'-1"	8'-3"	6'-11"	12'-10"	9'-7"	8'-0"
16"	BCI <sup>®</sup> 5000 1.7	9'-2"	6'-10"	5'-8"	9'-7"	7'-2"	6'-0"
	BCI <sup>®</sup> 6000 1.8	9'-7"	7'-2"	6'-0"	9'-7"	7'-2"	6'-0"
	BCI <sup>®</sup> 6500 1.8	9'-7"	7'-2"	6'-0"	9'-7"	7'-2"	6'-0"
	BCI <sup>®</sup> 60 2.0	10'-6"	7'-10"	6'-6"	10'-9"	8'-1"	6'-8"
	BCI <sup>®</sup> 90 2.0	11'-6"	8'-7"	7'-2"	13'-5"	10'-0"	8'-4"
18"	BCI <sup>®</sup> 90 2.0	11'-11"	8'-11"	7'-5"	13'-8"	10'-3"	8'-6"
20"	BCI <sup>®</sup> 90 2.0	12'-5"	9'-3"	7'-8"	14'-0"	10'-5"	8'-8"

### NOTES

- Loading based upon Table 1607.1 of 2009 International Building Code.
- Spans limited by allowable moment and reaction values, total load deflection of L/240. Live load deflection limited to L/600 with 50 psf and L/360 with 250 psf.
- Table values assume that 23/32" min. plywood/OSB rated sheathing is glued and nailed to joists.
- Table values represent the most restrictive of simple or multiple span applications.
- Table values are the maximum allowable clear distance between supports.
- Table values assume web stiffeners at each bearing location, minimum 2¼" end bearing.
- This table was designed to apply to a broad range of applications. It may be possible to exceed the limitations of this table by analyzing a specific application with the BC CALC<sup>®</sup> sizing software.
- School and essential service projects in California (DSA) require additional design provisions and thus the above span length limits may not apply. Contact Boise Cascade EWP Engineering for further information.

## BCI® Joists

## NOTE

The illustration below is showing several suggested applications for the Boise Cascade EWP products. It is not intended to show an actual house under construction.

**NO MIDSPAN BRIDGING IS REQUIRED FOR BCI® JOISTS**

**FOR INSTALLATION STABILITY,** Temporary strut lines (1x4 min.) 8' on center max. Fasten at each joist with 2-8d nails minimum.

Dimension lumber is not suitable for use as a rim board in BCI® floor systems.

BCI® rim joist.  
See page 15.

BC Rimboard  
See pages 15 and 34.

For load bearing cantilever details, see page 19.

See also Intermediate Bearing details, page 15

When installing Boise Cascade EWP products with treated wood, use only connectors/fasteners that are approved for use with the corresponding wood treatment.

VERSA-LAM® header or a BCI® Joist header.

1½" knockout holes at approximately 12" o.c. are pre-punched.

See page 17 for allowable hole sizes and location.

VERSA-LAM® LVL beam.

Endwall blocking as required per governing building code.

BCI® Joist Blocking is required when BCI® Joists are cantilevered.

BCI® Joists, VERSA-LAM® and ALLJOIST® must be stored, installed and used in accordance with the Boise Cascade EWP Installation Guide, building codes, and to the extent not inconsistent with the Boise Cascade EWP Installation Guide, usual and customary building practices and standards. VERSA-LAM®, ALLJOIST®, and BCI® Joists must be wrapped, covered, and stored off of the ground on stickers at all times prior to installation. VERSA-LAM®, ALLJOIST® and BCI®

Joists are intended only for applications that assure no exposure to weather or the elements and an environment that is free from moisture from any source, or any pest, organism or substance which degrades or damages wood or glue bonds. Failure to correctly store, use or install VERSA-LAM®, ALLJOIST®, and BCI® Joist in accordance with the Boise Cascade EWP Installation Guide will void the limited warranty.

**SAFETY WARNING**

**DO NOT ALLOW WORKERS ON BCI® JOISTS UNTIL ALL HANGERS, BCI® RIM JOISTS, RIM BOARDS, BCI® BLOCKING PANELS, X-BRACING AND TEMPORARY 1x4 STRUT LINES ARE INSTALLED AS SPECIFIED BELOW. SERIOUS ACCIDENTS CAN RESULT FROM INSUFFICIENT ATTENTION TO PROPER BRACING DURING CONSTRUCTION. ACCIDENTS CAN BE AVOIDED UNDER NORMAL CONDITIONS BY FOLLOWING THESE GUIDELINES:**

- Build a braced end wall at the end of the bay, or permanently install the first eight feet of BCI® Joists and the first course of sheathing. As an alternate, temporary sheathing may be nailed to the first four feet of BCI® Joists at the end of the bay.
- All hangers, BCI® rim joists, rim boards, BCI® blocking panels, and x-bracing must be completely installed and properly nailed as each BCI® Joist is set.
- Install temporary 1x4 strut lines at no more than eight feet on center as additional BCI® Joists are set. Nail the strut lines to the sheathed area, or braced end wall, and to each BCI® Joist with two 8d nails.
- The ends of cantilevers must be temporarily secured by strut lines on both the top and bottom flanges.
- Straighten the BCI® Joists to within ½ inch of true alignment before attaching strut lines and sheathing.
- Remove the temporary strut lines only as required to install the permanent sheathing.
- Failure to install temporary bracing may result in sideways buckling or roll-over under light construction loads.
- Do not stack construction materials (sheathing, drywall, etc) in the middle of BCI® Joist spans, contact Boise Cascade EWP Engineering for proper storage and shoring information.



Additional floor framing details available with BC FRAMER® software

## END BEARING DETAILS

<p><b>F07</b></p> <p>Nail Boise Cascade Rimboard to BCI® Joists with 8d nail into each flange.</p> <p>Dimension lumber is not suitable for use as rim board with BCI® Joists.</p>	<p><b>F07A</b></p> <p>Dimension lumber is not suitable for use as rim board with BCI® Joists.</p>	<p><b>F02</b></p> <p>BCI® rim joist.</p>
<p><b>F01</b></p> <p>BCI® Joist blocking.</p>	<p><b>F27A</b></p> <p>Top Flange or Face Mount Joist Hanger</p> <p>VERSA-LAM®</p>	<p><b>F52</b></p> <p>One 8d nail each side at bearing</p> <p>1½" minimum bearing length</p> <p>To limit splitting flange, start nails at least 1½" from end. Nails may need to be driven at an angle to limit splitting of bearing plate.</p>
<p><b>F08</b></p> <p>Solid block all posts from above to bearing below.</p>	<p><b>F03</b></p> <p>BCI® rim joist.</p> <p>Note: BCI® floor joist must be designed to carry wall above when not stacked over wall below.</p>	<p><b>F52</b></p> <p>Boise Cascade Rimboard</p> <p>Braced wall panel or shear wall</p> <p>2x4 block, attach with (2) 8d nails or #8 screws per web. Use construction adhesive to limit floor squeaks.</p> <p>Flat 2x4 blocking with clips may substitute for BCI® blocking.</p> <p>Note: BCI® joist must be designed to support vertical loads from wall above.</p>

### LATERAL SUPPORT

- BCI® Joists shall be laterally supported at the ends with hangers, rimboard, BCI® rim joist or blocking panels. BCI® blocking panels or rimboard are required at cantilever supports.
- Blocking may be required at intermediate bearings for floor diaphragm per IRC in high seismic areas, consult local building official.

### MINIMUM BEARING LENGTH FOR BCI® JOISTS

- Minimum end bearing: 1½" for BCI® 5000, 6000 & 6500; 1¾" for BCI® 60 & 90. 3½" is required at cantilever and intermediate supports.
- Longer bearing lengths allow higher reaction values. Refer to the building code evaluation report or the BC CALC® software.

### NAILING REQUIREMENTS

- BCI® rim joist, rim board or closure panel to BCI® joist:
  - Rims or closure panel 1¾ inches thick and less: 2-8d nails, one each in the top and bottom flange.
  - BCI® 5000 rim joist: 2-10d box nails, one each in the top and bottom flange.
  - BCI® 6000, 60 rim joist: 2-16d box nails, one each in the top and bottom flange.
  - BCI® 6500, 90 rim joist: Toe-nail top flange to rim joist with 2-10d box nails, one each side of flange.

- BCI® rim joist, rim board or BCI® blocking panel to support:
  - Min. 8d nails @ 6" o.c. per IRC.
  - Connection per design professional of record's specification for shear transfer.
- BCI® joist to support:
  - 2-8d nails, one on each side of the web, placed 1½ inches minimum from the end of the BCI® Joist to limit splitting.
- Sheathing to BCI® joist:
  - Prescriptive residential floor sheathing nailing requires 8d common nails @ 6" o.c. on edges and @ 12" o.c. in the field (IRC Table R602.3(1)).
  - See closest allowable nail spacing limits on page 24 for floor diaphragm nailing specified at closer spacing than IRC.
  - Maximum nail spacing for minimum lateral stability: 18" for BCI® 5000, 24" for larger BCI® joist series.
  - 14 gauge staples may be substituted for 8d nails if the staples penetrate at least 1 inch into the joist.
  - Wood screws may be acceptable, contact local building official and/or Boise Cascade EWP Engineering for further information.

Additional floor framing details available with BC FRAMER® software

## INTERMEDIATE BEARING DETAILS

**F06**

For load bearing wall above (stacked over wall below).

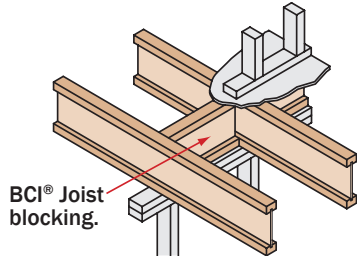

**F09**

Blocking may be required at intermediate bearings for floor diaphragm per IRC in high seismic areas, consult local building official.

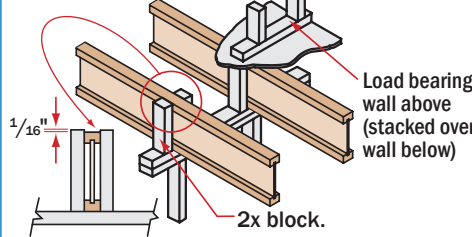

**F28**

Floor Joist Blocking per IRC 502.7 Required in seismic design categories D<sub>0</sub> and higher for floor diaphragm (required for all joist types).

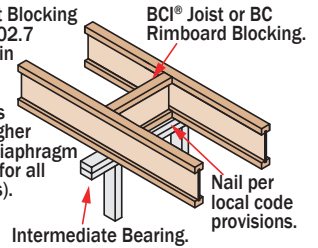

Cross bracing OK as blocking only if support below is not a braced wall panel or shear wall and no wall exists above.

**F10**

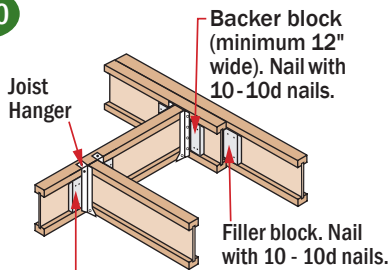

Backer block required where top flange joist hanger load exceeds 250 lbs. Install tight to top flange.

**F58**

### Double BCI Joist Connection

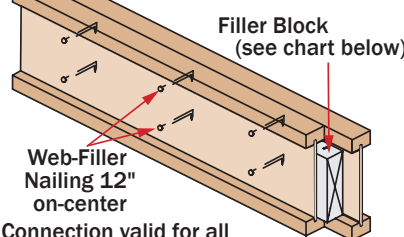

Connection valid for all applications. Contact Boise Cascade EWP Engineering for specific conditions.

**F14**

### BCI Joist Slope Cut Reinforcement

Detail below restores original allowable shear/reaction value to cut end of BCI joist. BCI Joist shall not be used as a collar or rafter tension tie.

2 x 6 min. rafter. Rafter shall be supported by ridge beam or other upper bearing support

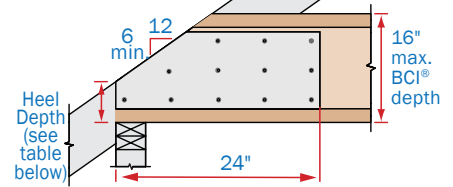

2x blocking required at bearing (not shown for clarity). <sup>23</sup>/<sub>32</sub> min. plywood/OSB rated sheathing as reinforcement. Install reinforcement with face grain horizontal. Install on both sides of the joist, tight to bottom flange. Leave minimum 1/4" gap between reinforcement and bottom of top flange. Apply construction adhesive to contact surfaces and fasten with 3 rows of min. 10d box nails at 6" o.c. Alternate nailing from each side and clinch.

End Wall Bearing	Minimum Heel Depth					
	Roof Pitch					
	6/12	7/12	8/12	9/12	10/12	12/12
2 x 4	4 <sup>3</sup> / <sub>8</sub> "	4 <sup>5</sup> / <sub>16</sub> "	4 <sup>1</sup> / <sub>4</sub> "	4 <sup>1</sup> / <sub>4</sub> "	4 <sup>1</sup> / <sub>4</sub> "	4 <sup>1</sup> / <sub>4</sub> "
2 x 6	3 <sup>3</sup> / <sub>8</sub> "	3 <sup>3</sup> / <sub>16</sub> "	2 <sup>5</sup> / <sub>16</sub> "	2 <sup>3</sup> / <sub>4</sub> "	2 <sup>3</sup> / <sub>16</sub> "	2 <sup>1</sup> / <sub>4</sub> "

**F05**

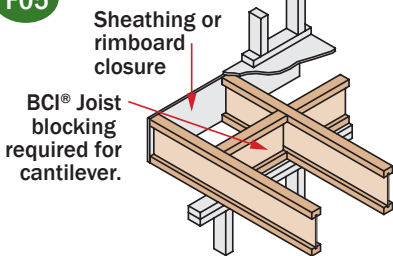

For load bearing cantilever, see page 19. Uplift on backspan shall be considered in all cantilever designs.

Connector strap nailing schedule shall adhere to BCI closest nailing spacing provisions

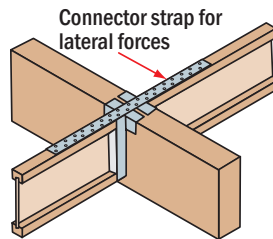

See connector manufacturer's code evaluation reports and literature for allowable loading. Axial force in top flange shall be considered in BCI joist design.

## BACKER AND FILLER BLOCK DIMENSIONS

Series	Backer Block Thickness	Filler Block Thickness
5000 1.7	3/4" or 7/8" wood panels	Two 3/4" wood panels or 2x_
6000 1.8	1 1/8" or two 1/2" wood panels	2x_ + 7/16" or 1/2" wood panel
6500 1.8	1 1/8" or two 5/8" wood panels	2x_ + 5/8" or 3/4" wood panel
60 2.0	1 1/8" or two 1/2" wood panels	2x_ + 7/16" or 1/2" wood panel
90 2.0	2x_ lumber	Double 2x_ lumber

- Cut backer and filler blocks to a maximum depth equal to the web depth minus 1/4" to avoid a forced fit.

## WEB STIFFENER REQUIREMENTS

- See *Web Stiffener Requirements* on page 18.

## PROTECT BCI JOISTS FROM THE WEATHER

- BCI Joists are intended only for applications that provide permanent protection from the weather. Bundles of BCI Joists should be covered and stored off of the ground on stickers.

## BCI RIM JOISTS AND BCI BLOCKING

Depth [in]	Series	Vertical Load Capacity	
		No W.S. <sup>(1)</sup>	W.S. <sup>(2)</sup>
9 1/2"	5000 1.7, 6000 1.8, 6500 1.8	2300	N/A
11 1/8"	5000 1.7, 6000 1.8, 6500 1.8	2150	N/A
	60 2.0, 90 2.0	2500	N/A
14"	5000 1.7, 6000 1.8, 6500 1.8	2000	N/A
	60 2.0, 90 2.0	2400	N/A
16"	6000 1.8, 6500 1.8	1900	2500
	60 2.0, 90 2.0	2300	2700
18"	60 2.0, 90 2.0	N/A	2700
20"	90 2.0	N/A	2700

(1) No web stiffeners required

(2) Web stiffeners required at each end of blocking, values not applicable for rim joists

N/A: Not applicable



<h3 style="text-align: center;">Floor Bracing for Endwall</h3> <p>Block spacing per governing code and diaphragm nailing per engineer of record. Intent of blocking is to resist external lateral forces acting perpendicular to wall.</p> <p>Boise Cascade Rimboard</p> <p>BCI® Joist</p> <p>BCI® Blocking</p> <p>Sill Plate</p> <p>BCI® Joist Blocking</p> <p>(2) 8d nails or #8 wood screws per web</p> <p>2x4 lumber</p> <p>Apply construction adhesive to contact surfaces to limit floor squeaks.</p>	<h3 style="text-align: center;">BCI® Joist Fire Cut</h3> <p>Masonry or concrete wall</p> <p>DO NOT bevel cut beyond inside face of wall</p> <p>Bond beam</p> <p>Bearing plate shall be properly fastened to bond beam</p> <ol style="list-style-type: none"> <li>1) Joists shall be restrained from rotation at end bearing by installing blocking panels or cross-bridging between joists (not shown for clarity).</li> <li>2) Joists shall not be in direct contact with masonry or concrete. A minimum of 1/2" of air space or an adequate moisture barrier shall be provided between joists and wall pocket.</li> <li>3) Joists are to be installed in dry-use conditions only.</li> </ol>
<h3 style="text-align: center;">Blocked Diaphragm Nailing Detail</h3> <p>Simpson Strong-Tie Z2 blocking clip</p> <p>Flat 2x4's at panel edges for diaphragm nailing</p> <p>Apply construction adhesive to contact surfaces to limit floor squeaks.</p>	<h3 style="text-align: center;">Hanger Connections to BCI® Headers</h3> <ul style="list-style-type: none"> <li>• Backer blocks shall be at least 12" long per hanger.</li> <li>• Nails shall be clinched when possible.</li> <li>• Verify capacity and fastening requirements of hangers and connectors.</li> </ul> <p>Backer Block</p> <p>1/4" to 2" gap</p> <p>"Top Mount"</p> <p>Backer block shall be tight to bottom of top flange with 1/4" to 2" gap at top of bottom flange.</p> <p>"Face Mount"</p> <p>Backer block shall be tight to bottom of top flange with 1/4" to 2" gap at top of bottom flange.</p>
<h3 style="text-align: center;">Connection on Steel Beam</h3> <p><b>F15D</b></p> <p>Sill plate to be properly anchored to steel beam</p> <p>Steel beam</p>	<h3 style="text-align: center;">Connection on Hanger with Steel Beam</h3> <p><b>F15E</b></p> <p>Sill plate to be properly anchored to steel beam</p> <p>Steel beam</p> <p>Backer block optional</p>

# BCI® Joist Hole Location & Sizing

BCI® Joists are manufactured with 1½" round perforated knockouts in the web at approximately 12" on center

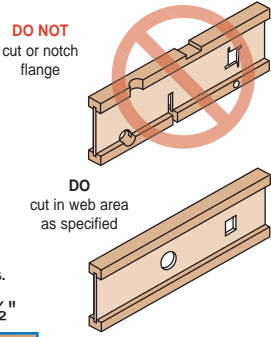
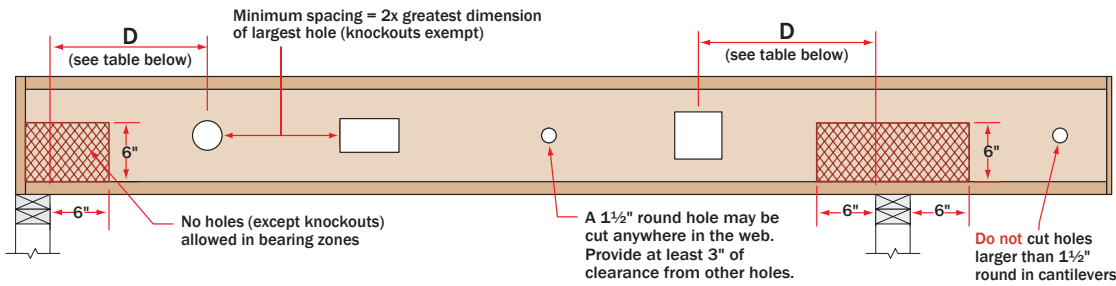

Minimum distance from support, listed in table below, is required for all holes greater than 1½"

MINIMUM DISTANCE (D) FROM ANY SUPPORT TO THE CENTERLINE OF THE HOLE																
Round Hole Diameter [in]		2	3	4	5	6	7	8	8 7/8	10	11	12	13	14	15	
Rectangular Hole Side [in]		-	-	-	3	5	7	-	-	-	-	-	-	-	-	
Any 9½" Joist	Span [ft]	8	1'-0"	1'-1"	1'-8"	2'-4"	2'-11"	3'-7"								
		12	1'-0"	1'-7"	2'-7"	3'-6"	4'-5"	5'-4"								
		16	1'-0"	2'-2"	3'-5"	4'-8"	5'-11"	7'-2"								
Round Hole Diameter [in]		2	3	4	5	6	7	8	8 7/8	10	11	12	13	14	15	
Rectangular Hole Side [in]		-	-	-	2	3	5	7	8	-	-	-	-	-	-	
Any 11 7/8" Joist	Span [ft]	8	1'-0"	1'-1"	1'-6"	2'-0"	2'-5"	2'-11"	3'-5"	3'-10"						
		12	1'-0"	1'-7"	2'-3"	3'-0"	3'-8"	4'-5"	5'-1"	5'-9"						
		16	1'-2"	2'-1"	3'-0"	4'-0"	4'-11"	5'-10"	6'-10"	7'-8"						
		20	1'-5"	2'-7"	3'-10"	5'-0"	6'-2"	7'-4"	8'-6"	9'-7"						
Round Hole Diameter [in]		2	3	4	5	6	7	8	8 7/8	10	11	12	13	14	15	
Rectangular Hole Side [in]		-	-	-	-	2	3	5	6	8	9	-	-	-	-	
Any 14" Joist	Span [ft]	8	1'-0"	1'-1"	1'-2"	1'-2"	1'-6"	1'-11"	2'-4"	2'-9"	3'-3"	3'-8"				
		12	1'-0"	1'-1"	1'-2"	1'-7"	2'-3"	2'-11"	3'-6"	4'-1"	4'-10"	5'-6"				
		16	1'-0"	1'-1"	1'-3"	2'-2"	3'-0"	3'-10"	4'-9"	5'-6"	6'-6"	7'-4"				
		20	1'-0"	1'-1"	1'-7"	2'-8"	3'-9"	4'-10"	5'-11"	6'-10"	8'-1"	9'-2"				
		24	1'-0"	1'-1"	1'-11"	3'-3"	4'-6"	5'-10"	7'-1"	8'-3"	9'-9"	11'-0"				
Round Hole Diameter [in]		2	3	4	5	6	7	8	8 7/8	10	11	12	13	14	15	
Rectangular Hole Side [in]		-	-	-	-	-	2	3	5	6	8	9	10	-	-	
Any 16" Joist	Span [ft]	8	1'-0"	1'-1"	1'-2"	1'-2"	1'-3"	1'-3"	1'-7"	1'-11"	2'-4"	2'-9"	3'-2"	3'-7"		
		12	1'-0"	1'-1"	1'-2"	1'-2"	1'-3"	1'-9"	2'-4"	2'-11"	3'-7"	4'-2"	4'-9"	5'-4"		
		16	1'-0"	1'-1"	1'-2"	1'-2"	1'-7"	2'-5"	3'-2"	3'-10"	4'-9"	5'-7"	6'-4"	7'-2"		
		20	1'-0"	1'-1"	1'-2"	1'-2"	2'-0"	3'-0"	4'-0"	4'-10"	5'-11"	6'-11"	7'-11"	8'-11"		
		24	1'-0"	1'-1"	1'-2"	1'-3"	2'-5"	3'-7"	4'-9"	5'-10"	7'-2"	8'-4"	9'-6"	10'-9"		
Round Hole Diameter [in]		2	3	4	5	6	7	8	8 7/8	10	11	12	13	14	15	
Rectangular Hole Side [in]		-	-	-	-	-	-	2	3	5	6	7	9	10	11	
18" BCI® 90 2.0 Joist	Span [ft]	12	1'-0"	1'-1"	1'-2"	1'-2"	1'-5"	1'-11"	2'-4"	2'-9"	3'-3"	3'-9"	4'-2"	4'-8"	5'-1"	5'-7"
		16	1'-0"	1'-1"	1'-2"	1'-4"	1'-11"	2'-7"	3'-2"	3'-8"	4'-5"	5'-0"	5'-7"	6'-3"	6'-10"	7'-5"
		20	1'-0"	1'-1"	1'-2"	1'-8"	2'-5"	3'-3"	4'-0"	4'-8"	5'-6"	6'-3"	7'-0"	7'-9"	8'-7"	9'-4"
		24	1'-0"	1'-1"	1'-2"	2'-0"	2'-11"	3'-10"	4'-9"	5'-7"	6'-7"	7'-6"	8'-5"	9'-4"	10'-3"	11'-2"
		28	1'-0"	1'-1"	1'-4"	2'-5"	3'-5"	4'-6"	5'-7"	6'-6"	7'-9"	8'-9"	9'-10"	10'-11"	12'-0"	13'-1"
Round Hole Diameter [in]		2	3	4	5	6	7	8	8 7/8	10	11	12	13	14	15	
Rectangular Hole Side [in]		-	-	-	-	-	-	-	2	3	5	6	7	8	10	
20" BCI® 90 2.0 Joist	Span [ft]	12	1'-0"	1'-1"	1'-2"	1'-2"	1'-3"	1'-6"	1'-11"	2'-3"	2'-9"	3'-2"	3'-7"	3'-11"	4'-4"	4'-9"
		16	1'-0"	1'-1"	1'-2"	1'-2"	1'-6"	2'-1"	2'-7"	3'-1"	3'-8"	4'-3"	4'-9"	5'-3"	5'-10"	6'-4"
		20	1'-0"	1'-1"	1'-2"	1'-3"	1'-11"	2'-7"	3'-3"	3'-10"	4'-7"	5'-3"	5'-11"	6'-7"	7'-4"	8'-0"
		24	1'-0"	1'-1"	1'-2"	1'-6"	2'-4"	3'-1"	3'-11"	4'-7"	5'-6"	6'-4"	7'-2"	7'-11"	8'-9"	9'-7"
		28	1'-0"	1'-1"	1'-2"	1'-9"	2'-8"	3'-8"	4'-7"	5'-5"	6'-6"	7'-5"	8'-4"	9'-3"	10'-3"	11'-2"

- Select a table row based on joist depth and the actual joist span rounded up to the nearest table span. Scan across the row to the column headed by the appropriate round hole diameter or rectangular hole side. Use the longest side of a rectangular hole. The table value is the closest that the centerline of the hole may be to the centerline of the nearest support.
- The entire web may be cut out. **DO NOT** cut the flanges. Holes apply to either single or multiple joists in repetitive member conditions.
- For multiple holes, the amount of uncut web between holes must equal at least twice the diameter (or longest side) of the largest hole.
- 1½" round knockouts in the web may be removed by using a short piece of metal pipe and hammer.
- Holes may be positioned vertically anywhere in the web. The joist may be set with the 1½" knockout holes turned either up or down.
- This table was designed to apply to the design conditions covered by tables elsewhere in this publication. Use the BC CALC® software to check other hole sizes or holes under other design conditions. It may be possible to exceed the limitations of this table by analyzing a specific application with the BC CALC® software.

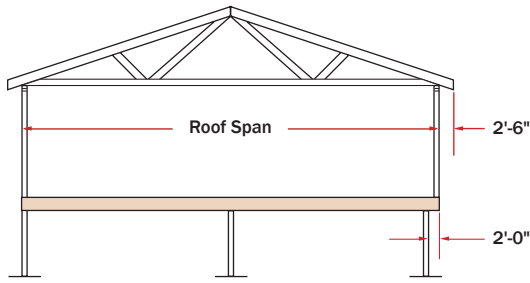

The detail to the right on this page shows the installation of cantilever reinforcement for load-bearing cantilevers up to a maximum length of 2'-0". Cantilevers longer than 2'-0" cannot be reinforced. **However, longer cantilevers with lower loads may be allowable without reinforcement. Analyze specific applications with the BC CALC® software.**

## PLYWOOD / OSB REINFORCEMENT (If Required per BC CALC® analysis)

### Analyze BCI® Load Bearing Cantilevers in BC CALC® Software

- 23/32" Min. x 48" long plywood / OSB rated sheathing must match the full depth of the BCI® Joist. Nail to the BCI® Joist with 8d nails at 6" o.c. and nail with 4-8d nails into backer block. When reinforcing both sides, stagger nails to limit splitting. Install with horizontal face grain.
- Contact Boise Cascade EWP Engineering for reinforcement requirements on BCI® Joist depths greater than 16".

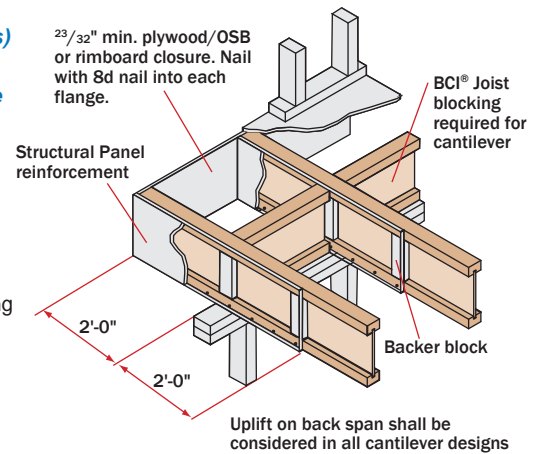

# Non-Load Bearing Wall Cantilever Details

BCI® Joists are intended only for applications that provide permanent protection from the weather.

Fasten the 2x8 minimum to the BCI® Joist by nailing through the backer block and joist web with 2 rows of 10d nails at 6" on center. Use 16d nails with BCI® 90 2.0 joists. Clinch all nails.

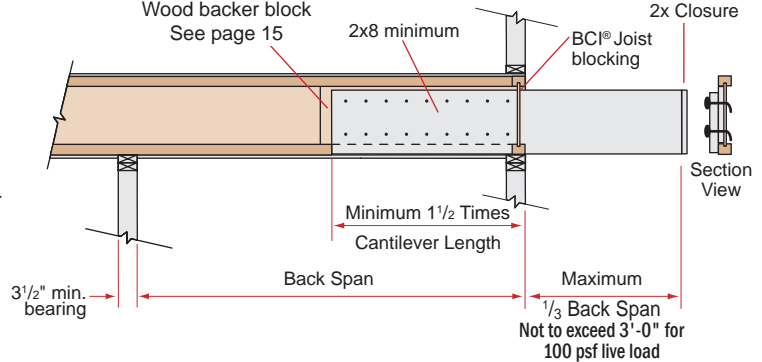
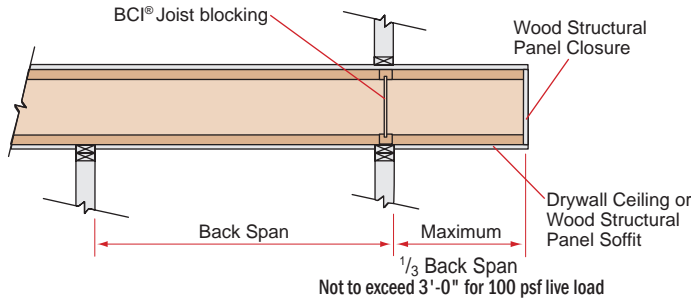

- These details apply to cantilevers with uniform loads only.
- It may be possible to exceed the limitations of these details by analyzing a specific application with the BC CALC® software.

# Web Stiffener Requirements

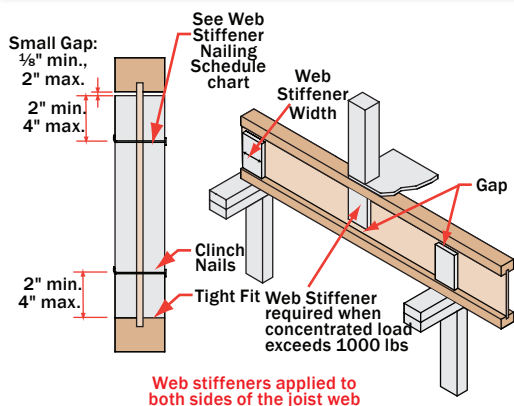

Web stiffeners applied to both sides of the joist web

Structural Panel Web Stiffener			
Series	Minimum Thickness		Minimum Width
	In Hanger	No Hanger	
5000 1.7	3/4"	5/8"	2 <sup>5</sup> / <sub>16</sub> "
6000 1.8	7/8"	3/4"	2 <sup>5</sup> / <sub>16</sub> "
6500 1.8	1"	3/4"	2 <sup>5</sup> / <sub>16</sub> "
60 2.0	7/8"	3/4"	2 <sup>5</sup> / <sub>16</sub> "
90 2.0	2x4 lumber (vertical)		

## NOTES

- **Web stiffeners required at all bearing locations for floor span tables on pages 5-13 (spans without web stiffeners are possible, analyze such conditions with BC Calc sizing software), optional for other applications except as noted below.**
- Web stiffeners are always required for all 18" and 20" BCI® joists at all bearing locations.
- Web stiffeners are always required in hangers that do not extend up to support the top flange of the BCI® Joist. Web stiffeners may be required with certain sloped or skewed hangers or to achieve uplift values. Refer to the hanger manufacturer's installation requirements.
- Web stiffeners are always required in certain roof applications. See *Roof Framing Details* on page 24.
- Web stiffeners are always required under concentrated loads that exceed 1000 pounds. Install the web stiffeners snug to the top flange in this situation. Follow the nailing schedule for intermediate bearings.
- Web stiffeners may be used to increase allowable reaction values. See *BCI® Design Properties* on page 33 or the BC CALC® software.

Web Stiffener Nailing Schedule			
BCI® Joist Series	Joist Depth	Bearing Location	
		End	Intermediate
5000 1.7	9 1/2"	2-8d	2-8d
	11 7/8"	2-8d	3-8d
	14"	2-8d	5-8d
6000 1.8	9 1/2"	2-8d	2-8d
	11 7/8"	2-8d	3-8d
	14"	2-8d	5-8d
6500 1.8	9 1/2"	2-8d	2-8d
	11 7/8"	2-8d	3-8d
	14"	2-8d	5-8d
60 2.0	11 7/8"	2-8d	3-8d
	14"	2-8d	5-8d
	16"	2-8d	6-8d
90 2.0	11 7/8"	3-16d	3-16d
	14"	5-16d	5-16d
	16"	6-16d	6-16d
	18"	7-16d	7-16d
	20"	8-16d	8-16d

## Allowable Uniform Floor Load (in pounds per lineal foot [PLF])

### 100% Load Duration

Span Length	BCI® 5000 1.7 Series 2" Flange Width								BCI® 6000 1.8 Series 2 <sup>5</sup> / <sub>16</sub> " Flange Width							
	9½" BCI® 5000 1.7		11⅞" BCI® 5000 1.7		14" BCI® 5000 1.7		16" BCI® 5000 1.7		9½" BCI® 6000 1.8		11⅞" BCI® 6000 1.8		14" BCI® 6000 1.8		16" BCI® 6000 1.8	
	Live Load	Total Load	Live Load	Total Load	Live Load	Total Load	Live Load	Total Load	Live Load	Total Load	Live Load	Total Load	Live Load	Total Load	Live Load	Total Load
6	-	280	-	300	-	313	-	316	-	320	-	333	-	346	-	353
7	-	240	-	257	-	268	-	271	-	274	-	285	-	297	-	302
8	-	210	-	225	-	235	-	237	-	240	-	250	-	260	-	265
9	-	186	-	200	-	208	-	211	-	213	-	222	-	231	-	235
10	151	168	-	180	-	188	-	190	175	192	-	200	-	208	-	212
11	117	152	-	163	-	170	-	172	135	174	-	181	-	189	-	192
12	91	136	146	150	-	156	-	158	107	160	-	166	-	173	-	176
13	73	116	117	138	-	144	-	146	85	147	138	153	-	160	-	163
14	59	100	95	128	-	134	-	135	69	129	113	142	-	148	-	151
15	48	87	78	112	115	125	-	126	57	112	93	133	135	138	-	141
16	40	76	65	98	96	116	-	118	47	95	78	125	113	130	-	132
17			55	87	80	103	108	111	40	80	65	112	95	122	-	124
18			47	77	68	92	92	105			56	100	81	115	108	117
19			40	69	58	82	78	94			48	89	70	106	93	111
20					50	74	68	85			41	81	60	96	80	106
21					44	67	59	77					52	87	70	99
22							51	70					46	79	61	90

- Total Load values are limited by shear, moment, or deflection equal to L/240.
- Live Load values are limited by deflection equal to L/480. For deflection limits of L/360 and L/960, multiply the Live Load values by 1.33 and 0.50 respectively.
- Both the Total Load and Live Load columns must be checked. Where a Live Load value is not shown, the Total Load value will control.
- Table values apply to either simple or multiple span joists. Span is measured center to center of the minimum required bearing length. Analyze multiple span joists with the BC CALC® software if the length of any span is less than half the length of an adjacent span.
- Table values do not consider composite action from gluing and nailing floor sheathing (composite action is considered in floor span tables on page 4-13).
- Total Load values assume minimum bearing lengths without web stiffeners for joist depths of 16 inches and less. 18 and 20 inch joists require web stiffeners.
- This table was designed to apply to a broad range of applications. It may be possible to exceed the limitations of this table by analyzing a specific application with the BC CALC® software.

## Allowable Uniform Floor Load (in pounds per lineal foot [PLF])

### 100% Load Duration

Span Length	BCI® 6500 1.8 Series 2 <sup>9</sup> / <sub>16</sub> " Flange Width								BCI® 60 2.0 Series 2 <sup>5</sup> / <sub>16</sub> " Flange Width					
	9½" BCI® 6500 1.8		11 <sup>7</sup> / <sub>8</sub> " BCI® 6500 1.8		14" BCI® 6500 1.8		16" BCI® 6500 1.8		11 <sup>7</sup> / <sub>8</sub> " BCI® 60 2.0		14" BCI® 60 2.0		16" BCI® 60 2.0	
	Live Load	Total Load	Live Load	Total Load	Live Load	Total Load	Live Load	Total Load	Live Load	Total Load	Live Load	Total Load	Live Load	Total Load
6	-	320	-	333	-	346	-	353	-	366	-	366	-	366
7	-	274	-	285	-	297	-	302	-	314	-	314	-	314
8	-	240	-	250	-	260	-	265	-	275	-	275	-	275
9	-	213	-	222	-	231	-	235	-	244	-	244	-	244
10	190	192	-	200	-	208	-	212	-	220	-	220	-	220
11	147	174	-	181	-	189	-	192	-	200	-	200	-	200
12	116	160	-	166	-	173	-	176	-	183	-	183	-	183
13	93	147	152	153	-	160	-	163	-	169	-	169	-	169
14	76	137	124	142	-	148	-	151	149	157	-	157	-	157
15	62	124	103	133	-	138	-	141	123	146	-	146	-	146
16	52	104	85	125	123	130	-	132	103	137	-	137	-	137
17	44	88	72	117	104	122	-	124	87	129	125	129	-	129
18			61	110	88	115	117	117	74	122	106	122	-	122
19			52	99	76	109	101	111	63	115	92	115	-	115
20			45	89	65	104	87	106	55	110	79	110	105	110
21					57	96	76	100	48	96	69	104	92	104
22					50	88	66	96	42	84	60	100	81	100
23					44	80	58	92			53	95	71	95
24							52	84			47	91	63	91
25							46	77			42	84	56	88
26							41	72					50	84
27													45	81
28													40	78
29														
30														



## Allowable Uniform Floor Load (in pounds per lineal foot [PLF])

### 100% Load Duration

Span Length	BCI® 90 2.0 Series 3½" Flange Width									
	11⅞" BCI® 90 2.0		14" BCI® 90 2.0		16" BCI® 90 2.0		18" BCI® 90 2.0		20" BCI® 90 2.0	
	Live Load	Total Load	Live Load	Total Load	Live Load	Total Load	Live Load	Total Load	Live Load	Total Load
6	-	450	-	453	-	456	-	553	-	573
7	-	385	-	388	-	391	-	474	-	491
8	-	337	-	340	-	342	-	415	-	430
9	-	300	-	302	-	304	-	368	-	382
10	-	270	-	272	-	274	-	332	-	344
11	-	245	-	247	-	249	-	301	-	312
12	-	225	-	226	-	228	-	276	-	286
13	-	207	-	209	-	210	-	255	-	264
14	-	192	-	194	-	195	-	237	-	245
15	174	180	-	181	-	182	-	221	-	229
16	146	168	-	170	-	171	-	207	-	215
17	124	158	-	160	-	161	-	195	-	202
18	106	150	150	151	-	152	-	184	-	191
19	91	142	129	143	-	144	-	174	-	181
20	79	135	112	136	-	137	-	166	-	172
21	69	128	98	129	-	130	-	158	-	163
22	61	122	86	123	115	124	146	150	-	156
23	53	107	76	118	101	119	129	144	-	149
24	47	95	68	113	90	114	115	138	-	143
25	42	85	60	108	80	109	103	132	128	137
26			54	104	72	105	92	127	115	132
27			48	97	65	101	83	122	104	127
28			44	88	58	97	75	118	94	122
29					53	94	68	114	85	118
30					48	91	62	110	77	114

- Total Load values are limited by shear, moment, or deflection equal to L/240.
- Live Load values are limited by deflection equal to L/480. For deflection limits of L/360 and L/960, multiply the Live Load values by 1.33 and 0.50 respectively.
- Both the Total Load and Live Load columns must be checked. Where a Live Load value is not shown, the Total Load value will control.
- Table values apply to either simple or multiple span joists. Span is measured center to center of the minimum required bearing length. Analyze multiple span joists with the

BC CALC® software if the length of any span is less than half the length of an adjacent span.

- Table values do not consider composite action from gluing and nailing floor sheathing (composite action is considered in floor span tables on page 4-13).
- Total Load values assume minimum bearing lengths without web stiffeners for joist depths of 16 inches and less. 18 and 20 inch joists require web stiffeners.
- This table was designed to apply to a broad range of applications. It may be possible to exceed the limitations of this table by analyzing a specific application with the BC CALC® software.

## BCI® Rafters

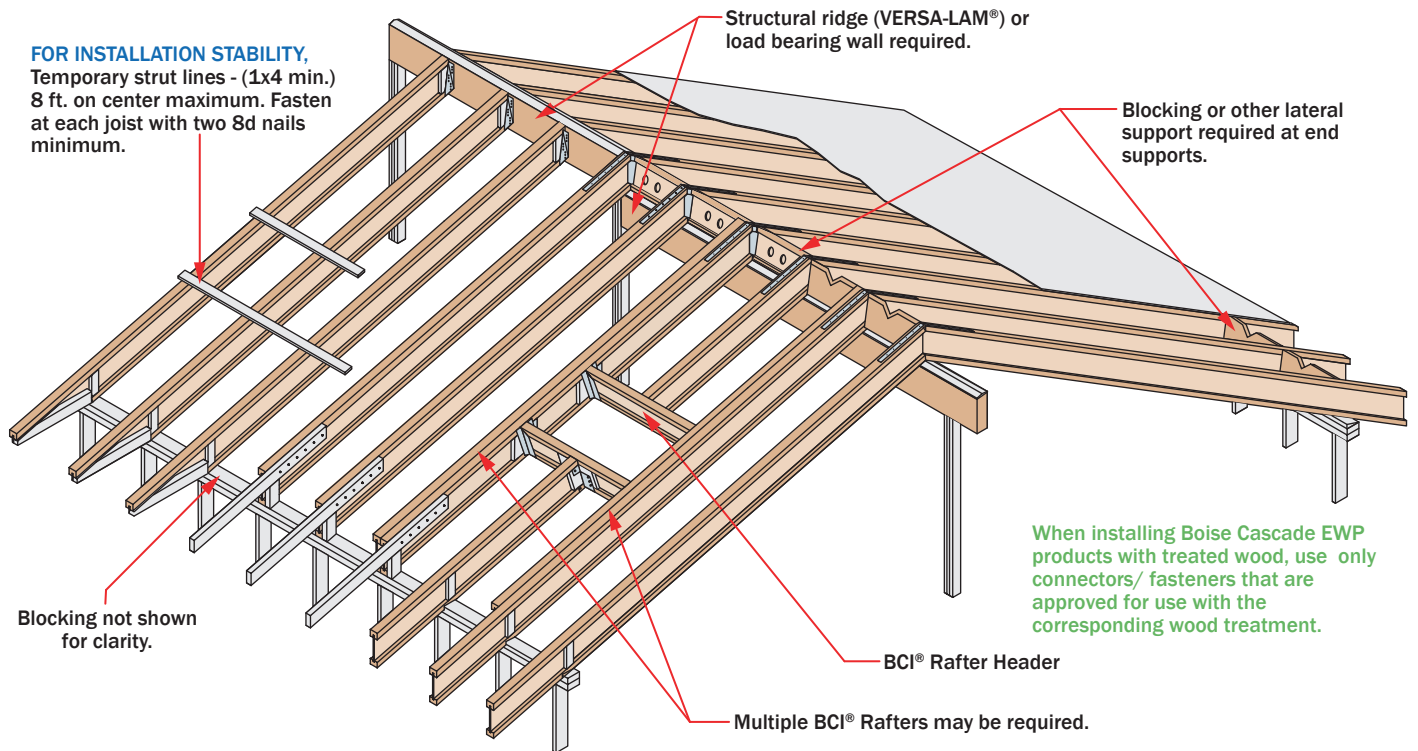
**SAFETY WARNING**

**DO NOT ALLOW WORKERS ON BCI® JOISTS UNTIL ALL HANGERS, BCI® RIM JOISTS, RIM BOARDS, BCI® BLOCKING PANELS, X-BRACING AND TEMPORARY 1x4 STRUT LINES ARE INSTALLED AS SPECIFIED BELOW.**

**SERIOUS ACCIDENTS CAN RESULT FROM INSUFFICIENT ATTENTION TO PROPER BRACING DURING CONSTRUCTION. ACCIDENTS CAN BE AVOIDED UNDER NORMAL CONDITIONS BY FOLLOWING THESE GUIDELINES:**

- Build a braced end wall at the end of the bay, or permanently install the first eight feet of BCI® Joists and the first course of sheathing. As an alternate, temporary sheathing may be nailed to the first four feet of BCI® Joists at the end of the bay.
- All hangers, BCI® rim joists, rim boards, BCI® blocking panels, and x-bracing must be completely installed and properly nailed as each BCI® Joist is set.
- Install temporary 1x4 strut lines at no more than eight feet on center as additional BCI® Joists are set. Nail the strut lines to the sheathed area, or braced end wall, and to each BCI® Joist with two 8d nails.
- The ends of cantilevers must be temporarily secured by strut lines on both the top and bottom flanges.
- Straighten the BCI® Joists to within ½ inch of true alignment before attaching strut lines and sheathing.
- Remove the temporary strut lines only as required to install the permanent sheathing.
- Failure to install temporary bracing may result in sideways buckling or roll-over under light construction loads.



## Additional roof framing details available with BC FRAMER® software (see page 43)

**R01**

2x beveled plate for slope greater than 1/4/12.

Simpson VPA or USP TMP connectors or equal can be used in lieu of beveled plate for slopes from 3/12 to 12/12.

**R02**

Rimboard / VERSA-LAM Ventilation "V" cut: 1/3 of length, 1/2 of depth

2x4 blocking for soffit support

**R03**

Rimboard / VERSA-LAM® blocking. Ventilation "V" cut: 1/3 of length, 1/2 of depth

Flange of BCI® Joists may be birdsmouth cut only at the low end of the joist. Birds-mouth cut BCI® Joist must bear fully on plate, web stiffener required each side.

2'-6" max.

**R04**

10d nails at 6" o.c.

2x4 one side for 135 PLF max. 2x6 one side for 240 PLF max.

Backer block. Thickness per corresponding BCI® series.

2x block

BCI® blocking Holes cut for ventilation.

4'-0" horiz.

2'-6" horiz.

**R05**

Simpson or USP LSTA24 strap, nailing per governing building code.

VERSALAM® LVL support beam.

BCI® blocking Holes cut for ventilation.

Double-beveled wood plate.

Blocking on both sides of ridge may be required for shear transfer per design professional of record

**R06**

Simpson or USP LSTA24 strap where slope exceeds 7/12 (straps may be required for lower slopes in high-wind areas). Nailing per governing building code.

VERSALAM® LVL support beam.

Beveled web stiffener on each side.

Simpson LSSUI or USP TMU hanger.

**R07**

Joist Hanger

Backer block (minimum 12" wide). Nail with 10-10d nails.

Filler block. Nail with 10-10d nails.

Backer block required where top flange joist hanger load exceeds 250 lbs. Install tight to top flange.

**R11**

Double joist may be required when L exceeds rafter spacing.

Blocking as required.

Nail outrigger through BCI® web.

2" x \_ outrigger notched around BCI® top flange. Outrigger spacing no greater than 24" on-center.

End Wall.

L (2'-0" max.)

**DN05**

**DO NOT** bevel-cut joist beyond inside face of wall, except for specific conditions in details shown on pages 15 and 24 of this guide.

### LATERAL SUPPORT

- BCI® Joists must be laterally supported at end supports (including supports adjacent to overhangs) with hangers, rimboard, or blocking (VERSA-LAM®, Boise Cascade Rimboard or BCI® Joist). Metal cross bracing or other x-bracing provides adequate lateral support for BCI® Joists, consult governing building code for roof diaphragm connection provisions.

### MINIMUM BEARING LENGTH FOR BCI® JOISTS

- Minimum end bearing: 1½" for BCI® 5000, 6000 & 6500; 1¾" for BCI® 60 & 90. 3½" is required at cantilever and intermediate supports.
- Longer bearing lengths allow higher reaction values. Refer to the building code evaluation report or the BC CALC® software.

### NAILING REQUIREMENTS

- BCI® rim joist, rim board or closure panel to BCI® joist:
  - Rims or closure panel 1¾ inches thick and less: 2-8d nails, one each in the top and bottom flange.
  - BCI® 5000 rim joist: 2-10d box nails, one each in the top and bottom flange.
  - BCI® 6000, 60 rim joist: 2-16d box nails, one each in the top and bottom flange.
  - BCI® 6500, 90 rim joist: Toe-nail top flange to rim joist with 2-10d box nails, one each side of flange.
- BCI® rim joist, rim board or BCI® blocking panel to support:
  - Min. 8d nails @ 6" o.c. per IRC.
  - Connection per design professional of record's specification for shear transfer.

- BCI® joist to support:
  - 2-8d nails, one on each side of the web, placed 1½ inches minimum from the end of the BCI® Joist to limit splitting.
- Sheathing to BCI® joist:
  - Prescriptive residential roof sheathing nailing requires 8d common nails @ 6" o.c. on edges and @ 12" o.c. in the field (IRC Table R602.3(1)).
  - See closest allowable nail spacing limits on page 24 for floor diaphragm nailing specified at closer spacing than IRC.
  - Maximum nail spacing for minimum lateral stability: 18" for BCI® 5000, 24" for larger BCI® joist series.
  - 14 gauge staples may be substituted for 8d nails if the staples penetrate at least 1 inch into the joist.
  - Wood screws may be acceptable, contact local building official and/or Boise Cascade EWP Engineering for further information.

### BACKER AND FILLER BLOCK DIMENSIONS

Series	Backer Block Thickness	Filler Block Thickness
5000 1.7	¾" or ½" wood panels	Two ¾" wood panels or 2x_
6000 1.8	1½" or two ¾" wood panels	2x_ + 7/16" or ½" wood panel
6500 1.8	1½" or two ¾" wood panels	2x_ + 5/8" or ¾" wood panel
60 2.0	1½" or two ¾" wood panels	2x_ + 7/16" or ½" wood panel
90 2.0	2x_ lumber	Double 2x_ lumber

- Cut backer and filler blocks to a maximum depth equal to the web depth minus ¼" to avoid a forced fit.

### WEB STIFFENER REQUIREMENTS

- See Web Stiffener Requirements on page 18.

### PROTECT BCI® JOISTS FROM THE WEATHER

- BCI® Joists are intended only for applications that provide permanent protection from the weather. Bundles of BCI® Joists should be covered and stored off of the ground on stickers.

### MAXIMUM SLOPE

- Unless otherwise noted, all roof details are valid for slopes of 12 in 12 or less.

### VENTILATION

- The 1½ inch, pre-stamped knock-out holes spaced at 12 inches on center along the BCI® Joist may all be knocked out and used for cross ventilation. Deeper joists than what is structurally needed may be advantageous in ventilation design. Consult local building official and/or ventilation specialist for specific ventilation requirements.

### BIRDSMOUTH CUTS

- BCI® Joists may be birdsmouth cut only at the low end support. BCI® joists with birdsmouth cuts may cantilever up to 2'-6" past the low end support. The bottom flange must sit fully on the support and may not overhang the inside face of the support. High end supports and intermediate supports may not be birdsmouth cut.



Maximum clear span in feet and inches, based on horizontal spans.

## 115% and 125% Load Duration

		BCI® 5000 1.7 Series 2" Flange Width													
		Live Load [psf]	Dead Load [psf]	9½" BCI® 5000 1.7			11⅞" BCI® 5000 1.7			14" BCI® 5000 1.7			16" BCI® 5000 1.7		
				4/12 or Less	4/12 to 8/12	8/12 to 12/12	4/12 or Less	4/12 to 8/12	8/12 to 12/12	4/12 or Less	4/12 to 8/12	8/12 to 12/12	4/12 or Less	4/12 to 8/12	8/12 to 12/12
16" o.c.	Non-Snow 125%	20	10	21'-10"	20'-7"	19'-1"	25'-11"	24'-5"	22'-8"	29'-6"	27'-10"	25'-10"	32'-1"	30'-10"	28'-8"
		20	15	20'-8"	19'-5"	17'-11"	24'-6"	23'-0"	21'-3"	27'-8"	26'-3"	24'-3"	29'-7"	28'-9"	26'-10"
		20	20	19'-9"	18'-6"	17'-0"	23'-5"	21'-11"	20'-2"	25'-10"	25'-0"	22'-11"	27'-8"	26'-8"	25'-5"
	Snow 115%	25	10	20'-9"	19'-7"	18'-3"	24'-6"	23'-3"	21'-8"	26'-8"	26'-1"	24'-8"	28'-6"	27'-11"	27'-2"
		25	15	19'-9"	18'-7"	17'-3"	22'-10"	22'-1"	20'-5"	24'-10"	24'-3"	23'-4"	26'-7"	25'-11"	25'-0"
		30	10	19'-10"	18'-9"	17'-6"	22'-11"	22'-3"	20'-9"	24'-11"	24'-6"	23'-8"	26'-8"	26'-2"	25'-7"
		30	15	19'-0"	17'-11"	16'-8"	21'-6"	21'-0"	19'-9"	23'-5"	22'-11"	22'-2"	25'-1"	24'-6"	23'-8"
		40	10	18'-0"	17'-4"	16'-4"	20'-6"	20'-2"	19'-4"	22'-4"	22'-0"	21'-7"	23'-10"	23'-6"	23'-0"
		40	15	17'-2"	16'-10"	15'-8"	19'-6"	19'-1"	18'-7"	21'-3"	20'-10"	20'-3"	22'-8"	22'-3"	21'-8"
		50	10	16'-6"	16'-0"	15'-2"	18'-8"	18'-6"	18'-0"	20'-4"	20'-1"	19'-9"	21'-9"	21'-6"	21'-2"
50	15	15'-10"	15'-6"	14'-10"	17'-11"	17'-7"	17'-3"	19'-6"	19'-2"	18'-9"	20'-10"	20'-6"	20'-1"		
19.2" o.c.	Non-Snow 125%	20	10	20'-6"	19'-4"	18'-0"	24'-4"	22'-11"	21'-4"	27'-5"	26'-2"	24'-3"	29'-3"	28'-7"	26'-11"
		20	15	19'-5"	18'-3"	16'-10"	23'-0"	21'-8"	20'-0"	25'-3"	24'-6"	22'-9"	27'-0"	26'-2"	25'-2"
		20	20	18'-6"	17'-4"	15'-11"	21'-8"	20'-7"	18'-11"	23'-7"	22'-9"	21'-7"	25'-2"	24'-4"	23'-3"
	Snow 115%	25	10	19'-6"	18'-5"	17'-2"	22'-4"	21'-10"	20'-4"	24'-4"	23'-10"	23'-2"	26'-0"	25'-6"	24'-9"
		25	15	18'-4"	17'-6"	16'-2"	20'-10"	20'-3"	19'-2"	22'-8"	22'-1"	21'-4"	24'-3"	23'-7"	22'-9"
		30	10	18'-5"	17'-8"	16'-5"	20'-11"	20'-6"	19'-6"	22'-9"	22'-4"	21'-10"	24'-4"	23'-11"	23'-4"
		30	15	17'-4"	16'-10"	15'-8"	19'-7"	19'-2"	18'-6"	21'-5"	20'-11"	20'-3"	22'-10"	22'-4"	21'-7"
		40	10	16'-6"	16'-3"	15'-4"	18'-8"	18'-5"	18'-0"	20'-4"	20'-1"	19'-8"	21'-9"	21'-5"	21'-0"
		40	15	15'-8"	15'-4"	14'-8"	17'-9"	17'-5"	16'-11"	19'-4"	19'-0"	18'-6"	20'-8"	20'-3"	19'-9"
		50	10	15'-0"	14'-10"	14'-3"	17'-0"	16'-10"	16'-7"	18'-7"	18'-4"	18'-0"	19'-10"	19'-7"	19'-3"
50	15	14'-5"	14'-2"	13'-10"	16'-4"	16'-1"	15'-8"	17'-10"	17'-6"	17'-1"	19'-0"	18'-9"	18'-3"		
24" o.c.	Non-Snow 125%	20	10	19'-0"	17'-11"	16'-8"	22'-5"	21'-3"	19'-9"	24'-6"	23'-11"	22'-6"	26'-2"	25'-6"	24'-9"
		20	15	18'-0"	16'-11"	15'-7"	20'-9"	20'-0"	18'-6"	22'-7"	21'-11"	21'-0"	24'-2"	23'-5"	22'-6"
		20	20	17'-1"	16'-1"	14'-9"	19'-4"	18'-8"	17'-6"	21'-1"	20'-4"	19'-5"	22'-6"	21'-9"	20'-9"
	Snow 115%	25	10	17'-7"	17'-1"	15'-11"	19'-11"	19'-6"	18'-10"	21'-9"	21'-3"	20'-8"	23'-3"	22'-9"	22'-1"
		25	15	16'-5"	15'-11"	15'-0"	18'-7"	18'-1"	17'-5"	20'-3"	19'-9"	19'-0"	21'-8"	21'-1"	20'-4"
		30	10	16'-5"	16'-2"	15'-3"	18'-8"	18'-4"	17'-10"	20'-4"	20'-0"	19'-6"	21'-9"	21'-4"	20'-10"
		30	15	15'-5"	15'-1"	14'-6"	17'-6"	17'-1"	16'-7"	19'-1"	18'-8"	18'-1"	20'-5"	19'-11"	19'-4"
		40	10	14'-8"	14'-6"	14'-2"	16'-8"	16'-5"	16'-1"	18'-2"	17'-11"	17'-7"	19'-5"	19'-2"	18'-9"
		40	15	14'-0"	13'-8"	13'-4"	15'-10"	15'-7"	15'-2"	17'-3"	16'-11"	16'-6"	18'-6"	18'-1"	17'-8"
		50	10	13'-5"	13'-3"	13'-0"	15'-3"	15'-0"	14'-9"	16'-7"	16'-5"	16'-1"	17'-9"	17'-6"	16'-11"
50	15	12'-10"	12'-8"	12'-4"	14'-7"	14'-4"	14'-0"	15'-11"	15'-8"	14'-11"	16'-6"	16'-0"	15'-3"		
32" o.c.	Non-Snow 125%	20	10	17'-1"	16'-3"	15'-1"	19'-5"	18'-11"	17'-10"	21'-2"	20'-8"	20'-0"	22'-7"	22'-1"	21'-4"
		20	15	15'-9"	15'-3"	14'-1"	17'-11"	17'-4"	16'-8"	19'-6"	18'-11"	18'-2"	20'-10"	20'-3"	19'-5"
		20	20	14'-9"	14'-3"	13'-4"	16'-8"	16'-1"	15'-5"	18'-2"	17'-7"	16'-9"	19'-6"	18'-9"	17'-11"
	Snow 115%	25	10	15'-2"	14'-11"	14'-4"	17'-3"	16'-10"	16'-5"	18'-9"	18'-5"	17'-11"	20'-1"	19'-8"	19'-1"
		25	15	14'-2"	13'-9"	13'-3"	16'-1"	15'-8"	15'-1"	17'-6"	17'-1"	16'-5"	18'-9"	18'-3"	17'-7"
		30	10	14'-2"	13'-11"	13'-7"	16'-1"	15'-10"	15'-5"	17'-7"	17'-3"	16'-10"	18'-9"	18'-5"	18'-0"
		30	15	13'-4"	13'-0"	12'-7"	15'-2"	14'-9"	14'-4"	16'-6"	16'-1"	15'-7"	17'-8"	17'-0"	15'-11"
		40	10	12'-8"	12'-6"	12'-3"	14'-5"	14'-2"	13'-11"	15'-8"	15'-4"	14'-9"	16'-1"	15'-8"	15'-0"
		40	15	12'-1"	11'-10"	11'-6"	13'-8"	13'-1"	12'-5"	14'-3"	13'-9"	13'-0"	14'-7"	14'-0"	13'-3"
		50	10	11'-7"	11'-5"	11'-0"	12'-7"	12'-3"	11'-10"	13'-2"	12'-10"	12'-5"	13'-5"	13'-1"	12'-8"
50	15	10'-9"	10'-5"	9'-11"	11'-6"	11'-2"	10'-8"	12'-1"	11'-8"	11'-1"	12'-4"	11'-11"	11'-4"		

- Tables are intended to be used for preliminary sizing of roof members only and not for final sizing. Tables are based on a uniformly loaded roof due to roof live or snow loads and dead load. Wind loading, unbalanced snow loading, snow drifting, sliding and surcharges, and roof-top mechanical units are NOT considered in the tables. The determination of such roof design loads is the responsibility of the project's design professional of record.
- Table values are limited by shear, moment, total load deflection equal to L/180 and live load deflection equal to L/240. Check the local building code for other deflection limits that may apply.
- Table values represent the most restrictive of simple or multiple span applications.
- Table values assume minimum bearing lengths without web stiffeners for joist depths of 16 inches and less. 18 and 20 inch joists require web stiffeners.
- This table was designed to apply to a broad range of applications. It may be possible to exceed the limitations of this table by analyzing a specific application with the BC CALC® software.
- Slope roof joists at least ¼" over 12" to minimize ponding.
- Allowable spans and loads shall be adjusted and checked for wind load as required by local building code.

# BCI® Roof Span Tables

Maximum clear span in feet and inches, based on horizontal spans.

## 115% and 125% Load Duration

			BCI® 6000 1.8 Series													
			2 <sup>5</sup> / <sub>16</sub> " Flange Width													
			9½" BCI® 6000 1.8			11⅞" BCI® 6000 1.8			14" BCI® 6000 1.8			16" BCI® 6000 1.8				
16" o.c.	Non-Snow 125%	Live Load [psf]	Dead Load [psf]	4/12 or Less	4/12 to 8/12	8/12 to 12/12	4/12 or Less	4/12 to 8/12	8/12 to 12/12	4/12 or Less	4/12 to 8/12	8/12 to 12/12	4/12 or Less	4/12 to 8/12	8/12 to 12/12	
				20	10	23'-2"	21'-10"	20'-3"	27'-7"	26'-0"	24'-2"	31'-5"	29'-7"	27'-6"	34'-9"	32'-9"
		20	15	21'-11"	20'-7"	19'-0"	26'-1"	24'-6"	22'-8"	29'-9"	27'-11"	25'-9"	32'-11"	30'-11"	28'-6"	
		20	20	20'-11"	19'-7"	18'-0"	24'-11"	23'-4"	21'-5"	28'-5"	26'-7"	24'-5"	31'-5"	29'-5"	27'-0"	
	Snow 115%	25	10	22'-0"	20'-9"	19'-4"	26'-2"	24'-9"	23'-0"	29'-10"	28'-2"	26'-3"	32'-5"	31'-2"	29'-0"	
		25	15	20'-11"	19'-9"	18'-3"	24'-11"	23'-6"	21'-9"	28'-3"	26'-9"	24'-10"	30'-3"	29'-5"	27'-5"	
		30	10	21'-0"	19'-11"	18'-7"	25'-0"	23'-8"	22'-1"	28'-4"	27'-0"	25'-2"	30'-4"	29'-9"	27'-10"	
		30	15	20'-1"	19'-0"	17'-7"	24'-0"	22'-7"	21'-0"	26'-8"	25'-9"	23'-11"	28'-6"	27'-10"	26'-6"	
		40	10	19'-1"	18'-4"	17'-3"	22'-9"	21'-10"	20'-7"	25'-5"	24'-11"	23'-6"	27'-2"	26'-9"	26'-0"	
		40	15	18'-9"	17'-9"	16'-7"	22'-2"	21'-2"	19'-9"	24'-2"	23'-8"	22'-6"	25'-10"	25'-4"	24'-8"	
		50	10	17'-8"	16'-11"	16'-1"	21'-1"	20'-2"	19'-2"	23'-2"	22'-11"	21'-10"	24'-9"	24'-6"	24'-1"	
		50	15	17'-8"	16'-10"	15'-9"	20'-4"	20'-0"	18'-9"	22'-2"	21'-10"	21'-4"	23'-9"	23'-4"	22'-10"	
	Non-Snow 125%	20	10	21'-9"	20'-6"	19'-0"	25'-11"	24'-5"	22'-8"	29'-6"	27'-10"	25'-10"	32'-8"	30'-10"	28'-7"	
		20	15	20'-7"	19'-4"	17'-10"	24'-6"	23'-0"	21'-3"	27'-11"	26'-3"	24'-3"	30'-8"	29'-0"	26'-10"	
		20	20	19'-7"	18'-4"	16'-11"	23'-4"	21'-11"	20'-2"	26'-8"	24'-11"	22'-11"	28'-8"	27'-7"	25'-5"	
		Snow 115%	25	10	20'-7"	19'-6"	18'-2"	24'-7"	23'-3"	21'-8"	27'-8"	26'-6"	24'-8"	29'-7"	28'-11"	27'-3"
			25	15	19'-8"	18'-6"	17'-2"	23'-5"	22'-1"	20'-5"	25'-9"	25'-1"	23'-4"	27'-7"	26'-10"	25'-9"
			30	10	19'-8"	18'-8"	17'-5"	23'-6"	22'-3"	20'-9"	25'-10"	25'-4"	23'-8"	27'-8"	27'-2"	26'-2"
			30	15	18'-11"	17'-10"	16'-7"	22'-4"	21'-3"	19'-9"	24'-4"	23'-9"	22'-6"	26'-0"	25'-5"	24'-7"
			40	10	17'-11"	17'-2"	16'-3"	21'-3"	20'-6"	19'-4"	23'-2"	22'-10"	22'-1"	24'-9"	24'-5"	23'-11"
			40	15	17'-8"	16'-8"	15'-7"	20'-2"	19'-10"	18'-7"	22'-0"	21'-7"	21'-0"	23'-6"	23'-1"	22'-6"
		50	10	16'-7"	15'-11"	15'-1"	19'-5"	19'-0"	18'-0"	21'-1"	20'-10"	20'-6"	22'-7"	22'-4"	21'-11"	
		50	15	16'-4"	15'-9"	14'-9"	18'-7"	18'-3"	17'-7"	20'-3"	19'-11"	19'-5"	21'-8"	21'-3"	20'-10"	
	Non-Snow 125%	20	10	20'-1"	19'-0"	17'-7"	24'-0"	22'-7"	21'-0"	27'-4"	25'-9"	23'-11"	29'-9"	28'-6"	26'-6"	
		20	15	19'-0"	17'-11"	16'-6"	22'-8"	21'-4"	19'-8"	25'-8"	24'-4"	22'-5"	27'-5"	26'-7"	24'-10"	
		20	20	18'-2"	17'-0"	15'-8"	21'-8"	20'-3"	18'-8"	23'-11"	23'-1"	21'-3"	25'-7"	24'-9"	23'-6"	
		Snow 115%	25	10	19'-1"	18'-1"	16'-10"	22'-8"	21'-6"	20'-0"	24'-8"	24'-2"	22'-10"	26'-5"	25'-10"	25'-2"
			25	15	18'-2"	17'-2"	15'-10"	21'-2"	20'-5"	18'-11"	23'-0"	22'-5"	21'-7"	24'-8"	24'-0"	23'-2"
			30	10	18'-3"	17'-3"	16'-2"	21'-2"	20'-7"	19'-3"	23'-1"	22'-8"	21'-11"	24'-9"	24'-3"	23'-8"
			30	15	17'-6"	16'-6"	15'-4"	19'-11"	19'-6"	18'-3"	21'-9"	21'-3"	20'-6"	23'-3"	22'-8"	21'-11"
			40	10	16'-7"	15'-11"	15'-0"	19'-0"	18'-8"	17'-11"	20'-8"	20'-4"	20'-0"	22'-1"	21'-9"	21'-4"
			40	15	15'-11"	15'-5"	14'-5"	18'-0"	17'-8"	17'-2"	19'-8"	19'-3"	18'-9"	21'-0"	20'-7"	19'-8"
		50	10	15'-3"	14'-8"	14'-0"	17'-4"	17'-1"	16'-8"	18'-10"	18'-8"	18'-4"	19'-10"	19'-5"	18'-9"	
		50	15	14'-7"	14'-4"	13'-8"	16'-7"	16'-4"	15'-11"	17'-11"	17'-4"	16'-6"	18'-3"	17'-8"	16'-10"	
	Non-Snow 125%	20	10	18'-2"	17'-2"	15'-11"	21'-8"	20'-6"	19'-0"	24'-1"	23'-4"	21'-8"	25'-9"	25'-1"	24'-0"	
		20	15	17'-3"	16'-2"	14'-11"	20'-4"	19'-4"	17'-10"	22'-2"	21'-6"	20'-4"	23'-9"	23'-0"	22'-1"	
		20	20	16'-5"	15'-5"	14'-2"	19'-0"	18'-4"	16'-10"	20'-8"	20'-0"	19'-1"	22'-2"	21'-4"	20'-4"	
		Snow 115%	25	10	17'-3"	16'-4"	15'-3"	19'-7"	19'-2"	18'-2"	21'-4"	20'-11"	20'-4"	22'-10"	22'-4"	21'-9"
			25	15	16'-1"	15'-6"	14'-4"	18'-3"	17'-9"	17'-2"	19'-11"	19'-5"	18'-8"	21'-4"	20'-9"	19'-6"
			30	10	16'-2"	15'-8"	14'-7"	18'-4"	18'-0"	17'-5"	20'-0"	19'-7"	19'-2"	21'-4"	21'-0"	20'-5"
			30	15	15'-2"	14'-10"	13'-10"	17'-3"	16'-10"	16'-3"	18'-9"	18'-4"	17'-3"	19'-8"	18'-9"	17'-7"
			40	10	14'-5"	14'-3"	13'-7"	16'-5"	16'-2"	15'-8"	17'-6"	17'-0"	16'-4"	17'-10"	17'-4"	16'-8"
			40	15	13'-9"	13'-5"	13'-0"	15'-2"	14'-7"	13'-10"	15'-10"	15'-2"	14'-5"	16'-1"	15'-6"	14'-8"
		50	10	13'-2"	13'-0"	12'-8"	14'-0"	13'-8"	13'-2"	14'-7"	14'-2"	13'-9"	14'-10"	14'-6"	14'-0"	
		50	15	12'-4"	11'-11"	11'-4"	12'-10"	12'-5"	11'-10"	13'-4"	12'-11"	12'-4"	13'-8"	13'-2"	12'-7"	

- Tables are intended to be used for preliminary sizing of roof members only and not for final sizing. Tables are based on a uniformly loaded roof due to roof live or snow loads and dead load. Wind loading, unbalanced snow loading, snow drifting, sliding and surcharges, and roof-top mechanical units are NOT considered in the tables. The determination of such roof design loads is the responsibility of the project's design professional of record.
- Table values are limited by shear, moment, total load deflection equal to L/180 and live load deflection equal to L/240. Check the local building code for other deflection limits that may apply.
- Table values represent the most restrictive of simple or multiple span applications.
- Table values assume minimum bearing lengths without web stiffeners for joist depths of 16 inches and less. 18 and 20 inch joists require web stiffeners.
- This table was designed to apply to a broad range of applications. It may be possible to exceed the limitations of this table by analyzing a specific application with the BC CALC® software.
- Slope roof joists at least ¼" over 12" to minimize ponding.
- Allowable spans and loads shall be adjusted and checked for wind load as required by local building code.

Maximum clear span in feet and inches, based on horizontal spans.

## 115% and 125% Load Duration

			BCI® 6500 1.8 Series 2 <sup>9</sup> / <sub>16</sub> " Flange Width													
			9½" BCI® 6500 1.8			11⅞" BCI® 6500 1.8			14" BCI® 6500 1.8			16" BCI® 6500 1.8				
		Live Load [psf]	Dead Load [psf]	4/12 or Less	4/12 to 8/12	8/12 to 12/12	4/12 or Less	4/12 to 8/12	8/12 to 12/12	4/12 or Less	4/12 to 8/12	8/12 to 12/12	4/12 or Less	4/12 to 8/12	8/12 to 12/12	
16" o.c.	Non-Snow 125%	20	10	23'-11"	22'-7"	20'-11"	28'-5"	26'-10"	24'-11"	32'-5"	30'-6"	28'-4"	35'-10"	33'-9"	31'-4"	
		20	15	22'-8"	21'-3"	19'-8"	26'-11"	25'-4"	23'-4"	30'-8"	28'-10"	26'-7"	33'-11"	31'-10"	29'-5"	
		20	20	21'-7"	20'-3"	18'-7"	25'-8"	24'-1"	22'-1"	29'-3"	27'-5"	25'-2"	32'-4"	30'-3"	27'-10"	
	Snow 115%	25	10	22'-8"	21'-6"	20'-0"	27'-0"	25'-6"	23'-9"	30'-9"	29'-1"	27'-1"	34'-0"	32'-2"	29'-11"	
		25	15	21'-8"	20'-5"	18'-11"	25'-9"	24'-3"	22'-5"	29'-4"	27'-7"	25'-7"	31'-10"	30'-6"	28'-3"	
		30	10	21'-8"	20'-7"	19'-2"	25'-10"	24'-5"	22'-10"	29'-5"	27'-10"	26'-0"	31'-11"	30'-9"	28'-9"	
		30	15	20'-10"	19'-8"	18'-3"	24'-9"	23'-4"	21'-8"	28'-1"	26'-7"	24'-8"	30'-0"	29'-4"	27'-4"	
		40	10	19'-9"	18'-11"	17'-10"	23'-6"	22'-6"	21'-3"	26'-9"	25'-8"	24'-3"	28'-7"	28'-2"	26'-9"	
		40	15	19'-5"	18'-5"	17'-2"	23'-1"	21'-11"	20'-5"	25'-5"	24'-11"	23'-3"	27'-2"	26'-8"	25'-8"	
		50	10	18'-3"	17'-6"	16'-8"	21'-9"	20'-10"	19'-10"	24'-5"	23'-9"	22'-7"	26'-1"	25'-9"	24'-11"	
		50	15	18'-3"	17'-5"	16'-3"	21'-5"	20'-9"	19'-4"	23'-5"	23'-0"	22'-0"	25'-0"	24'-7"	24'-0"	
	19.2" o.c.	Non-Snow 125%	20	10	22'-6"	21'-2"	19'-8"	26'-9"	25'-2"	23'-5"	30'-5"	28'-8"	26'-8"	33'-8"	31'-9"	29'-5"
			20	15	21'-3"	20'-0"	18'-5"	25'-4"	23'-9"	21'-11"	28'-10"	27'-1"	25'-0"	31'-10"	29'-11"	27'-7"
			20	20	20'-3"	19'-0"	17'-6"	24'-2"	22'-7"	20'-9"	27'-6"	25'-9"	23'-8"	30'-2"	28'-5"	26'-2"
Snow 115%		25	10	21'-4"	20'-2"	18'-9"	25'-4"	24'-0"	22'-4"	28'-11"	27'-4"	25'-5"	31'-1"	30'-2"	28'-1"	
		25	15	20'-4"	19'-2"	17'-9"	24'-2"	22'-9"	21'-1"	27'-2"	25'-11"	24'-0"	29'-0"	28'-3"	26'-7"	
		30	10	20'-4"	19'-4"	18'-0"	24'-3"	23'-0"	21'-5"	27'-3"	26'-2"	24'-5"	29'-1"	28'-7"	27'-0"	
		30	15	19'-6"	18'-5"	17'-1"	23'-3"	21'-11"	20'-4"	25'-7"	25'-0"	23'-2"	27'-5"	26'-9"	25'-8"	
		40	10	18'-6"	17'-9"	16'-9"	22'-1"	21'-2"	20'-0"	24'-4"	24'-0"	22'-9"	26'-1"	25'-8"	25'-2"	
		40	15	18'-3"	17'-3"	16'-1"	21'-3"	20'-7"	19'-2"	23'-2"	22'-9"	21'-10"	24'-9"	24'-4"	23'-8"	
		50	10	17'-1"	16'-5"	15'-7"	20'-5"	19'-7"	18'-7"	22'-3"	22'-0"	21'-2"	23'-9"	23'-6"	23'-1"	
		50	15	17'-1"	16'-4"	15'-3"	19'-7"	19'-3"	18'-2"	21'-4"	21'-0"	20'-6"	22'-10"	22'-2"	21'-2"	
24" o.c.		Non-Snow 125%	20	10	20'-10"	19'-8"	18'-3"	24'-9"	23'-4"	21'-8"	28'-2"	26'-7"	24'-8"	31'-2"	29'-5"	27'-4"
			20	15	19'-8"	18'-6"	17'-1"	23'-5"	22'-0"	20'-4"	26'-8"	25'-1"	23'-2"	28'-11"	27'-9"	25'-7"
			20	20	18'-9"	17'-7"	16'-2"	22'-4"	20'-11"	19'-3"	25'-3"	23'-10"	21'-11"	26'-11"	26'-0"	24'-3"
	Snow 115%	25	10	19'-9"	18'-8"	17'-5"	23'-6"	22'-3"	20'-8"	26'-0"	25'-4"	23'-7"	27'-10"	27'-3"	26'-1"	
		25	15	18'-10"	17'-9"	16'-5"	22'-3"	21'-1"	19'-6"	24'-3"	23'-7"	22'-3"	25'-11"	25'-3"	24'-4"	
		30	10	18'-10"	17'-10"	16'-8"	22'-4"	21'-3"	19'-10"	24'-4"	23'-11"	22'-7"	26'-0"	25'-7"	24'-11"	
		30	15	18'-1"	17'-1"	15'-10"	21'-0"	20'-4"	18'-10"	22'-10"	22'-4"	21'-6"	24'-5"	23'-11"	23'-1"	
		40	10	17'-1"	16'-5"	15'-6"	20'-0"	19'-7"	18'-6"	21'-9"	21'-5"	21'-0"	23'-3"	22'-11"	22'-3"	
		40	15	16'-9"	16'-0"	14'-11"	19'-0"	18'-7"	17'-9"	20'-8"	20'-4"	19'-3"	21'-7"	20'-9"	19'-8"	
		50	10	15'-10"	15'-2"	14'-5"	18'-3"	18'-0"	17'-3"	19'-6"	19'-0"	18'-5"	19'-10"	19'-5"	18'-9"	
		50	15	15'-5"	15'-1"	14'-1"	17'-3"	16'-8"	15'-11"	17'-11"	17'-4"	16'-6"	18'-3"	17'-8"	16'-10"	
	32" o.c.	Non-Snow 125%	20	10	18'-10"	17'-9"	16'-6"	22'-5"	21'-2"	19'-8"	25'-4"	24'-1"	22'-4"	27'-1"	26'-5"	24'-9"
			20	15	17'-10"	16'-9"	15'-5"	21'-2"	19'-11"	18'-5"	23'-4"	22'-8"	20'-11"	25'-0"	24'-3"	23'-2"
			20	20	17'-0"	15'-11"	14'-8"	20'-0"	18'-11"	17'-5"	21'-10"	21'-1"	19'-10"	23'-4"	22'-4"	20'-4"
Snow 115%		25	10	17'-10"	16'-11"	15'-9"	20'-8"	20'-1"	18'-9"	22'-6"	22'-0"	21'-4"	24'-1"	23'-7"	22'-11"	
		25	15	16'-11"	16'-0"	14'-10"	19'-3"	18'-9"	17'-8"	21'-0"	20'-5"	19'-2"	22'-2"	21'-0"	19'-6"	
		30	10	17'-0"	16'-2"	15'-1"	19'-4"	18'-11"	18'-0"	21'-0"	20'-8"	20'-1"	22'-3"	21'-6"	20'-5"	
		30	15	16'-0"	15'-5"	14'-4"	18'-2"	17'-8"	16'-7"	19'-4"	18'-5"	17'-3"	19'-8"	18'-9"	17'-7"	
		40	10	15'-2"	14'-10"	14'-1"	16'-10"	16'-4"	15'-8"	17'-6"	17'-0"	16'-5"	17'-10"	17'-4"	16'-8"	
		40	15	14'-6"	14'-0"	13'-3"	15'-2"	14'-7"	13'-10"	15'-10"	15'-2"	14'-5"	16'-1"	15'-6"	14'-8"	
		50	10	13'-5"	13'-1"	12'-8"	14'-0"	13'-8"	13'-2"	14'-7"	14'-2"	13'-9"	14'-10"	14'-6"	14'-0"	
		50	15	12'-4"	11'-11"	11'-4"	12'-10"	12'-5"	11'-10"	13'-4"	12'-11"	12'-4"	13'-8"	13'-2"	12'-7"	



# BCI® Roof Span Tables

Maximum clear span in feet and inches, based on horizontal spans.

## 115% and 125% Load Duration

			BCI® 60 2.0 Series 2 <sup>5</sup> / <sub>16</sub> " Flange Width									
			11 <sup>7</sup> / <sub>8</sub> " BCI® 60 2.0			14" BCI® 60 2.0			16" BCI® 60 2.0			
			Live Load [psf]	Dead Load [psf]	4/12 or Less	4/12 to 8/12	8/12 to 12/12	4/12 or Less	4/12 to 8/12	8/12 to 12/12	4/12 or Less	4/12 to 8/12
16" o.c.	Non-Snow 125%	20	10	30'-5"	28'-9"	26'-8"	34'-9"	32'-9"	30'-5"	38'-5"	36'-3"	33'-8"
		20	15	28'-10"	27'-1"	25'-0"	32'-10"	30'-10"	28'-6"	36'-5"	34'-2"	31'-7"
		20	20	27'-6"	25'-9"	23'-8"	31'-4"	29'-4"	27'-0"	34'-9"	32'-6"	29'-11"
	Snow 115%	25	10	28'-11"	27'-4"	25'-5"	32'-11"	31'-2"	29'-0"	36'-6"	34'-6"	32'-1"
		25	15	27'-7"	26'-0"	24'-1"	31'-5"	29'-7"	27'-5"	34'-10"	32'-9"	30'-4"
		30	10	27'-8"	26'-2"	24'-5"	31'-6"	29'-10"	27'-10"	34'-11"	33'-0"	30'-10"
		30	15	26'-6"	25'-0"	23'-3"	30'-2"	28'-6"	26'-6"	33'-5"	31'-7"	29'-4"
		40	10	25'-2"	24'-1"	22'-9"	28'-8"	27'-6"	26'-0"	31'-9"	30'-5"	28'-9"
		40	15	24'-9"	23'-5"	21'-10"	28'-3"	26'-8"	24'-11"	31'-3"	29'-7"	27'-7"
		50	10	23'-3"	22'-4"	21'-2"	26'-6"	25'-5"	24'-2"	29'-5"	28'-2"	26'-9"
	50	15	23'-3"	22'-2"	20'-9"	26'-6"	25'-3"	23'-8"	28'-7"	27'-8"	26'-2"	
	19.2" o.c.	Non-Snow 125%	20	10	28'-7"	27'-0"	25'-1"	32'-7"	30'-9"	28'-7"	36'-1"	34'-1"
20			15	27'-1"	25'-5"	23'-6"	30'-10"	29'-0"	26'-9"	34'-2"	32'-1"	29'-8"
20			20	25'-10"	24'-2"	22'-3"	29'-5"	27'-7"	25'-4"	32'-7"	30'-6"	28'-1"
Snow 115%		25	10	27'-2"	25'-8"	23'-11"	30'-11"	29'-3"	27'-3"	34'-3"	32'-5"	30'-2"
		25	15	25'-11"	24'-5"	22'-7"	29'-6"	27'-10"	25'-9"	32'-8"	30'-9"	28'-6"
		30	10	25'-11"	24'-7"	22'-11"	29'-7"	28'-0"	26'-2"	32'-9"	31'-0"	29'-0"
		30	15	24'-11"	23'-6"	21'-10"	28'-4"	26'-9"	24'-10"	31'-5"	29'-8"	27'-6"
		40	10	23'-7"	22'-8"	21'-5"	26'-11"	25'-10"	24'-5"	29'-10"	28'-7"	27'-0"
		40	15	23'-3"	22'-0"	20'-6"	26'-6"	25'-1"	23'-5"	28'-1"	27'-0"	25'-7"
		50	10	21'-10"	21'-0"	19'-11"	24'-11"	23'-11"	22'-8"	25'-10"	25'-3"	24'-5"
50		15	21'-10"	20'-10"	19'-6"	23'-9"	23'-0"	21'-11"	23'-9"	23'-0"	21'-11"	
24" o.c.		Non-Snow 125%	20	10	26'-6"	25'-0"	23'-3"	30'-2"	28'-6"	26'-6"	33'-5"	31'-7"
	20		15	25'-1"	23'-7"	21'-9"	28'-7"	26'-10"	24'-10"	31'-8"	29'-9"	27'-6"
	20		20	23'-11"	22'-5"	20'-7"	27'-3"	25'-6"	23'-6"	30'-2"	28'-3"	26'-0"
	Snow 115%	25	10	25'-2"	23'-9"	22'-2"	28'-8"	27'-1"	25'-3"	31'-9"	30'-0"	28'-0"
		25	15	24'-0"	22'-7"	20'-11"	27'-4"	25'-9"	23'-10"	30'-3"	28'-6"	26'-5"
		30	10	24'-0"	22'-9"	21'-3"	27'-5"	25'-11"	24'-3"	30'-4"	28'-9"	26'-10"
		30	15	23'-0"	21'-9"	20'-2"	26'-3"	24'-9"	23'-0"	27'-4"	26'-1"	24'-5"
		40	10	21'-10"	21'-0"	19'-10"	24'-9"	23'-11"	22'-7"	24'-9"	24'-1"	23'-1"
		40	15	21'-6"	20'-4"	19'-0"	22'-5"	21'-6"	20'-5"	22'-5"	21'-6"	20'-5"
		50	10	20'-2"	19'-5"	18'-5"	20'-8"	20'-2"	19'-6"	20'-8"	20'-2"	19'-6"
	50	15	19'-0"	18'-4"	17'-6"	19'-0"	18'-4"	17'-6"	19'-0"	18'-4"	17'-6"	
	32" o.c.	Non-Snow 125%	20	10	24'-0"	22'-8"	21'-0"	27'-4"	25'-10"	24'-0"	30'-3"	28'-7"
20			15	22'-8"	21'-4"	19'-8"	25'-10"	24'-4"	22'-6"	28'-6"	26'-10"	24'-9"
20			20	21'-8"	20'-3"	18'-8"	24'-8"	23'-1"	21'-1"	24'-10"	23'-2"	21'-1"
Snow 115%		25	10	22'-9"	21'-6"	20'-1"	25'-11"	24'-7"	22'-10"	26'-5"	25'-4"	24'-0"
		25	15	21'-8"	20'-5"	18'-11"	23'-0"	21'-9"	20'-3"	23'-0"	21'-9"	20'-3"
		30	10	21'-9"	20'-7"	19'-3"	23'-2"	22'-4"	21'-3"	23'-2"	22'-4"	21'-3"
		30	15	20'-5"	19'-6"	18'-3"	20'-5"	19'-6"	18'-3"	20'-5"	19'-6"	18'-3"
		40	10	18'-6"	18'-0"	17'-3"	18'-6"	18'-0"	17'-3"	18'-6"	18'-0"	17'-3"
		40	15	16'-9"	16'-1"	15'-3"	16'-9"	16'-1"	15'-3"	16'-9"	16'-1"	15'-3"
		50	10	15'-5"	15'-0"	14'-6"	15'-5"	15'-0"	14'-6"	15'-5"	15'-0"	14'-6"
50		15	14'-2"	13'-8"	13'-1"	14'-2"	13'-8"	13'-1"	14'-2"	13'-8"	13'-1"	

- Tables are intended to be used for preliminary sizing of roof members only and not for final sizing. Tables are based on a uniformly loaded roof due to roof live or snow loads and dead load. Wind loading, unbalanced snow loading, snow drifting, sliding and surcharges, and roof-top mechanical units are NOT considered in the tables. The determination of such roof design loads is the responsibility of the project's design professional of record.
- Table values are limited by shear, moment, total load deflection equal to L/180 and live load deflection equal to L/240. Check the local building code for other deflection limits that may apply.
- Table values represent the most restrictive of simple or multiple span applications.
- Table values assume minimum bearing lengths without web stiffeners for joist depths of 16 inches and less. 18 and 20 inch joists require web stiffeners.
- This table was designed to apply to a broad range of applications. It may be possible to exceed the limitations of this table by analyzing a specific application with the BC CALC® software.
- Slope roof joists at least 1/4" over 12" to minimize ponding.
- Allowable spans and loads shall be adjusted and checked for wind load as required by local building code.

Maximum clear span in feet and inches, based on horizontal spans.

				BCI® 90 2.0 Series 3½" Flange Width															
				11⅞" BCI® 90 2.0			14" BCI® 90 2.0			16" BCI® 90 2.0			18" BCI® 90 2.0			20" BCI® 90 2.0			
				4/12 or Less	4/12 to 8/12	8/12 to 12/12	4/12 or Less	4/12 to 8/12	8/12 to 12/12	4/12 or Less	4/12 to 8/12	8/12 to 12/12	4/12 or Less	4/12 to 8/12	8/12 to 12/12	4/12 or Less	4/12 to 8/12	8/12 to 12/12	
o.c.		Live Load [psf]	Dead Load [psf]																
						115% and 125% Load Duration													
16"	Non-Snow 125%	20	10	34'-10"	32'-10"	30'-6"	39'-6"	37'-4"	34'-7"	43'-9"	41'-4"	38'-4"	47'-10"	45'-2"	41'-11"	50'-0"	48'-10"	45'-4"	
		20	15	33'-0"	31'-0"	28'-7"	37'-5"	35'-2"	32'-6"	41'-5"	38'-11"	36'-0"	45'-4"	42'-7"	39'-4"	49'-0"	46'-1"	42'-6"	
		20	20	31'-6"	29'-6"	27'-1"	35'-8"	33'-5"	30'-9"	39'-7"	37'-0"	34'-1"	43'-3"	40'-6"	37'-3"	46'-9"	43'-10"	40'-3"	
	Snow 115%	25	10	33'-1"	31'-3"	29'-1"	37'-6"	35'-6"	33'-1"	41'-7"	39'-4"	36'-7"	45'-5"	42'-11"	40'-0"	49'-2"	46'-6"	43'-3"	
		25	15	31'-6"	29'-8"	27'-6"	35'-9"	33'-8"	31'-3"	39'-8"	37'-4"	34'-7"	43'-4"	40'-10"	37'-9"	46'-10"	44'-2"	40'-11"	
		30	10	31'-7"	29'-11"	27'-11"	35'-10"	34'-0"	31'-9"	39'-9"	37'-8"	35'-2"	43'-5"	41'-2"	38'-5"	47'-0"	44'-6"	41'-6"	
		30	15	30'-4"	28'-7"	26'-7"	34'-5"	32'-5"	30'-2"	38'-1"	35'-11"	33'-5"	41'-7"	39'-3"	36'-6"	45'-0"	42'-6"	39'-6"	
		40	10	28'-9"	27'-7"	26'-1"	32'-7"	31'-4"	29'-7"	36'-2"	34'-8"	32'-9"	39'-6"	37'-11"	35'-10"	42'-9"	41'-0"	38'-9"	
		40	15	28'-4"	26'-9"	25'-0"	32'-1"	30'-5"	28'-4"	35'-7"	33'-8"	31'-5"	38'-10"	36'-10"	34'-4"	42'-1"	39'-10"	37'-2"	
		50	10	26'-7"	25'-6"	24'-3"	30'-2"	29'-0"	27'-6"	33'-5"	32'-1"	30'-6"	36'-7"	35'-1"	33'-4"	39'-7"	38'-0"	36'-1"	
	50	15	26'-7"	25'-4"	23'-9"	30'-2"	28'-9"	26'-11"	33'-5"	31'-11"	29'-10"	36'-7"	34'-10"	32'-7"	39'-7"	37'-8"	35'-3"		
	19.2"	Non-Snow 125%	20	10	32'-9"	30'-11"	28'-8"	37'-2"	35'-0"	32'-6"	41'-2"	38'-10"	36'-0"	44'-11"	42'-5"	39'-4"	48'-8"	45'-11"	42'-7"
			20	15	31'-0"	29'-1"	26'-11"	35'-2"	33'-0"	30'-6"	38'-11"	36'-7"	33'-9"	42'-7"	40'-0"	36'-11"	46'-0"	43'-3"	39'-11"
			20	20	29'-6"	27'-8"	25'-5"	33'-6"	31'-5"	28'-11"	37'-2"	34'-9"	32'-0"	40'-7"	38'-0"	35'-0"	43'-11"	41'-2"	37'-10"
Snow 115%		25	10	31'-1"	29'-5"	27'-4"	35'-3"	33'-4"	31'-1"	39'-0"	36'-11"	34'-5"	42'-8"	40'-4"	37'-7"	46'-2"	43'-8"	40'-8"	
		25	15	29'-7"	27'-11"	25'-10"	33'-7"	31'-8"	29'-4"	37'-3"	35'-1"	32'-6"	40'-8"	38'-4"	35'-6"	44'-0"	41'-6"	38'-5"	
		30	10	29'-8"	28'-1"	26'-3"	33'-8"	31'-11"	29'-10"	37'-4"	35'-4"	33'-0"	40'-9"	38'-8"	36'-1"	44'-1"	41'-10"	39'-0"	
		30	15	28'-5"	26'-10"	24'-11"	32'-3"	30'-6"	28'-4"	35'-9"	33'-9"	31'-4"	39'-1"	36'-11"	34'-3"	42'-3"	39'-11"	37'-1"	
		40	10	27'-0"	25'-11"	24'-6"	30'-7"	29'-5"	27'-9"	33'-11"	32'-7"	30'-9"	37'-1"	35'-7"	33'-7"	40'-1"	38'-6"	36'-5"	
		40	15	26'-7"	25'-2"	23'-5"	30'-2"	28'-7"	26'-7"	33'-5"	31'-7"	29'-6"	36'-6"	34'-7"	32'-3"	39'-6"	37'-5"	34'-11"	
		50	10	24'-11"	24'-0"	22'-9"	28'-4"	27'-2"	25'-10"	31'-5"	30'-2"	28'-8"	34'-4"	32'-11"	31'-4"	37'-1"	35'-8"	33'-10"	
50		15	24'-11"	23'-10"	22'-3"	28'-4"	27'-0"	25'-3"	29'-8"	28'-8"	27'-5"	34'-4"	32'-8"	30'-7"	37'-1"	35'-5"	33'-1"		
24"		Non-Snow 125%	20	10	30'-4"	28'-7"	26'-7"	34'-5"	32'-5"	30'-2"	38'-1"	35'-11"	33'-5"	41'-7"	39'-3"	36'-6"	45'-0"	42'-6"	39'-6"
			20	15	28'-8"	26'-11"	24'-11"	32'-6"	30'-7"	28'-3"	36'-1"	33'-11"	31'-4"	39'-5"	37'-0"	34'-2"	42'-8"	40'-1"	37'-0"
			20	20	27'-4"	25'-7"	23'-7"	31'-0"	29'-1"	26'-9"	34'-4"	32'-2"	29'-8"	37'-7"	35'-2"	32'-5"	40'-8"	38'-1"	35'-1"
	Snow 115%	25	10	28'-9"	27'-2"	25'-4"	32'-7"	30'-10"	28'-9"	36'-2"	34'-2"	31'-10"	39'-6"	37'-4"	34'-10"	42'-9"	40'-5"	37'-8"	
		25	15	27'-5"	25'-10"	23'-11"	31'-1"	29'-4"	27'-2"	34'-5"	32'-6"	30'-1"	37'-8"	35'-6"	32'-11"	40'-9"	38'-5"	35'-7"	
		30	10	27'-6"	26'-0"	24'-4"	31'-2"	29'-7"	27'-7"	34'-6"	32'-9"	30'-7"	37'-9"	35'-9"	33'-5"	40'-10"	38'-9"	36'-2"	
		30	15	26'-4"	24'-10"	23'-1"	29'-10"	28'-2"	26'-3"	33'-1"	31'-3"	29'-1"	36'-2"	34'-2"	31'-9"	39'-2"	37'-0"	34'-4"	
		40	10	24'-11"	24'-0"	22'-8"	28'-4"	27'-2"	25'-9"	30'-11"	30'-0"	28'-6"	34'-4"	32'-11"	31'-2"	37'-1"	35'-8"	33'-8"	
		40	15	24'-7"	23'-3"	21'-9"	27'-9"	26'-5"	24'-8"	28'-0"	26'-11"	25'-6"	33'-9"	32'-0"	29'-10"	35'-2"	33'-10"	32'-1"	
		50	10	23'-1"	22'-2"	21'-1"	25'-7"	24'-11"	23'-11"	25'-9"	25'-2"	24'-4"	31'-3"	30'-6"	29'-0"	32'-5"	31'-8"	30'-7"	
	50	15	23'-1"	22'-0"	20'-7"	23'-6"	22'-9"	21'-8"	23'-8"	22'-11"	21'-10"	28'-9"	27'-10"	26'-7"	29'-10"	28'-10"	27'-6"		
	32"	Non-Snow 125%	20	10	27'-5"	25'-11"	24'-1"	31'-1"	29'-5"	27'-4"	34'-6"	32'-7"	30'-3"	37'-8"	35'-7"	33'-1"	40'-9"	38'-6"	35'-9"
			20	15	25'-11"	24'-5"	22'-6"	29'-5"	27'-8"	25'-7"	32'-7"	30'-8"	28'-4"	35'-8"	33'-6"	31'-0"	38'-7"	36'-3"	33'-6"
			20	20	24'-9"	23'-2"	21'-4"	28'-1"	26'-4"	24'-3"	31'-0"	28'-11"	26'-4"	34'-0"	31'-10"	29'-4"	36'-9"	34'-6"	31'-9"
Snow 115%		25	10	26'-0"	24'-7"	22'-11"	29'-6"	27'-11"	26'-1"	32'-8"	30'-11"	28'-10"	35'-9"	33'-10"	31'-6"	38'-8"	36'-7"	34'-2"	
		25	15	24'-9"	23'-4"	21'-8"	28'-1"	26'-6"	24'-7"	28'-8"	27'-2"	25'-4"	34'-1"	32'-1"	29'-9"	36'-1"	34'-3"	31'-10"	
		30	10	24'-10"	23'-7"	22'-0"	28'-2"	26'-9"	25'-0"	28'-11"	27'-10"	26'-6"	34'-2"	32'-5"	30'-3"	36'-4"	35'-0"	32'-9"	
		30	15	23'-9"	22'-6"	20'-11"	25'-4"	24'-2"	22'-8"	25'-6"	24'-4"	22'-10"	31'-0"	29'-7"	27'-8"	32'-1"	30'-8"	28'-8"	
		40	10	22'-7"	21'-8"	20'-6"	22'-11"	22'-3"	21'-5"	23'-1"	22'-5"	21'-7"	28'-1"	27'-3"	26'-2"	29'-1"	28'-3"	27'-2"	
		40	15	20'-7"	19'-10"	18'-9"	20'-9"	19'-11"	18'-11"	20'-11"	20'-1"	19'-1"	25'-5"	24'-5"	23'-2"	26'-4"	25'-4"	24'-0"	
		50	10	19'-0"	18'-6"	17'-11"	19'-1"	18'-8"	18'-0"	19'-3"	18'-10"	18'-2"	23'-5"	22'-10"	22'-1"	24'-3"	23'-8"	22'-10"	
50		15	17'-5"	16'-10"	16'-1"	17'-7"	17'-0"	16'-3"	17'-8"	17'-1"	16'-4"	21'-6"	20'-9"	19'-10"	22'-3"	21'-7"	20'-7"		



## Allowable Uniform Roof Load (in pounds per lineal foot [PLF])

### 115% and 125% Load Duration

Use of these tables should be limited to roof slopes of 3½" per foot or less.  
For steeper slopes, see pages 24-27.

BCI <sup>®</sup> 5000 1.7 Series 2" Flange Width												
Span Length	9½" BCI <sup>®</sup> 5000 1.7			11⅞" BCI <sup>®</sup> 5000 1.7			14" BCI <sup>®</sup> 5000 1.7			16" BCI <sup>®</sup> 5000 1.7		
	Total Load		Deflect.	Total Load		Deflect.	Total Load		Deflect.	Total Load		Deflect.
	Snow (115%)	Non-Snow (125%)	L/240	Snow (115%)	Non-Snow (125%)	L/240	Snow (115%)	Non-Snow (125%)	L/240	Snow (115%)	Non-Snow (125%)	L/240
	6	315	343	-	338	367	-	353	383	-	356	387
7	270	294	-	289	315	-	302	329	-	305	332	-
8	236	257	-	253	275	-	264	287	-	267	290	-
9	210	228	-	225	245	-	235	255	-	237	258	-
10	189	205	-	202	220	-	211	230	-	214	232	-
11	172	187	-	184	200	-	192	209	-	194	211	-
12	154	167	-	169	183	-	176	191	-	178	193	-
13	131	142	-	156	169	-	162	177	-	164	179	-
14	113	123	110	144	157	-	151	164	-	152	166	-
15	98	107	90	126	137	-	141	153	-	142	155	-
16	86	94	75	110	120	-	131	142	-	133	145	-
17	76	82	63	98	106	-	116	126	-	125	136	-
18	68	70	53	87	95	-	103	112	-	118	128	-
19	59	59	45	78	85	74	93	101	-	106	115	-
20	51	51	39	71	77	64	84	91	-	96	104	-
21				64	70	55	76	83	-	87	94	-
22				58	63	48	69	75	-	79	86	-
23				53	55	42	63	69	62	72	78	-
24							58	63	55	66	72	-
25							53	58	49	61	66	-
26										56	61	-
27										52	57	-
28												

- Tables are intended to be used for preliminary sizing of roof members only and not for final sizing. Tables are based on a uniformly loaded roof due to roof live or snow loads and dead load. Wind loading, unbalanced snow loading, snow drifting, sliding and surcharges, and roof-top mechanical units are NOT considered in the tables. The determination of such roof design loads is the responsibility of the project's design professional of record.

- Total Load values are limited by shear, moment, or deflection equal to L/180.

- Deflection values (Deflect.) are limited by live load deflection equal to L/240. Check the local building code for other deflection limits that may apply.

- Both the Total Load and Deflection columns must be checked. Where a Deflection value is not shown, the Total Load value will control.

- Table values apply to either simple or multiple span joists. Span is measured center to center of the minimum required bearing length. Analyze multiple span joists with the BC CALC<sup>®</sup> software if the length of any span is less than half the length of an adjacent span.

- Slope roof joists at least ¼ inch over 12 inches to minimize ponding.

- Table values assume minimum bearing lengths without web stiffeners for joist depths of 16 inches and less. 18 and 20 inch joists require web stiffeners.

- This table was designed to apply to a broad range of applications. It may be possible to exceed the limitations of this table by analyzing a specific application with the BC CALC<sup>®</sup> software.

- Allowable spans and loads shall be adjusted and checked for wind load as required by local building code.

## Allowable Uniform Roof Load (in pounds per lineal foot [PLF])

### 115% and 125% Load Duration

Use of these tables should be limited to roof slopes of 3½" per foot or less.  
For steeper slopes, see pages 24-27.

Span Length	BCI® 6000 1.8 Series 2 <sup>5</sup> / <sub>16</sub> " Flange Width											
	9½" BCI® 6000 1.8			11⅞" BCI® 6000 1.8			14" BCI® 6000 1.8			16" BCI® 6000 1.8		
	Total Load		Deflect.	Total Load		Deflect.	Total Load		Deflect.	Total Load		Deflect.
	Snow (115%)	Non-Snow (125%)	L/240	Snow (115%)	Non-Snow (125%)	L/240	Snow (115%)	Non-Snow (125%)	L/240	Snow (115%)	Non-Snow (125%)	L/240
6	360	392	-	375	408	-	390	424	-	398	432	-
7	309	336	-	322	350	-	334	364	-	341	371	-
8	270	294	-	281	306	-	293	318	-	298	324	-
9	240	261	-	250	272	-	260	283	-	265	288	-
10	216	235	-	225	245	-	234	254	-	238	259	-
11	196	213	-	204	222	-	213	231	-	217	236	-
12	180	196	-	187	204	-	195	212	-	199	216	-
13	166	180	159	173	188	-	180	196	-	183	199	-
14	145	158	129	161	175	-	167	182	-	170	185	-
15	126	137	106	150	163	-	156	169	-	159	173	-
16	111	115	88	140	153	-	146	159	-	149	162	-
17	97	97	74	126	137	122	137	149	-	140	152	-
18	82	82	63	112	122	103	130	141	-	132	144	-
19	70	70	53	101	110	89	120	130	-	125	136	-
20	60	60	46	91	99	76	108	117	-	119	129	-
21	52	52	40	83	87	66	98	107	97	112	122	-
22				75	76	58	89	97	85	102	111	-
23				67	67	51	82	89	75	93	101	-
24				59	59	45	75	81	66	86	93	-
25				52	52	40	69	75	58	79	86	78
26							64	68	52	73	79	70
27							59	61	47	67	73	63
28							55	55	42	63	68	56



## Allowable Uniform Roof Load (in pounds per lineal foot [PLF])

### 115% and 125% Load Duration

Use of these tables should be limited to roof slopes of 3½" per foot or less.  
For steeper slopes, see pages 24-27.

BCI <sup>®</sup> 6500 1.8 Series 2 <sup>9</sup> / <sub>16</sub> " Flange Width												
Span Length	9½" BCI <sup>®</sup> 6500 1.8			11 <sup>7</sup> / <sub>8</sub> " BCI <sup>®</sup> 6500 1.8			14" BCI <sup>®</sup> 6500 1.8			16" BCI <sup>®</sup> 6500 1.8		
	Total Load		Deflect.	Total Load		Deflect.	Total Load		Deflect.	Total Load		Deflect.
	Snow (115%)	Non-Snow (125%)	L/240	Snow (115%)	Non-Snow (125%)	L/240	Snow (115%)	Non-Snow (125%)	L/240	Snow (115%)	Non-Snow (125%)	L/240
	6	360	392	-	375	408	-	390	424	-	398	432
7	309	336	-	322	350	-	334	364	-	341	371	-
8	270	294	-	281	306	-	293	318	-	298	324	-
9	240	261	-	250	272	-	260	283	-	265	288	-
10	216	235	-	225	245	-	234	254	-	238	259	-
11	196	213	-	204	222	-	213	231	-	217	236	-
12	180	196	-	187	204	-	195	212	-	199	216	-
13	166	180	-	173	188	-	180	196	-	183	199	-
14	154	168	141	161	175	-	167	182	-	170	185	-
15	140	152	116	150	163	-	156	169	-	159	173	-
16	123	126	97	140	153	-	146	159	-	149	162	-
17	106	106	81	132	144	-	137	149	-	140	152	-
18	90	90	69	125	135	114	130	141	-	132	144	-
19	77	77	59	112	122	97	123	134	-	125	136	-
20	66	66	51	101	110	84	117	127	-	119	129	-
21	57	57	44	91	95	73	108	118	106	113	123	-
22	50	50	38	83	83	64	99	107	92	108	118	-
23				73	73	56	90	98	81	103	112	-
24				64	64	49	83	90	72	95	103	-
25				57	57	44	76	83	64	87	95	85
26				51	51	39	71	74	57	81	88	76
27							65	67	51	75	81	68
28							60	60	46	69	76	61
29							54	54	41	65	70	55
30										60	66	50
31										57	60	45
32										53	54	41
33										50	50	38
34												
35												

- Tables are intended to be used for preliminary sizing of roof members only and not for final sizing. Tables are based on a uniformly loaded roof due to roof live or snow loads and dead load. Wind loading, unbalanced snow loading, snow drifting, sliding and surcharges, and roof-top mechanical units are NOT considered in the tables. The determination of such roof design loads is the responsibility of the project's design professional of record.
- Total Load values are limited by shear, moment, or deflection equal to L/180.
- Deflection values (Deflect.) are limited by live load deflection equal to L/240. Check the local building code for other deflection limits that may apply.
- Both the Total Load and Deflection columns must be checked. Where a Deflection value is not shown, the Total Load value will control.

- Table values apply to either simple or multiple span joists. Span is measured center to center of the minimum required bearing length. Analyze multiple span joists with the BC CALC<sup>®</sup> software if the length of any span is less than half the length of an adjacent span.
- Slope roof joists at least ¼ inch over 12 inches to minimize ponding.
- Table values assume minimum bearing lengths without web stiffeners for joist depths of 16 inches and less. 18 and 20 inch joists require web stiffeners.
- This table was designed to apply to a broad range of applications. It may be possible to exceed the limitations of this table by analyzing a specific application with the BC CALC<sup>®</sup> software.
- Allowable spans and loads shall be adjusted and checked for wind load as required by local building code.



## Allowable Uniform Roof Load (in pounds per lineal foot [PLF])

### 115% and 125% Load Duration

Use of these tables should be limited to roof slopes of 3½" per foot or less.  
For steeper slopes, see pages 24-27.

Span Length	BCI® 60 2.0 Series 2 <sup>5</sup> / <sub>16</sub> " Flange Width								
	11 <sup>7</sup> / <sub>8</sub> " BCI® 60 2.0			14" BCI® 60 2.0			16" BCI® 60 2.0		
	Total Load		Deflect.	Total Load		Deflect.	Total Load		Deflect.
	Snow (115%)	Non-Snow (125%)	L/240	Snow (115%)	Non-Snow (125%)	L/240	Snow (115%)	Non-Snow (125%)	L/240
6	413	449	-	413	449	-	413	449	-
7	354	385	-	354	385	-	354	385	-
8	309	336	-	309	336	-	309	336	-
9	275	299	-	275	299	-	275	299	-
10	247	269	-	247	269	-	247	269	-
11	225	245	-	225	245	-	225	245	-
12	206	224	-	206	224	-	206	224	-
13	190	207	-	190	207	-	190	207	-
14	177	192	-	177	192	-	177	192	-
15	165	179	-	165	179	-	165	179	-
16	154	168	-	154	168	-	154	168	-
17	145	158	-	145	158	-	145	158	-
18	137	149	-	137	149	-	137	149	-
19	130	141	118	130	141	-	130	141	-
20	123	133	102	123	134	-	123	134	-
21	116	116	88	118	128	-	118	128	-
22	101	101	77	112	122	-	112	122	-
23	89	89	68	107	117	99	107	117	-
24	79	79	60	103	112	88	103	112	-
25	70	70	53	99	102	78	99	107	-
26	62	62	47	91	91	69	95	103	93
27	56	56	42	81	81	62	91	99	84
28	50	50	38	73	73	56	88	96	75
29				66	66	50	85	89	68
30				60	60	46	81	81	61
31				54	54	41	73	73	56
32							67	67	51
33							61	61	46
34							56	56	43
35							51	51	39



## Allowable Uniform Roof Load (in pounds per lineal foot [PLF])

### 115% and 125% Load Duration

Use of these tables should be limited to roof slopes of 3½" per foot or less.  
For steeper slopes, see pages 24-27.

Span Length	BCI® 90 2.0 Series 3½" Flange Width														
	11⅞" BCI® 90 2.0			14" BCI® 90 2.0			16" BCI® 90 2.0			18" BCI® 90 2.0			20" BCI® 90 2.0		
	Total Load		Deflect.	Total Load		Deflect.	Total Load		Deflect.	Total Load		Deflect.	Total Load		Deflect.
	Snow (115%)	Non-Snow (125%)	L/240	Snow (115%)	Non-Snow (125%)	L/240	Snow (115%)	Non-Snow (125%)	L/240	Snow (115%)	Non-Snow (125%)	L/240	Snow (115%)	Non-Snow (125%)	L/240
6	507	551	-	510	555	-	514	559	-	623	677	-	646	702	-
7	434	472	-	437	476	-	441	479	-	534	581	-	553	602	-
8	380	413	-	383	416	-	385	419	-	467	508	-	484	526	-
9	338	367	-	340	370	-	343	372	-	415	451	-	430	468	-
10	304	330	-	306	333	-	308	335	-	374	406	-	387	421	-
11	276	300	-	278	302	-	280	305	-	340	369	-	352	383	-
12	253	275	-	255	277	-	257	279	-	311	338	-	323	351	-
13	234	254	-	235	256	-	237	258	-	287	312	-	298	324	-
14	217	236	-	218	238	-	220	239	-	267	290	-	276	301	-
15	202	220	-	204	222	-	205	223	-	249	271	-	258	280	-
16	190	206	-	191	208	-	192	209	-	233	254	-	242	263	-
17	178	194	-	180	196	-	181	197	-	220	239	-	228	247	-
18	169	183	-	170	185	-	171	186	-	207	225	-	215	234	-
19	160	174	-	161	175	-	162	176	-	196	214	-	204	221	-
20	152	165	148	153	166	-	154	167	-	187	203	-	193	210	-
21	144	157	129	145	158	-	147	159	-	178	193	-	184	200	-
22	138	148	113	139	151	-	140	152	-	170	184	-	176	191	-
23	130	130	100	133	144	-	134	145	-	162	176	-	168	183	-
24	115	115	88	127	138	126	128	139	-	155	169	-	161	175	-
25	103	103	78	122	133	112	123	134	-	149	162	-	155	168	-
26	92	92	70	117	128	100	118	129	-	143	156	-	149	162	-
27	82	82	63	113	118	90	114	124	-	138	150	-	143	156	-
28	74	74	56	106	106	81	110	119	109	133	145	-	138	150	-
29	67	67	51	96	96	73	106	115	98	129	140	127	133	145	-
30	60	60	46	87	87	67	102	111	89	124	135	115	129	140	-
31	55	55	42	79	79	60	99	106	81	120	131	105	125	135	-
32	50	50	38	72	72	55	96	97	74	116	125	96	121	131	120
33				66	66	50	89	89	68	113	114	88	117	127	110
34				60	60	46	81	81	62	105	105	80	114	123	101

- Tables are intended to be used for preliminary sizing of roof members only and not for final sizing. Tables are based on a uniformly loaded roof due to roof live or snow loads and dead load. Wind loading, unbalanced snow loading, snow drifting, sliding and surcharges, and roof-top mechanical units are NOT considered in the tables. The determination of such roof design loads is the responsibility of the project's design professional of record.
- Total Load values are limited by shear, moment, or deflection equal to L/180.
- Deflection values (Deflect.) are limited by live load deflection equal to L/240. Check the local building code for other deflection limits that may apply.
- Both the Total Load and Deflection columns must be checked. Where a Deflection value is not shown, the Total Load value will control.
- Table values apply to either simple or multiple span joists. Span is measured center

to center of the minimum required bearing length. Analyze multiple span joists with the BC CALC® software if the length of any span is less than half the length of an adjacent span.

- Slope roof joists at least ¼ inch over 12 inches to minimize ponding.
- Table values assume minimum bearing lengths without web stiffeners for joist depths of 16 inches and less. 18 and 20 inch joists require web stiffeners.
- This table was designed to apply to a broad range of applications. It may be possible to exceed the limitations of this table by analyzing a specific application with the BC CALC® software.
- Allowable spans and loads shall be adjusted and checked for wind load as required by local building code.

BCI® Joist Series	Depth [inches]	Weight [plf]	Moment [ft-lbs]	EI x 10 <sup>6</sup> [lb-in <sup>2</sup> ]	K x 10 <sup>6</sup> [lbs]	Shear [lbs]	End Reaction [lbs]				Intermediate Reaction [lbs]			
							1½" Bearing <sup>(1)</sup>		3½" Bearing		3½" Bearing		5¼" Bearing	
							No WS <sup>(2)</sup>	WS <sup>(3)</sup>	No WS <sup>(2)</sup>	WS <sup>(3)</sup>	No WS <sup>(2)</sup>	WS <sup>(3)</sup>	No WS <sup>(2)</sup>	WS <sup>(3)</sup>
5000 1.7	9½	2.0	2460	160	5.0	1475	950	1125	1125	1275	2100	2350	2525	2750
	11⅞	2.3	3150	265	6.0	1625	950	1425	1425	1475	2250	2850	2525	3000
	14	2.5	3735	390	8.0	1825	950	1525	1475	1725	2350	3050	2525	3200
	16	2.7	4260	530	9.0	1975	950	1625	1500	1975	2400	3200	2525	3350
6000 1.8	9½	2.2	3165	190	5.0	1575	1175	1375	1375	1425	2400	2650	2700	2750
	11⅞	2.5	4060	320	6.0	1675	1175	1425	1425	1475	2500	2850	2900	3000
	14	2.7	4815	470	8.0	1925	1175	1525	1525	1725	2600	3150	2925	3200
	16	2.9	5495	635	9.0	2175	1175	1625	1550	1975	2650	3350	2950	3350
6500 1.8	9½	2.3	3505	210	5.0	1575	1175	1375	1375	1425	2400	2650	2700	2750
	11⅞	2.6	4495	350	7.0	1675	1175	1425	1425	1475	2500	2850	2900	3000
	14	3.0	5330	515	8.0	1925	1175	1525	1525	1725	2600	3150	2925	3200
	16	3.2	6085	695	9.0	2175	1175	1625	1550	1975	2650	3350	2950	3350
60 2.0	11⅞	2.9	6235	430	7.0	1675	1175	1425	1425	1475	2750	2850	3200	3250
	14	3.1	7440	635	8.0	1925	1175	1525	1525	1725	2750	3450	3200	3650
	16	3.3	8520	860	9.0	2175	1175	1625	1550	1975	2750	3650	3200	3750
90 2.0	11⅞	3.9	9550	645	7.0	2150	1425	1850	1800	1950	3375	3700	4000	4300
	14	4.1	11390	940	8.0	2350	1450	1950	1850	2150	3400	3850	4100	4450
	16	4.4	13050	1275	9.0	2550	1475	2150	1900	2350	3425	4000	4200	4650
	18	4.6	14690	1660	10.0	2750	N/A <sup>(3)</sup>	2300	N/A <sup>(3)</sup>	2550	N/A <sup>(3)</sup>	4150	N/A <sup>(3)</sup>	4750
	20	4.8	16310	2100	11.0	2850	N/A <sup>(3)</sup>	2500	N/A <sup>(3)</sup>	2650	N/A <sup>(3)</sup>	4300	N/A <sup>(3)</sup>	4850

**NOTES:**

- (1) No web stiffeners required.
- (2) Web stiffeners required.
- (3) Not applicable, web stiffeners required.
- Moment, shear and reactions values based upon a load duration of 100% and may be adjusted for other load durations.
- Design values listed are applicable for Allowable Stress Design (ASD).
- No additional repetitive member increased allowed.

$$\Delta = \frac{5wl^4}{384EI} + \frac{wl^2}{K}$$

- Δ = deflection [in]
- w = uniform load [lb/in]
- l = clear span [in]
- EI = bending stiffness [lb-in<sup>2</sup>]
- K = shear deformation coefficient [lb]

**BUILDING CODE EVALUATION REPORT**

- ICC ESR 1336 (IBC, IRC)

## BCI® Closest Allowable Nail Spacing

Nailing Perpendicular to Glue Lines (Wide Face)

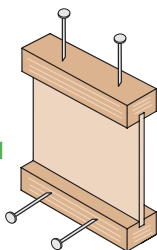

Nailing Parallel to Glue Lines (Narrow Face)

Nail Size	All BCI® Joists			
	Nailing Perpendicular to Glue Line (Wide Face)		Nailing Parallel to Glue Line (Narrow Face)	
	O.C. Spacing [inches]	End of Joist [inches]	O.C. Spacing [inches]	End of Joist [inches]
8d Box	2	1½	4	1½
8d Common	2	1½	4	3
10d & 12d Box	2	1½	4	3
16d Box	2	1½	4	3
10d & 12d Common	3	2	6	4
16d Sinker	3	2	6	4
16d Common	3	2	6	4

- If more than one row of nails is used, the rows must be offset at least ½ inch.
- Simpson Strong-Tie A35 connectors may be attached to the side of BCI® 60 & 90 joist flanges only. Use nails as specified by Simpson Strong-Tie; do not attach connectors on both sides of a flange at the same location.

**BCI® Diaphragm Table <sup>(1)</sup>**

BCI® Series	Diaphragm Capacity <sup>(2)(3)</sup> [lb/ft]	
	Unblocked	Blocked
5000	As permitted for 2x framing in building code	320 lb/ft for 6" o.c. nailing @ panel edges 425 lb/ft for 4" o.c. nailing, staggered, @ panel edges
6000, 6500	As permitted for 3x framing in building code	360 lb/ft for 6" o.c. nailing @ panel edges 480 lb/ft for 4" o.c. nailing, staggered @ panel edges
60, 90	As permitted for 3x framing in building code	As permitted for 3x framing in building code with nail spacing no closer than 3" o.c.

**NOTES:**

- (1) See table 6 of ICC ESR 1336.
- (2) BCI® joists may be substituted for solid sawn framing in horizontal wood diaphragms as shown in Table 2306.3.1 of the IBC.
- (3) Limits controlled by BCI® closest allowable nail spacing limits.

## Boise Cascade Rimboard Product Profiles - Western Commercial

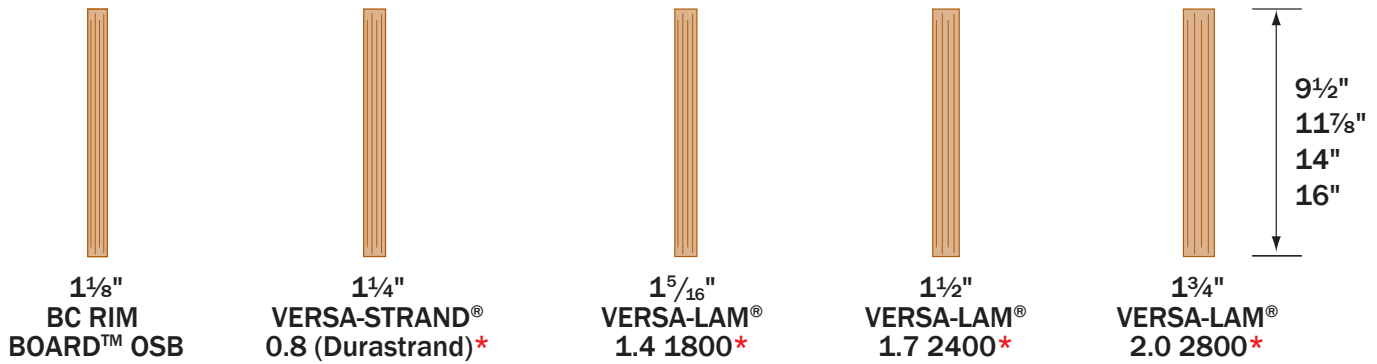

\*18 inch and 20 inch deep rimboard are special order products, contact local supplier or Boise Cascade EWP representative for product availability.

**F07** **Perpendicular**  
See chart for vertical load capacity.

Min. 8d nails @ 6" o.c. per IRC.  
Connection per design professional of record's specification for shear transfer.

**F07A** **Parallel**  
See chart for vertical load capacity.

Min. 8d nails @ 6" o.c. per IRC.  
Connection per design professional of record's specification for shear transfer.

**F56**

1/2" dia through bolts (ASTM A307 Grades A&B, SAE J429 Grades 1 or 2, or higher) with washers and nuts or 1/2" dia lag screws (full penetration)  
350 lb capacity for 1 1/8" & thicker rim,  
300 lb capacity for 1" rim, per fastener

Treated Ledger - Use only fasteners that are approved for use with corresponding wood treatment.

Boise Cascade Rimboard

Design of moisture control by others (only structural components shown above)

*For information regarding connection of exterior decks to interior floor systems per the 2009 IRC, section 502.2.2.3, contact Boise Cascade EWP Engineering.*

## Boise Cascade Rimboard Properties

Product	Type	Vertical Load Capacity				Maximum Floor Diaphragm Lateral Capacity [lb/ft]	Specific Gravity Equivalency for Lateral Fastener Design	Allowable Design Values			
		Uniform [plf]		Point [lb]				Flexural Stress [lb/in <sup>2</sup> ]	Modulus of Elasticity [lb/in <sup>2</sup> ]	Horizontal Shear [lb/in <sup>2</sup> ]	Compression Perpendicular to Grain [lb/in <sup>2</sup> ]
		16" Depth & Less	18" & 20" Depth	16" Depth & Less	18" & 20" Depth						
1 1/8" BC RIM BOARD® OSB <sup>(2)</sup>	OSB	4850	3200	3500	3500	200	0.5	Limited span capabilities, see note 2			
1 1/4" VERSA-STRAND® 0.8E <sup>(3)</sup> (Durastrand)	OSB	5700	3500	5900	5500	240 w/ 8d nails @ 6" o.c. 330 w/ 8d nails @ 4" o.c.	— <sup>(3)</sup>	1130	800,000	355	1415
1 5/16" VERSA-LAM® 1.4 1800 <sup>(1)</sup>	LVL	6000	5450	4450	4450	Permitted per building code for all nominal 2" thick framing blocked and unblocked diaphragms (4" nail spacing & greater)	0.5	1800	1,400,000	225	525
1 1/2" VERSA-LAM® 1.7 2400 <sup>(1)</sup>	LVL	4250	3700	3700	3500	Permitted per building code for all nominal 2" thick framing blocked and unblocked diaphragms (4" nail spacing & greater)	0.5	2400	1,700,000	285	750
1 3/4" VERSA-LAM® 2.0 2800 <sup>(1)</sup>	LVL	5700	4300	4300	3900	Permitted per building code for all nominal 2" thick framing blocked and unblocked diaphragms (4" nail spacing & greater)	0.5	2800	2,000,000	285	750

Product	Closest Allowable Nail Spacing - Narrow Face [in]					
	8d Box	8d Common	10d & 12d Box	16d Box	10d, 12d Common & 16d Sinker	16d Common
1 1/8" BC RIM BOARD® OSB <sup>(2)</sup>	3	3	See note 2 for nailing information			
1 1/4" VERSA-STRAND® 0.8E <sup>(3)</sup>	4	4	4	4	4	6
1 5/16" & 1 1/2" VERSA-LAM® <sup>(1)</sup>	3	3	3	3	4	6
1 3/4" VERSA-LAM®	2	3	3	3	4	6

### Notes

- Per ICC ESR-1040.
  - See Performance Rated Rim Boards, APA EWS #W345J for further product information.
  - See ICC ESR-1053 for further product information.
- Not all products and depths may be available, check with Boise Cascade representative for product availability.

## An Introduction to VERSA-LAM® Products



When you specify VERSA-LAM® laminated veneer headers/beams, you are building quality into your design. They are excellent as floor and roof framing supports or as headers for doors, windows and garage doors and columns.

Because they have no camber, VERSA-LAM® LVL products provide flatter, quieter floors, and consequently, the builder can expect happier customers with significantly fewer call backs.

## VERSA-LAM® Beam Architectural Specifications

**Scope:** This work includes the complete furnishing and installation of all VERSA-LAM® beams as shown on the drawings, herein specified and necessary to complete the work.

**Materials:** Douglas Fir-Larch veneers, laminated in a press with all grain parallel with the length of the member. Glues used in lamination are phenol formaldehyde and isocyanate exterior-type adhesives which comply with ASTM D2559.

**Design:** VERSA-LAM® beams shall be sized and detailed to fit the dimensions and loads indicated on the plans. All designs shall be in accordance with allowable values developed in accordance with ASTM D5456 and listed in the governing code evaluation service's report and

section properties based upon standard engineering principles. Verification of design of the VERSA-LAM® beams by complete calculations shall be available upon request.

**Drawings:** Additional drawings showing layout and detail necessary for determining fit and placement in the buildings are (are not) to be provided by the supplier.

**Fabrication:** VERSA-LAM® beams shall be manufactured in a plant evaluated for fabrication by the governing code evaluation service and under the supervision of a third-party inspection agency listed by the corresponding evaluation service.

**Storage and Installation:** VERSA-LAM® beams, if stored prior to erection, shall be stored on stickers spaced a maximum of 15 ft. apart. Beams shall be stored on a dry, level surface and protected from the weather. They shall be handled with care so they are not damaged.

VERSA-LAM® beams are to be installed in accordance with the plans and Boise Cascade EWP's Installation Guide. Temporary construction loads which cause stresses beyond design limits are not permitted. Erection bracing shall be provided to assure adequate lateral support for the individual beams and the entire system until the sheathing material has been applied.

**Codes:** VERSA-LAM® beams shall be evaluated by a model code evaluation service.

## Allowable Holes in VERSA-LAM® Beams

### Notes

1. Square and rectangular holes are not permitted.
2. Round holes may be drilled or cut with a hole saw anywhere within the shaded area of the beam.
3. The horizontal distance between adjacent holes must be at least two times the size of the larger hole.
4. Do not drill more than three access holes in any four foot long section of beam.
5. The maximum round hole diameter permitted is:

Beam Depth	Max. Hole Diameter
5½"	¾"
7¼"	1"
9¼" and greater	2"

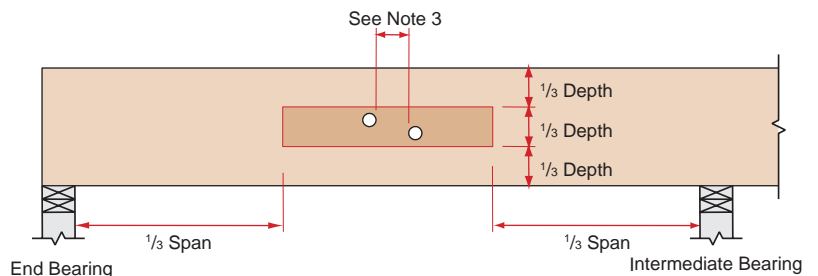

6. These limitations apply to holes drilled for plumbing or wiring access only. The size and location of holes drilled for fasteners are governed by the provisions of the *National Design Specification® for Wood Construction*.
7. Beams deflect under load. Size holes to provide clearance where required.
8. This hole chart is valid for beams supporting uniform load only. For beams supporting concentrated loads or for beams with larger holes, contact Boise Cascade EWP Engineering.

# VERSA-LAM® Beam Details

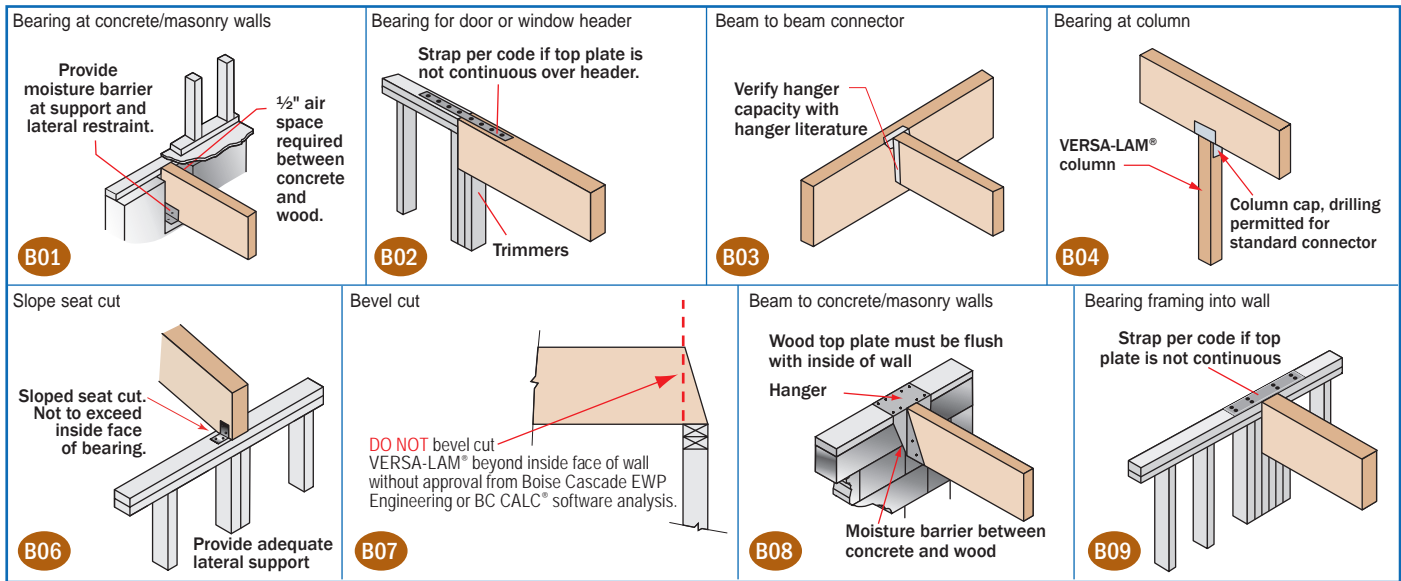

### VERSA-LAM® Installation Notes

- Minimum of 1/2" air space between beam and wall pocket or adequate barrier must be provided between beam and concrete/masonry.
- Adequate bearing shall be provided. If not shown on plans, please refer to load tables in your region's Specifier Guide.
- VERSA-LAM® beams are intended for interior applications only and should be kept as dry as possible during construction.
- Continuous lateral support of top of beam shall be provided (side or top bearing framing).

## Multiple Member Connectors

### Side-Loaded Applications

Number of Members	Maximum Uniform Side Load [plf]							
	Nailed		1/2" Dia. Through Bolt <sup>(1)</sup>				5/8" Dia. Through Bolt <sup>(1)</sup>	
	2 rows 16d Sinkers @ 12" o.c.	3 rows 16d Sinkers @ 12" o.c.	2 rows @ 24" o.c. staggered	2 rows @ 12" o.c. staggered	2 rows @ 6" o.c. staggered	2 rows @ 24" o.c. staggered	2 rows @ 12" o.c. staggered	2 rows @ 6" o.c. staggered
1 1/4" VERSA-LAM® (Depths of 18" and less)								
2	470	705	505	1010	2020	560	1120	2245
3 <sup>(2)</sup>	350	525	375	755	1515	420	840	1685
4 <sup>(3)</sup>	use bolt schedule		335	670	1345	370	745	1495
3/2" VERSA-LAM®								
2 <sup>(3)</sup>	use bolt schedule		855	1715	N/A	1125	2250	N/A

- Design values apply to common bolts that conform to ANSI/ASME standard B18.21-1981 (ASTM A307 Grades A&B, SAE J429 Grades 1 or 2, or higher). A washer not less than a standard cut washer shall be between the wood and the bolt head and between the wood and the nut. The distance from the edge of the beam to the bolt holes must be at least 2" for 1/2" bolts and 2 1/2" for 5/8" bolts. Bolt holes shall be the same diameter as the bolt.
- The nail schedules shown apply to both sides of a three-member beam.
- 7" wide beams must be top-loaded or loaded from both sides.

### Top-Loaded Applications

For top-loaded beams and beams with side loads with less than those shown:

Plies	Depth	Nailing	Maximum Uniform Load From One Side
(2) 1 1/4" plies	Depth 11 1/8" & less	2 rows 16d box/sinker nails @ 12" o.c.	400 plf
	Depth 14" - 18"	3 rows 16d box/sinker nails @ 12" o.c.	600 plf
(3) 1 1/4" plies <sup>(2)</sup>	Depth 11 1/8" & less	2 rows 16d box/sinker nails @ 12" o.c.	300 plf
	Depth 14" - 18"	3 rows 16d box/sinker nails @ 12" o.c.	450 plf
(4) 1 1/4" plies	Depth 18" & less	2 rows 1/2" bolts @ 24" o.c., staggered	335 plf
(2) 3/2" plies	Depth 18" & less	2 rows 1/2" bolts @ 24" o.c., staggered	855 plf
	Depth 20" - 24"	3 rows 1/2" bolts @ 24" o.c., staggered every 8"	1285 plf

- Beams wider than 7" must be designed by the engineer of record.
- All values in these tables may be increased by 15% for snow-load roofs and by 25% for non-snow load roofs where the building code allows.
- Use allowable load tables or BC CALC® software to size beams.
- An equivalent specific gravity of 0.5 may be used when designing specific connections with VERSA-LAM®.
- Connection values are based upon the 2005 NDS.
- FastenMaster TrussLok, Simpson Strong-Tie SDS or SDW, and USP WS screws may also be used to connect multiple member VERSA-LAM® beams, contact Boise Cascade EWP Engineering for further information.

### Designing Connections for Multiple VERSA-LAM® Members

When using multiple ply VERSA-LAM® beams to create a wider member, the connection of the plies is as critical as determining the beam size. When side loaded beams are not connected properly, the inside plies do not support their share of the load and thus the load-carrying capacity of the full member decreases significantly. The following is an example of how to size and connect a multiple-ply VERSA-LAM® floor beam.

Given: Beam shown below is supporting residential floor load (40 psf live load, 10 psf dead load) and is spanning 16'-0". Beam depth is limited to 14".

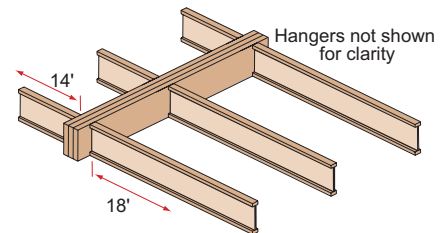

Find: A multiple 1 1/4" ply VERSA-LAM® that is adequate to support the design loads and the member's proper connection schedule.

- Calculate the tributary width that beam is supporting:  
 $14' / 2 + 18' / 2 = 16'$
- Use PLF tables on pages 28-30 of WSG or BC CALC® to size beam.  
A Triple VERSA-LAM® 2.0 2800 1 1/4" x 14" is found to adequately support the design loads.
- Calculate the maximum plf load from one side (the right side in this case).  
 $\text{Max. Side Load} = (18' / 2) \times (40 + 10 \text{ psf}) = 450 \text{ plf}$
- Go to the Multiple Member Connection Table, Side-Loaded Applications, 1 1/4" VERSA-LAM®, 3 members
- The proper connection schedule must have a capacity greater than the max. side load:  
Nailed: 3 rows 16d sinkers @ 12" o.c.: 525 plf is greater than 450 plf OK  
Bolts: 1/2" diameter 2 rows @ 12" staggered: 755 plf is greater than 450 plf OK

## Heavy Storage: 250 psf Live Load / 25 psf Dead Load

O.C. Spacing	1½" VERSA-LAM® 1.7 2400				1¾" VERSA-LAM® 1.7 2400					1¾" VERSA-LAM® 2.0 2800			
	7¼	9¼	11¼	14	7¼	9½	11⅞	14	16	9½	11⅞	14	16
12"	7'-8"	9'-10"	12'-0"	15'-0"	8'-1"	10'-8"	13'-4"	15'-9"	<b>18'-1"</b>	11'-3"	14'-1"	16'-8"	<b>19'-1"</b>
16"	7'-0"	8'-11"	10'-11"	<b>13'-7"</b>	7'-4"	9'-8"	12'-1"	<b>14'-4"</b>	<b>16'-5"</b>	10'-3"	12'-10"	<b>15'-1"</b>	<b>17'-4"</b>
19.2"	6'-7"	8'-5"	<b>10'-3"</b>	<b>12'-9"</b>	6'-11"	9'-1"	<b>11'-5"</b>	<b>13'-6"</b>	<b>15'-5"</b>	9'-7"	<b>12'-0"</b>	<b>14'-3"</b>	<b>16'-3"</b>
24"	5'-10"	7'-6"	<b>9'-1"</b>	<b>11'-4"</b>	6'-5"	8'-5"	<b>10'-7"</b>	<b>12'-6"</b>	<b>14'-3"</b>	<b>8'-11"</b>	<b>11'-2"</b>	<b>13'-2"</b>	<b>15'-1"</b>

- Loading based upon Heavy Storage - Table 1607.1 of 2009 International Building Code.
- Spans limited by allowable moment and reaction values, total load deflection of L/240. Live load deflection limited to L/600 with 50 psf, L/360 with 250 psf.
- Table values represent the most restrictive of simple or multiple span applications.
- Table values are the maximum allowable clear distance between supports.
- This table was designed to apply to a broad range of applications. It may be possible to exceed the limitations of this table by analyzing a specific application with the BC CALC® sizing software.
- Table based upon bearing supports of 2x6 framing.
- **Bold spans indicate applications where bearing wider than 2x6 framing may be needed at intermediate supports.**

## Light Storage: 125 psf Live Load / 25 psf Dead Load

O.C. Spacing	1½" VERSA-LAM® 1.7 2400				1¾" VERSA-LAM® 1.7 2400					1¾" VERSA-LAM® 2.0 2800			
	7¼	9¼	11¼	14	7¼	9½	11⅞	14	16	9½	11⅞	14	16
12"	9'-9"	12'-5"	15'-2"	18'-11"	10'-3"	13'-6"	16'-10"	19'-11"	22'-9"	14'-3"	17'-10"	21'-0"	24'-1"
16"	8'-10"	11'-3"	13'-9"	17'-2"	9'-3"	12'-3"	15'-4"	18'-1"	20'-8"	12'-11"	16'-2"	19'-1"	21'-10"
19.2"	8'-3"	10'-7"	12'-11"	16'-2"	8'-9"	11'-6"	14'-5"	17'-0"	19'-5"	12'-2"	15'-2"	17'-11"	<b>20'-6"</b>
24"	7'-8"	9'-10"	12'-0"	15'-0"	8'-1"	10'-8"	13'-4"	15'-9"	<b>18'-1"</b>	11'-3"	14'-1"	<b>16'-8"</b>	<b>19'-1"</b>

- Loading based upon Light Storage - Table 1607.1 of 2009 International Building Code.
- Spans limited by allowable moment and reaction values, total load deflection of L/240. Live load deflection limited to L/600 with 50 psf, L/360 with 125 psf.
- Table values represent the most restrictive of simple or multiple span applications.
- Table values are the maximum allowable clear distance between supports.
- This table was designed to apply to a broad range of applications. It may be possible to exceed the limitations of this table by analyzing a specific application with the BC CALC® sizing software.
- Table based upon bearing supports of 2x6 framing.
- **Bold spans indicate applications where bearing wider than 2x6 framing may be needed at intermediate supports.**

# VERSA-LAM® Floor Load Tables

## VERSA-LAM® 2.0 2800 and 2.0 3100 (100% Load Duration)

KEY TO TABLE	Top Figure	- Allowable Total Load [plf]
	Middle Figure	- Allowable Live Load [plf]
	Bottom Figures	- Minimum Required Bearing Length at End / Intermediate Supports [inches]

Span [ft]	1 3/4" VERSA-LAM® 2.0 2800 <sup>(1)</sup>						3 1/2" VERSA-LAM® 2.0 3100						5 1/4" VERSA-LAM® 2.0 3100						7" VERSA-LAM® 2.0 3100					
	7 1/2"	9 1/2"	11 1/2"	14"	16" <sup>(2)</sup>	18" <sup>(2)</sup>	7 1/2"	9 1/2"	11 1/2"	14"	16"	18"	9 1/2"	11 1/2"	14"	16"	18"	20"	11 1/2"	14"	16"	18"	20"	24"
6	763	1063	1425	1796	2194	2617	1526	2127	2850	3591	4388	5234	3190	4275	5387	6583	7851	7848	5700	7183	8777	10468	10464	10457
	762	-	-	-	-	-	1525	-	-	-	-	-	-	-	-	-	-	-	-	-	-	-	-	-
7	1.8/4.4	2.4/6.1	3.3/8.2	4.1/10.3	5/12.6	6/15	1.8/4.4	2.4/6.1	3.3/8.2	4.1/10.3	5/12.6	6/15	2.4/6.1	3.3/8.2	4.1/10.3	5/12.6	6/15	6/15	3.3/8.2	4.1/10.3	5/12.6	6/15	6/15	6/15
	614	877	1161	1445	1742	2074	1229	1754	2322	2889	3484	4147	2632	3483	4334	5226	6221	6723	4644	5778	6967	8295	8964	8957
8	1.6/4.1	2.4/5.9	3.1/7.8	3.9/9.7	4.7/11.7	5.6/13.9	1.6/4.1	2.4/5.9	3.1/7.8	3.9/9.7	4.7/11.7	5.6/13.9	2.4/5.9	3.1/7.8	3.9/9.7	4.7/11.7	5.6/13.9	6/15	3.1/7.8	3.9/9.7	4.7/11.7	5.6/13.9	6/15	6/15
	470	746	979	1208	1444	1702	939	1493	1958	2416	2887	3404	2239	2938	3624	4331	5106	5879	3917	4832	5775	6808	7839	7832
9	1.5/3	2.1/5.3	2.9/7.3	3.6/8.9	4.3/10.6	5/12.4	1.5/3	2.1/5.3	2.9/7.3	3.6/8.9	4.3/10.6	5/12.4	2.1/5.3	2.9/7.3	3.6/8.9	4.3/10.6	5/12.4	5.8/14.4	2.9/7.3	3.6/8.9	4.3/10.6	5/12.4	5.8/14.4	6/15
	480	-	-	-	-	-	960	-	-	-	-	-	-	-	-	-	-	-	-	-	-	-	-	-
10	244	500	745	909	1075	1252	487	1000	1491	1819	2150	2504	1500	2236	2728	3225	3756	4326	2981	3638	4299	5008	5768	6257
	165	370	724	-	-	-	329	741	1447	-	-	-	1111	2171	-	-	-	-	2894	-	-	-	-	-
11	1.5/3	1.9/4.8	2.9/7.1	3.5/8.7	4.1/10.3	4.8/12	1.5/3	1.9/4.8	2.9/7.1	3.5/8.7	4.1/10.3	4.8/12	1.9/4.8	2.9/7.1	3.5/8.7	4.1/10.3	4.8/12	5.5/13.8	2.9/7.1	3.5/8.7	4.1/10.3	4.8/12	5.5/13.8	6/15
	182	412	630	809	953	1105	365	825	1260	1618	1906	2211	1237	1890	2428	2858	3316	3803	2520	3237	3811	4422	5071	5684
12	1.5/3	1.7/4.4	2.7/6.7	3.4/8.5	4/10.1	4.7/11.7	1.5/3	1.7/4.4	2.7/6.7	3.4/8.5	4/10.1	4.7/11.7	1.7/4.4	2.7/6.7	3.4/8.5	4/10.1	4.7/11.7	5.4/13.4	2.7/6.7	3.4/8.5	4/10.1	4.7/11.7	5.4/13.4	6/15
	140	317	528	722	856	989	279	635	1057	1444	1711	1979	952	1585	2167	2567	2968	3393	2114	2889	3422	3958	4524	5207
13	1.5/3	1.5/3.7	2.4/6.1	3.3/8.3	3.9/9.9	4.6/11.4	1.5/3	1.5/3.7	2.4/6.1	3.3/8.3	3.9/9.9	4.6/11.4	1.5/3.7	2.4/6.1	3.3/8.3	3.9/9.9	4.6/11.4	5.2/13	2.4/6.1	3.3/8.3	3.9/9.9	4.6/11.4	5.2/13	6/15
	109	249	449	614	776	895	218	497	899	1229	1552	1791	746	1348	1843	2328	2686	3062	1798	2458	3104	3581	4083	4803
14	1.5/3	1.5/3.1	2.3/5.6	3.1/7.7	3.9/9.7	4.5/11.2	1.5/3	1.5/3.1	2.3/5.6	3.1/7.7	3.9/9.7	4.5/11.2	1.5/3.1	2.3/5.6	3.1/7.7	3.9/9.7	4.5/11.2	5.1/12.7	2.3/5.6	3.1/7.7	3.9/9.7	4.5/11.2	5.1/12.7	6/15
	87	198	387	529	682	817	174	396	774	1058	1363	1635	595	1160	1587	2045	2452	2789	1547	2116	2726	3270	3719	4457
15	1.5/3	1.5/3	2.1/5.2	2.9/7.1	3.7/9.2	4.4/11	1.5/3	1.5/3	2.1/5.2	2.9/7.1	3.7/9.2	4.4/11	1.5/3	2.1/5.2	2.9/7.1	3.7/9.2	4.4/11	5/12.5	2.1/5.2	2.9/7.1	3.7/9.2	4.4/11	5/12.5	6/15
	70	160	316	460	593	741	140	321	632	920	1186	1483	481	949	1380	1778	2224	2561	1265	1840	2371	2965	3415	4157
16	1.5/3	1.5/3	1.8/4.6	2.7/6.7	3.4/8.6	4.3/10.7	1.5/3	1.5/3	1.8/4.6	2.7/6.7	3.4/8.6	4.3/10.7	1.5/3	1.8/4.6	2.7/6.7	3.4/8.6	4.3/10.7	4.9/12.3	1.8/4.6	2.7/6.7	3.4/8.6	4.3/10.7	4.9/12.3	6/15
	57	131	260	403	520	651	114	263	519	807	1040	1301	394	779	1210	1560	1952	2367	1039	1614	2080	2602	3156	3894
17	1.5/3	1.5/3	1.6/4	2.5/6.2	3.2/8	4/10	1.5/3	1.5/3	1.6/4	2.5/6.2	3.2/8	4/10	1.5/3	1.6/4	2.5/6.2	3.2/8	4/10	4.9/12.2	1.6/4	2.5/6.2	3.2/8	4/10	4.9/12.2	6/15
	109	216	356	460	575	711	94	218	431	711	920	1151	327	647	1067	1380	1726	2109	862	1423	1840	2302	2812	3658
18	1.5/3	1.5/3	1.9/4.7	2.7/6.8	3.4/8.5	4.1/10.3	1.5/3	1.5/3	1.9/4.7	2.7/6.8	3.4/8.5	4.1/10.3	1.5/3	1.5/3	1.9/4.7	2.7/6.8	3.4/8.5	4.1/10.3	1.5/3	1.9/4.7	2.7/6.8	3.4/8.5	4.1/10.3	5.8/14.6
	65	130	216	325	413	55	130	261	432	649	827	196	391	648	974	1240	1516	521	864	1299	1654	2022	2860	-
19	1.5/3	1.5/3	1.7/4.2	2.5/6.3	3.2/8	4/10	1.5/3	1.5/3	1.7/4.2	2.5/6.3	3.2/8	4/10	1.5/3	1.5/3	1.7/4.2	2.5/6.3	3.2/8	3.9/9.8	1.5/3	1.7/4.2	2.5/6.3	3.2/8	3.9/9.8	5.5/13.8
	46	90	148	221	315	41	93	181	296	442	630	139	271	445	664	945	1296	362	593	885	1260	1728	-	-
20	1.5/3	1.5/3	1.9/4.7	2.7/6.8	3.4/8.5	4.1/10.3	1.5/3	1.5/3	1.9/4.7	2.7/6.8	3.4/8.5	4.1/10.3	1.5/3	1.5/3	1.9/4.7	2.7/6.8	3.4/8.5	4.1/10.3	1.5/3	1.9/4.7	2.7/6.8	3.4/8.5	4.1/10.3	5.8/14.6
	97	161	242	340	441	55	130	261	432	649	827	196	391	648	974	1240	1516	521	864	1299	1654	2022	2860	-
21	1.5/3	1.5/3	1.7/4.2	2.5/6.3	3.2/8	4/10	1.5/3	1.5/3	1.7/4.2	2.5/6.3	3.2/8	4/10	1.5/3	1.5/3	1.7/4.2	2.5/6.3	3.2/8	3.9/9.8	1.5/3	1.7/4.2	2.5/6.3	3.2/8	3.9/9.8	5.5/13.8
	68	111	166	237	327	43	93	181	296	442	630	139	271	445	664	945	1296	362	593	885	1260	1728	-	-
22	1.5/3	1.5/3	1.9/4.7	2.7/6.8	3.4/8.5	4.1/10.3	1.5/3	1.5/3	1.9/4.7	2.7/6.8	3.4/8.5	4.1/10.3	1.5/3	1.5/3	1.9/4.7	2.7/6.8	3.4/8.5	4.1/10.3	1.5/3	1.9/4.7	2.7/6.8	3.4/8.5	4.1/10.3	5.8/14.6
	97	161	242	340	441	55	130	261	432	649	827	196	391	648	974	1240	1516	521	864	1299	1654	2022	2860	-
23	1.5/3	1.5/3	1.7/4.2	2.5/6.3	3.2/8	4/10	1.5/3	1.5/3	1.7/4.2	2.5/6.3	3.2/8	4/10	1.5/3	1.5/3	1.7/4.2	2.5/6.3	3.2/8	3.9/9.8	1.5/3	1.7/4.2	2.5/6.3	3.2/8	3.9/9.8	5.5/13.8
	68	111	166	237	327	43	93	181	296	442	630	139	271	445	664	945	1296	362	593	885	1260	1728	-	-
24	1.5/3	1.5/3	1.9/4.7	2.7/6.8	3.4/8.5	4.1/10.3	1.5/3	1.5/3	1.9/4.7	2.7/6.8	3.4/8.5	4.1/10.3	1.5/3	1.5/3	1.9/4.7	2.7/6.8	3.4/8.5	4.1/10.3	1.5/3	1.9/4.7	2.7/6.8	3.4/8.5	4.1/10.3	5.8/14.6
	73	122	185	265	355	46	113	226	357	531	746	104	204	334	499	710	974	1299	521	864	1299	1654	2022	2860
25	1.5/3	1.5/3	1.7/4.2	2.5/6.3	3.2/8	4/10	1.5/3	1.5/3	1.7/4.2	2.5/6.3	3.2/8	4/10	1.5/3	1.5/3	1.7/4.2	2.5/6.3	3.2/8	3.9/9.8	1.5/3	1.7/4.2	2.5/6.3	3.2/8	3.9/9.8	5.5/13.8
	52	86	128	182	242	32	64	128	211	306	426	588	82	169	285	432	621	858	226	380	575	828	1144	1675
26	1.5/3	1.5/3	1.9/4.7	2.7/6.8	3.4/8.5	4.1/10.3	1.5/3	1.5/3	1.9/4.7	2.7/6.8	3.4/8.5	4.1/10.3	1.5/3	1.5/3	1.9/4.7	2.7/6.8	3.4/8.5	4.1/10.3	1.5/3	1.9/4.7	2.7/6.8	3.4/8.5	4.1/10.3	5.8/14.6
	56	95	144	207	281	37	74	148	221	315	41	93	181	296	442	630	139	271	445	664	945	1296	362	593
27	1.5/3	1.5/3	1.7/4.2	2.5/6.3	3.2/8	4/10	1.5/3	1.5/3	1.7/4.2	2.5/6.3	3.2/8	4/10	1.5/3	1.5/3	1.7/4.2	2.5/6.3	3.2/8	3.9/9.8	1.5/3	1.7/4.2	2.5/6.3	3.2/8	3.9/9.8	5.5/13.8
	41	67	101	143	194	26	52	104	156	218	297	406	63	124	202	302	430	590	165	270	403	574	787	1359
2																								



## VERSA-LAM® 2.0 2800 and 2.0 3100 (115% Load Duration)

KEY TO TABLE	Top Figure - Allowable Total Load [plf]
	Middle Figure - Allowable Live Load [plf]
	Bottom Figures - Minimum Required Bearing Length at End / Intermediate Supports [inches]

Span [ft]	1¾" VERSA-LAM® 2.0 2800 <sup>(1)</sup>						3½" VERSA-LAM® 2.0 3100						5¼" VERSA-LAM® 2.0 3100						7" VERSA-LAM® 2.0 3100											
	7¼"	9½"	11¾"	14"	16" <sup>(2)</sup>	18" <sup>(2)</sup>	7¼"	9½"	11¾"	14"	16"	18"	9½"	11¾"	14"	16"	18"	20"	11¾"	14"	16"	18"	20"	24"						
6	878	1224	1640	2066	2524	2617	1756	2447	3279	4132	5049	5234	3671	4919	6198	7573	7851	7848	6558	8264	10098	10468	10464	10457						
7	2/5	2.8/7	3.8/9.4	4.7/11.8	5.8/14.5	6/15	2/5	2.8/7	3.8/9.4	4.7/11.8	5.8/14.5	6/15	2.8/7	3.8/9.4	4.7/11.8	5.8/14.5	6/15	6/15	3.8/9.4	4.7/11.8	5.8/14.5	6/15	6/15	6/15	6/15	6/15	6/15	6/15	6/15	6/15
8	541	859	1127	1390	1661	1958	1081	1718	2254	2780	3323	3917	2577	3381	4171	4984	5875	5879	4508	5561	6645	7834	7839	7832						
9	426	712	974	1194	1418	1660	853	1423	1948	2389	2837	3321	2135	2923	3583	4255	4981	5223	3897	4778	5673	6642	6964	6957						
10	326	576	858	1047	1237	1441	652	1151	1716	2094	2474	2882	1727	2574	3140	3711	4323	4698	3431	4187	4949	5764	6264	6257						
11	244	475	725	932	1097	1272	488	950	1450	1863	2194	2545	1425	2176	2795	3290	3817	4268	2901	3726	4387	5090	5691	5684						
12	187	398	609	831	985	1139	375	797	1217	1663	1970	2278	1195	1826	2494	2955	3417	3906	2434	3326	3940	4556	5208	5207						
13	147	333	518	708	894	1031	293	666	1035	1415	1787	2062	999	1553	2123	2681	3092	3525	2071	2830	3574	4123	4701	4803						
14	117	266	446	609	785	941	234	532	891	1218	1570	1883	797	1337	1828	2355	2824	3212	1783	2437	3139	3765	4283	4457						
15	94	215	388	530	683	854	189	431	775	1060	1366	1708	646	1163	1590	2048	2561	2949	1550	2119	2731	3415	3932	4157						
16	77	177	340	465	599	749	154	353	680	930	1198	1499	530	1020	1395	1798	2248	2726	1360	1860	2397	2998	3635	3894						
17	64	147	289	411	530	663	128	293	578	822	1060	1326	440	868	1233	1590	1989	2429	1157	1644	2120	2652	3239	3663						
18	53	123	243	366	472	590	106	246	486	732	944	1181	368	728	1098	1416	1771	2164	971	1464	1888	2362	2885	3457						
19	42	95	186	305	455	-	85	191	372	610	910	-	286	558	915	1366	-	-	744	1220	1821	-	-	-						
20	33	73	143	221	362	-	101	226	442	724	-	-	339	663	1086	-	-	-	884	1448	-	-	-	-						
21	26	58	112	181	301	-	77	171	331	561	831	-	265	527	870	1143	1430	1748	702	1160	1524	1907	2330	3107						
22	21	47	91	146	241	-	62	139	271	445	664	945	208	407	667	996	1418	-	543	889	1327	1890	-	-						
23	17	37	71	116	196	-	46	104	204	334	499	710	157	306	501	748	1065	-	408	668	997	1420	-	-						
24	14	30	59	94	151	-	35	77	151	251	411	611	111	231	386	583	836	1023	308	515	777	1115	1364	1933						
25	11	23	45	70	111	-	26	55	107	177	287	447	71	141	231	366	531	746	247	405	604	860	1180	-						
26	9	19	37	56	88	-	20	44	86	141	221	341	51	101	171	266	401	576	193	326	496	714	988	1441						
27	7	15	29	44	71	-	15	33	65	107	177	287	41	81	131	206	316	471	153	253	393	563	813	1166						
28	6	13	25	38	63	-	13	28	55	97	167	277	37	77	127	202	312	467	127	217	337	507	757	1110						
29	5	11	21	32	55	-	11	24	47	81	131	201	31	61	101	166	256	381	117	207	327	497	747	1100						
30	4	9	17	26	47	-	9	20	39	69	119	189	27	57	97	162	252	377	107	197	317	487	737	1090						

(1) For 2-ply, 3-ply or 4-ply beams; double, triple or quadruple Allowable Total Load and Allowable Live Load values. Minimum Required Bearing Lengths remain the same for any number of plies.

(2) 1¾ inch members deeper than 14 inches are to be used as multiple-member beams only.

- Total Load values are limited by shear, moment or deflection equal to L/240. Total Load values are the capacity of the beam in addition to its own weight.
- Live Load values are limited by deflection equal to L/360. Check the local building code for other deflection limits that may apply. Where a Live Load value is not shown, the Total Load value will control.
- Table values represent the most restrictive of simple or multiple span applications. Span is measured center to center of the supports. Analyze multiple span beams with the BC CALC® software if the length of any span is less than half the length of an adjacent span.
- Table values assume that lateral support is provided at each support and continuously along the compression edge of the beam.
- Table values for Minimum Required Bearing Lengths are based on the allowable compression design value perpendicular to grain for the beam and the Total Load value shown. Other design considerations, such as a weaker support material, may warrant longer bearing lengths. Table values assume that support is provided across the full width of the beam.
- This table was designed to apply to a broad range of applications. It may be possible to exceed the limitations of this table by analyzing a specific application with the BC CALC® software.

Boise Cascade EWP • Western Commercial Specifier Guide 01/11/2013

# VERSA-LAM® Roof Load Tables

## VERSA-LAM® 2.0 2800 and 2.0 3100 (125% Load Duration)

KEY TO TABLE	Top Figure - Allowable Total Load [plf]
	Middle Figure - Allowable Live Load [plf]
	Bottom Figures - Minimum Required Bearing Length at End / Intermediate Supports [inches]

Span [ft]	1¾" VERSA-LAM® 2.0 2800 <sup>(1)</sup>						3½" VERSA-LAM® 2.0 3100						5¼" VERSA-LAM® 2.0 3100						7" VERSA-LAM® 2.0 3100					
	7¼"	9½"	11½"	14"	16" <sup>(2)</sup>	18" <sup>(2)</sup>	7¼"	9½"	11½"	14"	16"	18"	9½"	11½"	14"	16"	18"	20"	11½"	14"	16"	18"	20"	24"
6	955	1330	1783	2246	2618	2617	1909	2661	3565	4492	5236	5234	3991	5348	6738	7853	7851	7848	7131	8984	10471	10468	10464	10457
7	769	1098	1453	1807	2179	2242	1538	2195	2905	3615	4358	4484	3293	4358	5422	6537	6726	6723	5810	7229	8716	8968	8964	8957
8	588	934	1225	1512	1806	1961	1176	1868	2451	3023	3613	3921	2802	3676	4535	5419	5882	5879	4901	6047	7226	7843	7839	7832
9	448	774	1059	1299	1542	1742	897	1548	2119	2598	3085	3484	2322	3178	3897	4627	5226	5223	4238	5195	6169	6968	6964	6957
10	326	626	933	1138	1345	1567	652	1252	1866	2277	2691	3134	1878	2799	3415	4036	4701	4698	3732	4554	5381	6268	6264	6257
11	244	517	789	1013	1193	1384	488	1033	1577	2026	2386	2768	1550	2366	3039	3578	4151	4268	3155	4052	4771	5535	5691	5684
12	187	425	662	904	1071	1239	375	849	1324	1809	2142	2478	1274	1986	2713	3214	3716	3911	2648	3617	4285	4955	5214	5207
13	147	333	563	770	972	1121	293	666	1126	1539	1944	2242	999	1690	2309	2916	3363	3608	2253	3078	3888	4485	4810	4803
14	117	266	485	663	854	1024	234	532	970	1325	1707	2048	797	1455	1988	2561	3071	3348	1939	2651	3415	4095	4464	4457
15	94	215	422	576	743	929	189	431	843	1153	1486	1857	646	1265	1729	2228	2786	3123	1687	2306	2971	3715	4164	4157
16	77	177	348	506	652	815	154	353	696	1012	1304	1631	530	1044	1518	1956	2446	2926	1392	2024	2608	3261	3902	3894
17	64	147	289	447	577	721	128	293	578	895	1153	1443	440	868	1342	1730	2164	2643	1157	1790	2307	2885	3524	3663
18	53	123	243	398	514	642	106	246	486	797	1027	1285	368	728	1195	1541	1927	2355	971	1594	2054	2570	3139	3457
19	42	95	186	305	455	-	85	191	372	610	910	-	286	558	915	1366	-	-	744	1220	1821	-	-	-
20	32	72	141	222	332	473	62	139	271	445	664	945	268	527	870	1244	1557	1902	702	1160	1659	2075	2536	3107
22	25	55	108	178	277	417	48	105	208	341	515	746	215	437	718	1044	1370	1706	543	889	1327	1890	-	-
24	20	44	87	139	218	327	38	85	166	277	417	615	171	333	554	816	1111	1446	443	718	1044	1370	1706	2141
26	16	35	69	104	156	234	30	67	133	222	341	515	136	265	437	646	915	1241	341	554	816	1111	1446	1881
28	12	26	51	76	111	163	22	49	97	163	248	357	104	208	341	515	746	1044	248	417	615	881	1241	1809
30	9	19	38	57	86	129	16	35	69	104	156	234	76	151	248	381	546	796	163	277	417	615	881	1241

- (1) For 2-ply, 3-ply or 4-ply beams: double, triple or quadruple Allowable Total Load and Allowable Live Load values. Minimum Required Bearing Lengths remain the same for any number of plies.
- (2) 1¾ inch members deeper than 14 inches are to be used as multiple-member beams only.
- Total Load values are limited by shear, moment or deflection equal to L/240. Total Load values are the capacity of the beam in addition to its own weight.
- Live Load values are limited by deflection equal to L/360. Check the local building code for other deflection limits that may apply. Where a Live Load value is not shown, the Total Load value will control.
- Table values represent the most restrictive of simple or multiple span applications. Span is measured center to center of the supports. Analyze multiple span beams with the BC CALC® software if the length of any span is less than half the length of an adjacent span.
- Table values assume that lateral support is provided at each support and continuously along the compression edge of the beam.
- Table values for Minimum Required Bearing Lengths are based on the allowable compression design value perpendicular to grain for the beam and the Total Load value shown. Other design considerations, such as a weaker support material, may warrant longer bearing lengths. Table values assume that support is provided across the full width of the beam.
- This table was designed to apply to a broad range of applications. It may be possible to exceed the limitations of this table by analyzing a specific application with the BC CALC® software.

## Closest Allowable Nail Spacing VERSA-LAM® & VERSA-RIM® Products

Nail Size	Nailing Parallel to Glue Lines (Narrow Face) <sup>(1)</sup>								Nailing Perpendicular to Glue Lines (Wide Face)	
	VERSA-RIM® 1 1/16"		VERSA-LAM® 1.4 1800 Rimboard 1 7/16"		VERSA-LAM® 1 3/4" & 2 3/8"		VERSA-LAM® 3 1/2" & Wider		All Products	
	O.C. [inches]	End [inches]	O.C. [inches]	End [inches]	O.C. [inches]	End [inches]	O.C. [inches]	End [inches]	O.C. [inches]	End [inches]
8d Box	3	1 1/2	3	1 1/2	2	1	2	1/2	2	1/2
8d Common	4	3	3	2	3	2	2	1	2	1
10d & 12d Box	4	3	3	2	3	2	2	1	2	1
16d Box	4	3	3	2	3	2	2	1	2	1
10d & 12d Common	6	4	4	3	4	3	2	2	2	2
16d Sinkers	6	4	4	3	4	3	2	2	2	2
16d Common	6	4	6	4	6	3	2	2	2	2

Nailing Parallel to Glue Lines (Narrow Face)

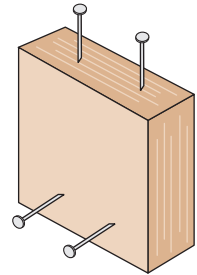

Nailing Perpendicular to Glue Lines (Wide Face)

**Nailing Notes**

- 1) For 1 3/4" thickness and greater, 2 rows of nails (such as for a metal strap) are allowed (use 1/2" minimum offset between rows and stagger nails).

- Offset and stagger nail rows from floor sheathing and wall sole plate.
- Simpson Strong-Tie A35 and LPT4 connectors may be attached to the side VERSA-LAM®/VERSA-RIM®. Use nails as specified by Simpson Strong-Tie.

## VERSA-LAM® Design Values

Grade	Width [in]	Depth [in]	Weight [lb/ft]	Allowable Shear [lb]	Allowable Moment [ft-lb]	Moment of Inertia [in <sup>4</sup> ]
1.7 2400	1 1/2	3 1/2	1.3	998	702	5.4
		5 1/2	2.1	1568	1649	20.8
		7 1/4	2.8	2066	2779	47.6
		9 1/4	3.6	2636	4404	98.9
		11 1/4	4.3	3206	6374	178.0
2.0 2800	1 3/4	5 1/2	2.5	1829	2245	24.3
		7 1/4	3.3	2411	3783	55.6
		9 1/4	4.2	3076	5994	115.4
		9 1/2	4.3	3159	6304	125.0
		11 1/4	5.1	3741	8675	207.6
		11 1/8	5.3	3948	9608	244.2
		14	6.3	4655	13112	400.2
		16	7.2	5320	16874	597.3
2.0 2800	2 5/8	5 1/2	3.7	2743	3368	36.4
		7 1/4	4.9	3616	5675	83.4
		9 1/4	6.2	4613	8991	173.1
		9 1/2	6.4	4738	9455	187.6
		11 1/4	7.6	5611	13013	311.5
		11 1/8	8.0	5923	14412	366.3
		14	9.4	6983	19669	600.3
		16	10.8	7980	25311	896.0
		18	12.1	8978	31618	1275.8
		2.0 3100	3 1/2	5 1/2	4.9	3658
7 1/4	6.5			4821	8377	111.1
9 1/4	8.3			6151	13272	230.8
9 1/2	8.5			6318	13958	250.1
11 1/4	10.1			7481	19210	415.3
11 1/8	10.7			7897	21275	488.4
14	12.6			9310	29035	800.3
16	14.4			10640	37364	1194.7
18	16.2			11970	46674	1701.0
20	18.0			13300	56952	2333.3
2.0 3100	5 1/4	5 1/4	7.1	5237	6830	63.3
		5 1/2	7.4	5486	7457	72.8
		7 1/4	9.8	7232	12566	166.7
		9 1/4	12.5	9227	19908	346.3
		9 1/2	12.8	9476	20937	375.1
		11 1/4	15.2	11222	28814	622.9
		11 1/8	16.0	11845	31913	732.6
		14	18.9	13965	43552	1200.5
		16	21.6	15960	56046	1792.0
		18	24.3	17955	70011	2551.5
		20	27.0	19950	85428	3500.0
		24	32.4	23940	120549	6048.0

Grade	Width [in]	Depth [in]	Weight [lb/ft]	Allowable Shear [lb]	Allowable Moment [ft-lb]	Moment of Inertia [in <sup>4</sup> ]
2.0 3100	7	9 1/4	16.6	12303	26544	461.7
		9 1/2	17.1	12635	27916	500.1
		11 1/4	20.2	14963	38419	830.6
		11 1/8	21.4	15794	42550	976.8
		14	25.2	18620	58069	1600.7
		16	28.8	21280	74728	2389.3
		18	32.4	23940	93348	3402.0
1.4 1800 (Rimboard & Stair Stringers)	1 5/16	20	36.0	26600	113904	4666.7
		24	43.2	31920	160732	8064.0
		9 1/2	3.2	1870	3039	93.8
		11 1/8	4.0	2338	4632	183.2
		14	4.7	2756	6322	300.1
		16	5.4	3150	8136	448.0
		18	6.1	3544	10163	637.9
		20	6.7	3938	12401	875.0

Design Property	VERSA-LAM® Beams		VERSA-LAM® Columns	VERSA-STUD®	Rimboard / Stair Stringers
	1 3/4" & 2 3/8"	3 1/2" & Wider			
Grade	2.0 2800	2.0 3100	1.7 2650	1.7 2400	1.4 1800
Modulus of Elasticity E (x 10 <sup>6</sup> psi) <sup>(1)</sup>	2.0	2.0	1.7	1.7	1.4
Bending F <sub>b</sub> (psi) <sup>(2)(3)</sup>	2800	3100	2650	2400	1800
Horizontal Shear F <sub>v</sub> (psi) <sup>(2)(4)</sup>	285	285	285	285	225
Tension Parallel to Grain F <sub>t</sub> (psi) <sup>(2)(5)</sup>	2150	2150	1650	1650	1250
Compression Parallel to Grain F <sub>c  </sub> (psi) <sup>(2)</sup>	3000	3000	3000	3000	2500
Compression Perpendicular to Grain F <sub>c⊥</sub> (psi) <sup>(1)(6)</sup>	750	750	750	750	525
Equivalent Specific Gravity for Fastener Design (SG)	0.5	0.5	0.5	0.5	0.5

1. This value cannot be adjusted for load duration.
  2. This value is based upon a load duration of 100% and may be adjusted for other load durations.
  3. Fiber stress bending value shall be multiplied by the depth factor, (12/d)<sup>1/8</sup> where d = member depth [in].
  4. Stress applied perpendicular to the glue lines.
  5. Tension value shall be multiplied by a length factor, (4/L)<sup>1/8</sup> where L = member length [ft]. Use L = 4 for members less than four feet long.
  6. Stress applied parallel to the glue lines.
- \* Design properties are limited to dry conditions of use where the maximum moisture content of the material will not exceed 19%.

**BUILDING CODE EVALUATION REPORT:**  
ICC ESR 1040 (IBC, IRC)

# VERSA-LAM® 1.7 2650 Columns

Column Length (ft)	3½" Allowable Axial Load (lb)																	
	3½" x 3½"			3½" x 4%			3½" x 5¼"			3½" x 5½"			3½" x 7"			3½" x 7¼"		
	100%	115%	125%	100%	115%	125%	100%	115%	125%	100%	115%	125%	100%	115%	125%	100%	115%	125%
4	14,700	16,090	16,930	18,390	20,130	21,180	22,070	24,165	25,430	23,130	25,320	26,640	29,450	32,240	33,920	30,500	33,390	35,130
5	12,270	13,150	13,660	15,350	16,440	17,090	18,425	19,740	20,515	19,300	20,680	21,490	24,580	26,330	27,365	25,460	27,270	28,340
6	10,080	10,650	10,980	12,610	13,320	13,740	15,140	15,995	16,495	15,860	16,750	17,280	20,195	21,335	22,000	20,910	22,090	22,780
7	8,310	8,705	8,930	10,400	10,890	11,170	12,480	13,075	13,415	13,080	13,700	14,050	16,650	17,435	17,890	17,250	18,060	18,530
8	6,930	7,205	7,370	8,660	9,010	9,210	10,405	10,825	11,070	10,900	11,340	11,600	13,880	14,440	14,760	14,370	14,960	15,290
9	5,840	6,050	6,160	7,300	7,560	7,710	8,770	9,080	9,260	9,190	9,510	9,700	11,700	12,115	12,350	12,120	12,540	12,790
10	4,980	5,135	5,225	6,230	6,420	6,540	7,480	7,715	7,850	7,830	8,080	8,220	9,975	10,290	10,470	10,330	10,660	10,840
11	4,290	4,410	4,480	5,360	5,520	5,600	6,445	6,625	6,730	6,750	6,940	7,050	8,595	8,835	8,975	8,900	9,150	9,300
12	3,730	3,825	3,880	4,660	4,780	4,850	5,600	5,745	5,830	5,870	6,020	6,100	7,475	7,665	7,775	7,740	7,940	8,050
13	3,270	3,350	3,390	4,090	4,190	4,240	4,915	5,030	5,095	5,150	5,270	5,340	6,555	6,710	6,795	6,790	6,950	7,040
14	2,890	2,950	2,990	3,610	3,690	3,740	4,340	4,435	4,490	4,550	4,650	4,700	5,790	5,915	5,990	6,000	6,130	6,200

Column Length (ft)	5¼" and 7" Allowable Axial Load (lb)																	
	5¼" x 5¼"			5¼" x 5½"			5¼" x 7"			5¼" x 7¼"			7" x 7"			7" x 7¼"		
	100%	115%	125%	100%	115%	125%	100%	115%	125%	100%	115%	125%	100%	115%	125%	100%	115%	125%
6	33,070	36,220	38,110	34,670	37,950	39,930												
7	29,420	31,730	33,085	30,830	33,240	34,660												
8	25,875	27,570	28,565	27,110	28,880	29,930	34,525	36,790	38,115	35,760	38,090	39,480						
9	22,690	23,970	24,715	23,770	25,110	25,900	30,275	31,985	32,980	31,360	33,130	34,160						
10	19,930	20,920	21,495	20,880	21,920	22,520	26,600	27,920	28,685	27,550	28,920	29,710						
11	17,585	18,375	18,820	18,420	19,250	19,720	23,465	24,510	25,125	24,310	25,400	26,010						
12	15,590	16,220	16,585	16,340	16,990	17,380	20,805	21,650	22,130	21,550	22,420	22,930						
13	13,895	14,410	14,700	14,560	15,100	15,400	18,545	19,225	19,620	19,210	19,920	20,320						
14	12,450	12,870	13,115	13,040	13,480	13,740	16,615	17,180	17,500	17,210	17,790	18,130	33,260	34,825	35,740	34,460	36,070	37,030
15	11,210	11,560	11,760	11,740	12,110	12,320	14,960	15,425	15,695	15,490	15,980	16,260	30,325	31,645	32,395	31,410	32,780	33,560
16	10,135	10,430	10,600	10,620	10,930	11,110	13,525	13,920	14,150	14,010	14,420	14,650	27,720	28,835	29,490	28,710	29,870	30,540
17	9,205	9,455	9,600	9,650	9,910	10,060	12,285	12,620	12,810	12,730	13,070	13,270	25,415	26,375	26,920	26,330	27,320	27,880
18	8,395	8,610	8,735	8,800	9,020	9,150	11,205	11,495	11,655	11,610	11,900	12,070	23,370	24,195	24,665	24,210	25,060	25,560
19	7,685	7,870	7,975	8,050	8,250	8,360	10,260	10,505	10,645	10,620	10,880	11,030	21,550	22,270	22,670	22,320	23,070	23,490
20	7,060	7,220	7,310	7,400	7,560	7,660	9,420	9,635	9,760	9,760	9,980	10,110	19,925	20,550	20,910	20,640	21,280	21,660
21	6,505	6,645	6,725	6,820	6,960	7,050	8,680	8,870	8,980	8,990	9,190	9,300	18,475	19,020	19,330	19,130	19,700	20,020
22													17,165	17,650	17,925	17,780	18,280	18,570
23													15,990	16,420	16,660	16,560	17,010	17,260
24													14,930	15,310	15,525	15,460	15,860	16,080

Allowable Design Stresses	
Modulus of Elasticity: $E = 1.7 \times 10^6$ psi	
Bending:	Parallel to Gluelines (Beam): $F_b = 2650 \cdot (12/d)^{1/9}$ psi
	Perp to Gluelines (Plank): $F_b = 2400 \cdot (12/d)^{1/9}$ psi
Compression Parallel to Grain: $F_{cII} = 3000$ psi	
Compression Perpendicular to Grain:	
Parallel to Gluelines (Beam): $F_{c+} = 750$ psi	
Perp to Gluelines (Plank): $F_{c+} = 450$ psi	
Tension Parallel to Grain: $F_t = 1500$ psi	

**Notes**

- 1) Table assumes that the column is braced at column ends only. Effective column length is equal to actual column length.
- 2) Allowable loads are based upon one-piece (solid) column members used in dry service conditions. Contact project's design professional of record or Boise Cascade EWP Engineering for multi-piece column design.
- 3) Allowable loads are based on an eccentricity value equal to 0.167 multiplied by either the column thickness or width (worst case).
- 4) Allowable loads are based on axial loaded columns using the design provisions of the National Design Specification for Wood Construction (NDS), 2005 edition. For side or other combined bending and axial loads, see provisions of NDS, 2005 edition.
- 5) Load values are not shown for short lengths due to loads exceeding common connector capacities. Load values are not shown for longer lengths if the controlling slenderness ratio exceeds 50 (per NDS).
- 6) Lateral loads (wind loading) are not considered in this table.

# VERSA-STUD® 1.7 2400

## Allowable Design Values

Product	Bending $F_b$ [psi]	Compression Parallel to Grain $F_c$ [psi]	Modulus of Elasticity $E$ [psi]	Horizontal Shear $F_v$ [psi]
VERSA-STUD® 1.7 2400	2400	3000	1,700,000	285
Douglas-Fir # 2 Grade	900	1350	1,600,000	180
Spruce Pine Fir (North) # 1 / 2 Grade	875	1150	1,400,000	135
Hem-Fir # 2 Grade	850	1300	1,300,000	150
Western Woods # 2 Grade	675	900	1,000,000	135

**Notes:**

- Design values are for loads applied to the narrow face of the studs.
- Dimension lumber values taken from 2005 Edition, *NDS Design Values for Wood Construction* (per 2006 IBC/IRC).
- Repetitive member and size factors have not been applied.
- For further information, please see VERSA-LAM® 1.7 2400 Wall Guide.

Glued laminated timbers from Boise Cascade Engineered Wood Products add functional beauty to any residential or commercial project.

## Just ask for BOISE GLULAM® beams.

No discussion of engineered wood products is complete without mention of glued laminated timber. Glulams are sometimes forgotten in what has become an increasingly crowded field of newer products.

Laminated timbers are often the most cost-effective and easy-to-install alternative for beam applications to residential, commercial and light industrial construction. It is usually easy to determine whether to specify a balanced or unbalanced layup and whether to choose Industrial or Architectural appearance grade beams.

The benefit to BOISE GLULAM® beams is that they can be manufactured either with or without camber. Most stock beams are available with either a small amount of camber (5,000' radius) or no camber, depending on market demands.

BOISE GLULAM® beams are manufactured from Douglas Fir-Larch and carry the AITC trademark.

### STOCK BEAMS

For most residential applications, stock beams are the product of choice. BOISE GLULAM® stock beams are available through our trusted distributors, located strategically throughout the country. Our beams are manufactured in widths of 3 $\frac{1}{8}$ ", 3 $\frac{1}{2}$ ", 5 $\frac{1}{8}$ ", 5 $\frac{1}{2}$ ", 6 $\frac{3}{4}$ ", and 8 $\frac{3}{4}$ ", with depths ranging from 6" to 24" and lengths up to 66 feet, with or without camber. Stock beams are available in Architectural appearance grade, which is intended for exposed applications but can also be used for concealed beams, headers, columns, and rafters. Check with your local distributor for availability.

### I-JOIST COMPATIBLE BEAMS

IJC (I-Joist Compatible) sizes are readily available. Consult your local distributor for availability. IJC sizes have proven to be cost effective product options to other structural members such as LVL.

### BOISE CEDAR GLULAM™

Cedar glulams provide a green alternative to pressure treated wood in exposed conditions. Due to cedar's natural resistance to decay, these products may be used in above-ground applications, such as decks and balconies. Cedar glulams are available in two species, Alaska yellow and Port Orford and may be designed within the Boise Cascade software suite.



**Rough Sawn Glulam**  
*Just one of our appearance grades*

### KING BEAM™ 3000

A high-strength glulam beam fabricated from select Douglas fir and southern pine laminates. The KING BEAM™ 3000 meets or exceeds all design values of parallel strand lumber, and has all the benefits and cost competitiveness of glulam. Boise Cascade design software and literature allows the product to be analyzed for all structural beam applications.

### LAMINATED WOOD ROOF DECKING

The elegance of laminated wood decking will grace any building design where natural wood is desired. Boise Cascade decking is manufactured from Douglas fir, ponderosa pine, inland red cedar and Alaska yellow cedar. The face is a sound, tight-knot grade that is machine sanded to accentuate the grain and growth characteristics of the wood. The lumber is kiln-dried and laminated with a water-proof exterior phenolic resorcinol adhesive.

### APPEARANCE GRADES

BOISE GLULAM® may be finished to several different appearance grades, which do not have any affect on strength values. As noted, stock beams in standard glulam widths (3 $\frac{1}{8}$ ", 5 $\frac{1}{8}$ ", 6 $\frac{3}{4}$ ", 8 $\frac{3}{4}$ ") are finished to the architectural appearance standard, the perfect look for most all applications. 3 $\frac{1}{2}$ " and 5 $\frac{1}{2}$ " wide beams have a framing grade appearance intended for enclosed applications. Premium appearance is available on a custom order basis for visible commercial and religious structure applications. For an old timber frame look, rough sawn appearance is available on all beams as well.

For availability on these and many other structural wood products,  
please contact BOISE GLULAM® at 800 -237-4013

## ARCHITECTURAL APPEARANCE BEAMS

These beams are the beams of choice in applications where members are exposed to view, because they have a smooth, attractive finish. Stock beams are often supplied with this appearance so they may be exposed to view in the finished structure. Voids greater than 3/4" are filled, three sides (excluding the top) are planed or sanded, and edges are eased on the bottom face of the member.

## INDUSTRIAL APPEARANCE BEAMS

These beams are used in concealed applications or in other places where appearance is not of primary importance, such as such as commercial buildings, warehouses, and garages. Voids are not filled, and only the two wide faces are planed.

## COLUMNS

Glulam columns are straight and dimensionally true, making framing an easy task. Because columns are available in long lengths, the members do not have to be spliced together, as is often necessary with sawn lumber. The columns can be exposed to view as a unique architectural feature of the framing system.

BOISE GLULAM® columns have all four edges eased to match the widths of the Architectural glulams beams and have the same architectural appearance. All sides may be exposed to view.



## FRAMING GRADE APPEARANCE HEADERS

BOISE GLULAM® headers are commonly used in concealed spaces, such as within walls for headers above doors and windows, where appearance is not of importance. BOISE GLULAM® headers are available in two common widths, 3 1/2" and 5 1/2". Please check with your Boise Cascade representative for availability.

## BALANCED AND UNBALANCED BEAM LAYUPS

The most critical areas of a glulam beam are the outside laminations. Thus, the strongest laminations are placed in these areas in either unbalanced or balanced layups.

In unbalanced beams, typically known as V4s, the bottom lamination is stronger than all the other laminations. This allows for a more efficient use of timber resources. It is very important to install unbalanced BOISE GLULAM® beams with the top side up. (*The word "top" is always printed on the corresponding side.*) V4 glulams may be designed and installed in both single and multiple-span applications, and in relatively short cantilevers.

Balanced glulam beams, or V8s, have the same high-strength laminations on both the top and bottom of the beam, creating a symmetric layup. A V8 glulam can be designed for multiple-span conditions and cantilevers. V8s can also be used for single spans, but V4s are most cost-effective for this type of application. V8 BOISE GLULAM® beams may be special ordered at an additional cost; check with your local distributor for availability.

## LAYUP COMBINATIONS

### Balanced Versus Unbalanced Layup Example

No. 2D
No. 2
No. 2
No. 3
No. 2
No. 1
T.L.

Unbalanced (V4)

T.L.
No. 1
No. 2
No. 3
No. 2
No. 1
T.L.

Balanced (V8)

T.L. =  
Tension  
Lamination

## CUSTOM GLULAM PRODUCTS AND CUTS

Larger beams sizes are available on a made-to-order basis, in depths up to 48" and widths of 12¼" or possibly wider subject to inquiry.

Curved beams may be custom ordered for specific length and radius specifications per the project's architect. Beams with standard 1½" thick laminations may be ordered with a radius not smaller than 27.5 ft. For tighter radius beams, ¾" thick laminations are utilized. Both single and double tapered beams may be manufactured for roof beam applications.

Custom cuts for bearing locations, top edges and cantilever ends are possible with the proper specification. Boise Cascade EWP Engineering can provide design assistance to the project's architect or engineer in the sizing of all custom products. For further information on specifications, ordering, and availability, please contact the BOISE GLULAM® sales office at 800-237-4013.

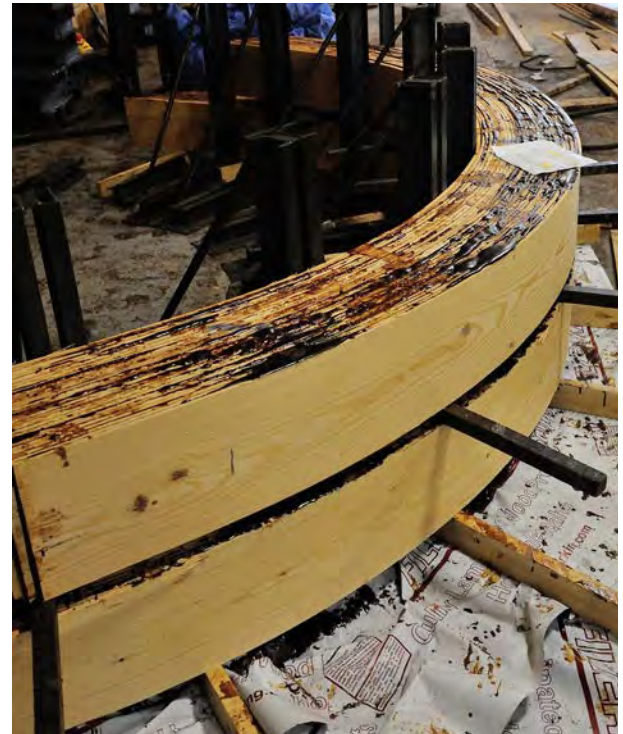

**Clamping of Tight Radius Curve – ¾" Thick Laminations**



**Finished Curved Beams**



**Bevel Top Cut**



## Allowable Design Stresses

Product	Species	Grade	Bending $F_b$ [psi]		Horizontal Shear $F_v$ [psi]	Modulus of Elasticity $E$ [psi]	Compression Parallel to Grain $F_c$ [psi]	Compression Perp to Grain $F_c$ [psi]
			Tension Zone in Tension	Compression Zone in Tension				
BOISE GLULAM®	Douglas fir	24F-V4	2400	1850	265	1,800,000	1650	650
		24F-V8	2400	2400	265	1,800,000	1650	650
		26F-V1	2600	1950	265	2,000,000	1850	650
KING BEAM™ 3000	Douglas fir / SYP	30F-E4	3000	3000	300	2,300,000	1800	650
BOISE CEDAR GLULAM™	Alaska Yellow Cedar	20F-V12	2000	1400	265	1,500,000	1500	560
	Port Orford Cedar	22F-V14	2200	1650	265	1,700,000	2100	560

## Notes:

- Reductions factors shall be applied to design stresses in wet-use conditions.

## BOISE GLULAM® 24F-V4 Design Values

Width (in)	Depth (in)	Weight (plf)	Allowable Shear (lbs)	Allowable Moment (ft-lbs)	Moment of Inertia (in <sup>4</sup> )
3 <sup>1</sup> / <sub>8</sub>	6	4.6	3313	3750	56.3
	7 <sup>1</sup> / <sub>2</sub>	5.7	4141	5859	109.9
	9	6.8	4969	8438	189.8
	10 <sup>1</sup> / <sub>2</sub>	8.0	5797	11484	301.5
	12	9.1	6625	15000	450.0
	13 <sup>1</sup> / <sub>2</sub>	10.3	7453	18984	640.7
	15	11.4	8281	23438	878.9
	16 <sup>1</sup> / <sub>2</sub>	12.5	9109	28359	1169.8
	18	13.7	9938	33750	1518.8
	19 <sup>1</sup> / <sub>2</sub>	14.8	10766	39609	1931.0
	21	16.0	11594	45640	2411.7
	22 <sup>1</sup> / <sub>2</sub>	17.1	12422	52033	2966.3
24	18.2	13250	58821	3600.0	
3 <sup>1</sup> / <sub>2</sub>	4 <sup>1</sup> / <sub>2</sub>	3.8	2783	2363	26.6
	6	5.1	3710	4200	63.0
	7 <sup>1</sup> / <sub>2</sub>	6.4	4638	6563	123.0
	9	7.7	5565	9450	212.6
	10 <sup>1</sup> / <sub>2</sub>	8.9	6493	12863	337.6
	12	10.2	7420	16800	504.0
	13 <sup>1</sup> / <sub>2</sub>	11.5	8348	21263	717.6
	15	12.8	9275	26250	984.4
	16 <sup>1</sup> / <sub>2</sub>	14.0	10203	31763	1310.2
	18	15.3	11130	37709	1701.0
	19 <sup>1</sup> / <sub>2</sub>	16.6	12058	43903	2162.7
	21	17.9	12985	50541	2701.1
	22 <sup>1</sup> / <sub>2</sub>	19.1	13913	57620	3322.3
	24	20.4	14840	65137	4032.0

Width (in)	Depth (in)	Weight (plf)	Allowable Shear (lbs)	Allowable Moment (ft-lbs)	Moment of Inertia (in <sup>4</sup> )
5 <sup>1</sup> / <sub>8</sub>	6	7.5	5433	6150	92.3
	7 <sup>1</sup> / <sub>2</sub>	9.3	6791	9609	180.2
	9	11.2	8149	13838	311.3
	10 <sup>1</sup> / <sub>2</sub>	13.1	9507	18834	494.4
	12	14.9	10865	24600	738.0
	13 <sup>1</sup> / <sub>2</sub>	16.8	12223	30770	1050.8
	15	18.7	13581	37589	1441.4
	16 <sup>1</sup> / <sub>2</sub>	20.6	14939	45052	1918.5
	18	22.4	16298	53151	2490.8
	19 <sup>1</sup> / <sub>2</sub>	24.3	17656	61881	3166.8
	21	26.2	19014	71237	3955.2
	22 <sup>1</sup> / <sub>2</sub>	28.0	20372	81215	4864.7
	24	29.9	21730	91810	5904.0
	25 <sup>1</sup> / <sub>2</sub>	31.8	23088	103019	7081.6
	27	33.6	24446	114837	8406.3
	28 <sup>1</sup> / <sub>2</sub>	35.5	25804	127261	9886.6
	30	37.4	27163	140288	11531.3
	31 <sup>1</sup> / <sub>2</sub>	39.2	28521	153915	13348.9
33	41.1	29879	168139	15348.1	
34 <sup>1</sup> / <sub>2</sub>	43.0	31237	182956	17537.6	
36	44.8	32595	198365	19926.0	



# BOISE GLULAM® 24F-V4 Design Values

Width (in)	Depth (in)	Weight (plf)	Allowable Shear (lbs)	Allowable Moment (ft-lbs)	Moment of Inertia (in <sup>4</sup> )
5½	6	8.0	5830	6600	99.0
	7½	10.0	7288	10313	193.4
	9	12.0	8745	14850	334.1
	10½	14.0	10203	20213	530.6
	12	16.0	11660	26214	792.0
	13½	18.0	13118	32789	1127.7
	15	20.1	14575	40056	1546.9
	16½	22.1	16033	48008	2058.9
	18	24.1	17490	56638	2673.0
	19½	26.1	18948	65941	3398.5
	21	28.1	20405	75912	4244.6
	22¾	30.1	21863	86544	5220.7
	24	32.1	23320	97835	6336.0
	25½	34.1	24778	109779	7599.8
	27	36.1	26235	122372	9021.4
	28½	38.1	27693	135612	10610.0
	30	40.1	29150	149494	12375.0
	31½	42.1	30608	164015	14325.6
	33	44.1	32065	179172	16471.1
	34½	46.1	33523	194962	18820.8
36	48.1	34980	211382	21384.0	
6¾	7½	12.3	8944	12656	237.3
	9	14.8	10733	18225	410.1
	10½	17.2	12521	24457	651.2
	12	19.7	14310	31520	972.0
	13½	22.1	16099	39425	1384.0
	15	24.6	17888	48163	1898.4
	16½	27.1	19676	57724	2526.8
	18	29.5	21465	68102	3280.5
	19½	32.0	23254	79288	4170.9
	21	34.5	25043	91276	5209.3
	22½	36.9	26831	104061	6407.2
	24	39.4	28620	117636	7776.0
	25½	41.8	30409	131998	9327.0
	27	44.3	32198	147140	11071.7
	28½	46.8	33986	163059	13021.4
	30	49.2	35775	179750	15187.5
	31½	51.7	37564	197210	17581.4
	33	54.1	39353	215435	20214.6
34½	56.6	41141	234421	23098.3	
36	59.1	42930	254164	26244.0	
7¼	7½	13.2	9606	13594	254.9
	9	15.9	11528	19459	440.4
	10½	18.5	13449	26081	699.4
	12	21.1	15370	33614	1044.0
	13½	23.8	17291	42044	1486.5
	15	26.4	19213	51362	2039.1
	16½	29.1	21134	61559	2714.0
	18	31.7	23055	72625	3523.5
	19½	34.4	24976	84554	4479.8
	21	37.0	26898	97339	5595.2
	22½	39.6	28819	110973	6881.8
	24	42.3	30740	125450	8352.0
	25½	44.9	32661	140766	10017.9
	27	47.6	34583	156914	11891.8
	28½	50.2	36504	173890	13985.9
	30	52.9	38425	191691	16312.5
	31½	55.5	40346	210310	18883.8
	33	58.2	42268	229745	21711.9
	34½	60.8	44189	249992	24809.3
	36	63.4	46110	271047	28188.0

Width (in)	Depth (in)	Weight (plf)	Allowable Shear (lbs)	Allowable Moment (ft-lbs)	Moment of Inertia (in <sup>4</sup> )
8¾	9	19.1	13913	23048	531.6
	10½	22.3	16231	30891	844.1
	12	25.5	18550	39812	1260.0
	13½	28.7	20869	49798	1794.0
	15	31.9	23188	60834	2460.9
	16½	35.1	25506	72911	3275.5
	18	38.3	27825	86018	4252.5
	19½	41.5	30144	100147	5406.7
	21	44.7	32463	115290	6752.8
	22½	47.9	34781	131438	8305.7
	24	51.0	37100	148585	10080.0
	25½	54.2	39419	166725	12090.6
	27	57.4	41738	185851	14352.2
	28½	60.6	44056	205958	16879.6
	30	63.8	46375	227041	19687.5
	31½	67.0	48694	249094	22790.7
	33	70.2	51013	272113	26204.1
	34 ½	73.4	53331	296094	29942.2
	36	76.6	55650	321032	34020.0
	10¾	12	31.4	22790	47916
13½		35.3	25639	59933	2204.1
15		39.2	28488	73216	3023.4
16½		43.1	31336	87751	4024.2
18		47.0	34185	103527	5224.5
19½		51.0	37034	120531	6642.5
21		54.9	39883	138756	8296.3
22½		58.8	42731	158191	10204.1
24		62.7	45580	178828	12384.0
25½		66.6	48429	200660	14854.1
27		70.5	51278	223679	17632.7
28½		74.5	54126	247879	20737.8
30		78.4	56975	273253	24187.5
31½		82.3	59824	299795	28000.1
33		86.2	62673	327499	32193.6
34½		90.1	65521	356361	36786.2
36		94.1	68370	386375	41796.0
12¼		13½	40.2	29216	67410
	15	44.7	32463	82350	3445.3
	16½	49.1	35709	98698	4585.7
	18	53.6	38955	116441	5953.5
	19½	58.1	42201	135567	7569.4
	21	62.5	45448	156065	9453.9
	22½	67.0	48694	177924	11627.9
	24	71.5	51940	201136	14112.0
	25½	75.9	55186	225691	16926.8
	27	80.4	58433	251582	20093.1
	28½	84.9	61679	278801	23631.4
	30	89.3	64925	307340	27562.5
	31½	93.8	68171	337193	31907.0
	33	98.3	71418	368354	36685.7
	34½	102.7	74664	400816	41919.1
	36	107.2	77910	434574	47628.0

**Notes:**  
 1) Allowable moment calculated using glulam volume factor (C<sub>v</sub>) with a span length of 21 ft. Allowable moment shall be multiplied by (21/Span Length [ft])<sup>1/10</sup> for longer spans.

# BOISE GLULAM® 26F-V1 Design Values

Width (in)	Depth (in)	Weight (plf)	Allowable Shear (lbs)	Allowable Moment (ft-lbs)	Moment of Inertia (in <sup>4</sup> )
3 1/8	6	4.6	3313	4063	56.3
	7 1/2	5.7	4141	6348	109.9
	9	6.8	4969	9141	189.8
	10 1/2	8.0	5797	12441	301.5
	12	9.1	6625	16250	450.0
	13 1/2	10.3	7453	20566	640.7
	15	11.4	8281	25391	878.9
	16 1/2	12.5	9109	30723	1169.8
	18	13.7	9938	36563	1518.8
	19 1/2	14.8	10766	42910	1931.0
	21	16.0	11594	49444	2411.7
	22 3/4	17.1	12422	56369	2966.3
	34 1/2	18.2	13250	63723	3600.0
	24	48.1	34980	211382	21384.0
3 1/2	6	3.8	2783	2559	26.6
	7 1/2	5.1	3710	4550	63.0
	9	6.4	4638	7109	123.0
	10 1/2	7.7	5565	10238	212.6
	12	8.9	6493	13934	337.6
	13 1/2	10.2	7420	18200	504.0
	15	11.5	8348	23034	717.6
	16 1/2	12.8	9275	28438	984.4
	18	14.0	10203	34409	1310.2
	19 1/2	15.3	11130	40851	1701.0
	21	16.6	12058	47561	2162.7
	22 3/4	17.9	12985	54753	2701.1
	34 1/2	19.1	13913	62422	3322.3
	24	20.4	14840	70565	4032.0
5 1/8	6	7.5	5433	6663	92.3
	7 1/2	9.3	6791	10410	180.2
	9	11.2	8149	14991	311.3
	10 1/2	13.1	9507	20404	494.4
	12	14.9	10865	26650	738.0
	13 1/2	16.8	12223	33334	1050.8
	15	18.7	13581	40722	1441.4
	16 1/2	20.6	14939	48806	1918.5
	18	22.4	16298	57580	2490.8
	19 1/2	24.3	17656	67038	3166.8
	21	26.2	19014	77174	3955.2
	22 1/2	28.0	20372	87983	4864.7
	24	29.9	21730	99461	5904.0
	25 1/2	31.8	23088	111604	7081.6
	27	33.6	24446	124407	8406.3
	28 1/2	35.5	25804	137866	9886.6
	30	37.4	27163	151979	11531.3
	31 1/2	39.2	28521	166741	13348.9
33	41.1	29879	182150	15348.1	
34 1/2	43.0	31237	198202	17537.6	
36	44.8	32595	214896	19926.0	

**Notes:**  
 1) Allowable moment calculated using glulam volume factor (C<sub>v</sub>) with a span length of 21 ft. Allowable moment shall be multiplied by (21/Span Length [ft])<sup>1/10</sup> for longer spans.

Width (in)	Depth (in)	Weight (plf)	Allowable Shear (lbs)	Allowable Moment (ft-lbs)	Moment of Inertia (in <sup>4</sup> )
5 1/2	6	8.0	5830	7150	99.0
	7 1/2	10.0	7288	11172	193.4
	9	12.0	8745	16088	334.1
	10 1/2	14.0	10203	21897	530.6
	12	16.0	11660	28399	792.0
	13 1/2	18.0	13118	35521	1127.7
	15	20.1	14575	43394	1546.9
	16 1/2	22.1	16033	52008	2058.9
	18	24.1	17490	61358	2673.0
	19 1/2	26.1	18948	71437	3398.5
	21	28.1	20405	82238	4244.6
	22 1/2	30.1	21863	93757	5220.7
	24	32.1	23320	105988	6336.0
	25 1/2	34.1	24778	118927	7599.8
	27	36.1	26235	132570	9021.4
	28 1/2	38.1	27693	146913	10610.0
	30	40.1	29150	161952	12375.0
	31 1/2	42.1	30608	177683	14325.6
	33	44.1	32065	194103	16471.1
34 1/2	46.1	33523	211208	18820.8	
36	48.1	34980	228997	21384.0	
6 3/4	7 1/2	12.3	8944	13711	237.3
	9	14.8	10733	19744	410.1
	10 1/2	17.2	12521	26495	651.2
	12	19.7	14310	34146	972.0
	13 1/2	22.1	16099	42711	1384.0
	15	24.6	17888	52177	1898.4
	16 1/2	27.1	19676	62535	2526.8
	18	29.5	21465	73777	3280.5
	19 1/2	32.0	23254	85895	4170.9
	21	34.5	25043	98882	5209.3
	22 1/2	36.9	26831	112732	6407.2
	24	39.4	28620	127439	7776.0
	25 1/2	41.8	30409	142997	9327.0
	27	44.3	32198	159402	11071.7
	28 1/2	46.8	33986	176647	13021.4
	30	49.2	35775	194730	15187.5
	31 1/2	51.7	37564	213645	17581.4
33	54.1	39353	233388	20214.6	
34 1/2	56.6	41141	253956	23098.3	
36	59.1	42930	275345	26244.0	
7 1/4	7 1/2	13.2	9606	14727	254.9
	9	15.9	11528	21081	440.4
	10 1/2	18.5	13449	28255	699.4
	12	21.1	15370	36415	1044.0
	13 1/2	23.8	17291	45548	1486.5
	15	26.4	19213	55642	2039.1
	16 1/2	29.1	21134	66689	2714.0
	18	31.7	23055	78677	3523.5
	19 1/2	34.4	24976	91601	4479.8
	21	37.0	26898	105451	5595.2
	22 1/2	39.6	28819	120221	6881.8
	24	42.3	30740	135905	8352.0
	25 1/2	44.9	32661	152496	10017.9
	27	47.6	34583	169990	11891.8
	28 1/2	50.2	36504	188381	13985.9
	30	52.9	38425	207665	16312.5
	31 1/2	55.5	40346	227836	18883.8
	33	58.2	42268	248891	21711.9
	34 1/2	60.8	44189	270825	24809.3
	36	63.4	46110	293635	28188.0

## BOISE GLULAM® IJC 24F-V4 Design Values

Width (in)	Depth (in)	Weight (plf)	Allowable Shear (lbs)	Allowable Moment (ft-lbs)	Moment of Inertia (in <sup>4</sup> )
3½	9½	8.1	5874	10529	250.1
	11¾	10.1	7343	16452	488.4
	14	11.9	8657	22867	800.3
	16	13.6	9893	29867	1194.7
	18	15.3	11130	37709	1701.0
	20	17.0	12367	46066	2333.3
	22	18.7	13603	55212	3105.7
	24	20.4	14840	65137	4032.0
5½	9½	12.7	9231	16546	393.0
	11 7/8	15.9	11539	25698	767.5
	14	18.7	13603	35135	1257.7
	16	21.4	15547	45281	1877.3
	18	24.1	17490	56638	2673.0
	20	26.7	19433	69191	3666.7
	22	29.4	21377	82927	4880.3
	24	32.1	23320	97835	6336.0
7¼	9½	16.7	12168	21565	518.0
	11¾	20.9	15210	32951	1011.7
	14	24.7	17932	45052	1657.8
	16	28.2	20493	58063	2474.7
	18	31.7	23055	72625	3523.5
	20	35.2	25617	88721	4833.3
	22	38.8	28178	106334	6433.2
	24	42.3	30740	125450	8352.0

## BOISE GLULAM® IJC 26F-V1 Design Values

Width (in)	Depth (in)	Weight (plf)	Allowable Shear (lbs)	Allowable Moment (ft-lbs)	Moment of Inertia (in <sup>4</sup> )
3½	9½	8.1	5874	11407	250.1
	11¾	10.1	7343	17823	488.4
	14	11.9	8657	24772	800.3
	16	13.6	9893	32356	1194.7
	18	15.3	11130	40851	1701.0
	20	17.0	12367	49905	2333.3
	22	18.7	13603	59813	3105.7
	24	20.4	14840	70565	4032.0
5½	9½	12.7	9231	17925	393.0
	11¾	15.9	11539	27839	767.5
	14	18.7	13603	38063	1257.7
	16	21.4	15547	49055	1877.3
	18	24.1	17490	61358	2673.0
	20	26.7	19433	74957	3666.7
	22	29.4	21377	89838	4880.3
	24	32.1	23320	105988	6336.0
7¼	9½	16.7	12168	23362	518.0
	11¾	20.9	15210	35697	1011.7
	14	24.7	17932	48806	1657.8
	16	28.2	20493	62901	2474.7
	18	31.7	23055	78677	3523.5
	20	35.2	25617	96115	4833.3
	22	38.8	28178	115196	6433.2
	24	42.3	30740	135905	8352.0

## KING BEAM™ 3000 Design Values

Width (in)	Depth (in)	Weight (plf)	Allowable Shear (lbs)	Allowable Moment (ft-lbs)	Moment of Inertia (in <sup>4</sup> )
3½	7¼	6.2	5075	7665	111.1
	9½	8.1	6650	13161	250.1
	11⅝	10.1	8313	20565	488.4
	14	11.9	9800	28583	800.3
	16	13.6	11200	37333	1194.7
	18	15.3	12600	47136	1701.0
	20	17.0	14000	57583	2333.3
	22	18.7	15400	69015	3105.7
	24	20.4	16800	81421	4032.0
	25	21.7	17850	91362	4836.2
	26	22.1	18200	94795	5126.3
	28	23.8	19600	109128	6402.7
	30	25.5	21000	124414	7875.0
5½	7¼	9.7	7975	12046	174.7
	9½	12.7	10450	20682	393.0
	11⅝	15.9	13063	32122	767.5
	14	18.7	15400	43918	1257.7
	16	21.4	17600	56602	1877.3
	18	24.1	19800	70798	2673.0
	20	26.7	22000	86489	3666.7
	22	29.4	24200	103659	4880.3
	24	32.1	26400	122294	6336.0
	25	34.1	28050	137224	7599.8
	26	34.8	28600	142381	8055.7
	28	37.4	30800	163909	10061.3
	30	40.1	33000	186867	12375.0
7	7¼	12.3	10150	15331	222.3
	9½	16.2	13300	26118	500.1
	11⅝	20.2	16625	39909	976.8
	14	23.8	19600	54564	1600.7
	16	27.2	22400	70322	2389.3
	18	30.6	25200	87959	3402.0
	20	34.0	28000	107454	4666.7
	22	37.4	30800	128786	6211.3
	24	40.8	33600	151938	8064.0
	25	43.4	35700	170487	9672.5
	26	44.2	36400	176894	10252.7
	28	47.6	39200	203641	12805.3
	30	51.0	42000	232164	15750.0

## Alaska Yellow Cedar 20F-V12 Design Values

Width (in)	Depth (in)	Weight (plf)	Allowable Shear (lbs)	Allowable Moment (ft-lbs)	Moment of Inertia (in <sup>4</sup> )
3 3/8	6	4.6	3313	3125	56.3
	7 1/2	5.7	4141	4883	109.9
	9	6.8	4969	7031	189.8
	10 1/2	8.0	5797	9570	301.5
	12	9.1	6625	12500	450.0
	13 1/2	10.3	7453	15820	640.7
	15	11.4	8281	19531	878.9
	16 1/2	12.5	9109	23633	1169.8
	18	13.7	9938	28125	1518.8
	19 1/2	14.8	10766	33008	1931.0
	21	16.0	11594	38034	2411.7
	22 3/4	17.1	12422	43361	2966.3
	24	18.2	13250	49018	3600.0
5 1/8	6	7.5	5433	5125	92.3
	7 1/2	9.3	6791	8008	180.2
	9	11.2	8149	11531	311.3
	10 1/2	13.1	9507	15695	494.4
	12	14.9	10865	20500	738.0
	13 1/2	16.8	12223	25642	1050.8
	15	18.7	13581	31324	1441.4
	16 1/2	20.6	14939	37543	1918.5
	18	22.4	16298	44292	2490.8
	19 1/2	24.3	17656	51567	3166.8
	21	26.2	19014	59364	3955.2
	22 3/4	28.0	20372	67679	4864.7
	24	29.9	21730	76509	5904.0
6 3/4	7 1/2	12.3	8944	10547	237.3
	9	14.8	10733	15188	410.1
	10 1/2	17.2	12521	20381	651.2
	12	19.7	14310	26267	972.0
	13 1/2	22.1	16099	32854	1384.0
	15	24.6	17888	40136	1898.4
	16 1/2	27.1	19676	48104	2526.8
	18	29.5	21465	56751	3280.5
	19 1/2	32.0	23254	66073	4170.9
	21	34.5	25043	76063	5209.3
	22 3/4	36.9	26831	86717	6407.2
	24	39.4	28620	98030	7776.0

**Notes:**

1) Allowable moment calculated using glulam volume factor (C<sub>v</sub>) with a span length of 21 ft. Allowable moment shall be multiplied by (21/Span Length [ft])<sup>1/10</sup> for longer spans.

## Port Orford Cedar 22F-V14 Design Values

Width (in)	Depth (in)	Weight (plf)	Allowable Shear (lbs)	Allowable Moment (ft-lbs)	Moment of Inertia (in <sup>4</sup> )
3 3/8	6	4.6	3313	3438	56.3
	7 1/2	5.7	4141	5371	109.9
	9	6.8	4969	7734	189.8
	10 1/2	8.0	5797	10527	301.5
	12	9.1	6625	13750	450.0
	13 1/2	10.3	7453	17402	640.7
	15	11.4	8281	21484	878.9
	16 1/2	12.5	9109	25996	1169.8
	18	13.7	9938	30938	1518.8
	19 1/2	14.8	10766	36309	1931.0
	21	16.0	11594	41837	2411.7
	22 3/4	17.1	12422	47697	2966.3
	24	18.2	13250	53919	3600.0
5 1/8	6	7.5	5433	5638	92.3
	7 1/2	9.3	6791	8809	180.2
	9	11.2	8149	12684	311.3
	10 1/2	13.1	9507	17265	494.4
	12	14.9	10865	22550	738.0
	13 1/2	16.8	12223	28206	1050.8
	15	18.7	13581	34457	1441.4
	16 1/2	20.6	14939	41297	1918.5
	18	22.4	16298	48721	2490.8
	19 1/2	24.3	17656	56724	3166.8
	21	26.2	19014	65301	3955.2
	22 3/4	28.0	20372	74447	4864.7
	24	29.9	21730	84160	5904.0
6 3/4	7 1/2	12.3	8944	11602	237.3
	9	14.8	10733	16706	410.1
	10 1/2	17.2	12521	22419	651.2
	12	19.7	14310	28893	972.0
	13 1/2	22.1	16099	36140	1384.0
	15	24.6	17888	44149	1898.4
	16 1/2	27.1	19676	52914	2526.8
	18	29.5	21465	62426	3280.5
	19 1/2	32.0	23254	72680	4170.9
	21	34.5	25043	83670	5209.3
	22 3/4	36.9	26831	95389	6407.2
	24	39.4	28620	107833	7776.0

**Notes:**

1) Allowable moment calculated using glulam volume factor (C<sub>v</sub>) with a span length of 21 ft. Allowable moment shall be multiplied by (21/Span Length [ft])<sup>1/10</sup> for longer spans.

BOISE CEDAR GLULAM™ can be used as columns. Please contact BOISE GLULAM® at 800-237-4013 for additional information.

## BOISE GLULAM® COLUMNS





Allowable Axial Load — Combination 3 Column Grade

Column Length [ft]	3 1/8" Wide Column Allowable Axial Load (lb)						5 1/8" Wide Column Allowable Axial Load (lb)								
	3 1/8" x 6"			3 1/8" x 7 1/2"			5 1/8" x 5 1/8"			5 1/8" x 6"			5 1/8" x 7 1/2"		
	100%	115%	125%	100%	115%	125%	100%	115%	125%	100%	115%	125%	100%	115%	125%
4	20,200	22,160	23,340	25,260	27,710	29,180	31,380	35,530	38,170						
5	16,940	18,150	18,850	21,180	22,690	23,570	29,520	33,080	35,340	35,890	40,450	43,330			
6	13,890	14,650	15,090	17,370	18,320	18,860	27,360	30,300	32,110	33,760	37,640	39,950			
7	11,400	11,920	12,210	14,260	14,890	15,270	24,990	27,300	28,690	31,060	33,850	35,520	34,870	37,470	38,990
8	9,460	9,820	10,030	11,830	12,280	12,530	22,530	24,270	25,290	27,870	29,960	31,180	30,990	32,950	34,080
9	7,940	8,210	8,360	9,930	10,260	10,450	20,110	21,440	22,210	24,780	26,340	27,250	27,470	28,960	29,830
10	6,750	6,950	7,060	8,440	8,690	8,830	17,900	18,920	19,520	21,970	23,160	23,850	24,380	25,550	26,220
11	5,800	5,950	6,040	7,250	7,440	7,550	15,940	16,760	17,230	19,490	20,430	20,970	21,700	22,640	23,190
12	5,030	5,150	5,220	6,290	6,440	6,530	14,240	14,900	15,280	17,350	18,110	18,530	19,400	20,160	20,600
13	4,400	4,500	4,550	5,500	5,620	5,698	12,770	13,310	13,610	15,520	16,120	16,480	17,420	18,050	18,410
14							11,500	11,940	12,200	13,930	14,440	14,720	15,720	16,240	16,540
15							10,400	10,770	10,980	12,570	12,980	13,220	14,240	14,670	14,930
16							9,440	9,750	9,930	11,380	11,740	11,930	12,950	13,320	13,530
17							8,600	8,860	9,010	10,350	10,650	10,820	11,820	12,140	12,320
18							7,860	8,090	8,220	9,450	9,710	9,850	10,830	11,110	11,270
19							7,220	7,410	7,520	8,660	8,880	9,010	9,960	10,200	10,340
20							6,640	6,810	6,910	7,960	8,160	8,260	9,190	9,390	9,510
21							6,130	6,280	6,370	7,340	7,510	7,610	8,580	8,780	8,900
22															
23															
24															

Column Length [ft]	6 3/4" Wide Column Allowable Axial Load (lb)						8 3/4" Wide Column Allowable Axial Load (lb)			Notes:
	6 3/4" x 6"			6 3/4" x 7 1/2"			8 3/4" x 9"			
	100%	115%	125%	100%	115%	125%	100%	115%	125%	
4										1) Table assumes that the column is braced at column ends only. Effective column length is equal to actual column length. 2) Allowable loads are based on one-piece column members used in dry service conditions. 3) Allowable loads are based on an eccentricity value equal to 0.167 multiplied by the column thickness or width (worst case). 4) Allowable loads are based on axial loading columns using the design provisions of the National Design Specification for Wood Construction (NDS), 2001 edition. For side or other combined bending and axial loads, use BC CALC® software to analyze such conditions. 5) See below for allowable design stresses. 6) Load values are not shown for short lengths due to loads exceeding common connector capacities. Load values are not shown for longer lengths if the controlling slenderness ratio exceeds 50 (per NDS). 7) It may be possible to exceed the limitations of the table by analyzing a specific application with the BC CALC® software.
5										
6										
7										
8										
9	35,920	38,870	40,620							
10	32,700	35,020	36,390							
11	29,620	31,470	32,540							
12	26,820	28,310	29,180	39,870	42,340	43,790				
13	24,310	25,530	26,240	36,390	38,420	39,600				
14	22,080	23,100	23,680	33,240	34,920	35,900				
15	20,100	20,960	21,460	30,410	31,830	32,640				
16	18,360	19,090	19,500	27,870	29,070	29,760				
17	16,820	17,440	17,800	25,620	26,650	27,230				
18	15,460	15,990	16,300	23,600	24,480	24,990				
19	14,250	14,710	14,970	21,800	22,570	23,000				
20	13,170	13,570	13,800	20,180	20,850	21,240				
21	12,200	12,550	12,750	18,730	19,320	19,650				
22	11,330	11,640	11,820	17,430	17,940	18,240	39,360	41,030	41,950	
23	10,550	10,820	10,980	16,250	16,710	16,970	36,940	38,400	39,250	
24	9,840	10,090	10,230	15,180	15,590	15,820	34,710	36,020	36,760	
25							32,660	33,830	34,510	
26							30,780	31,840	32,440	
27							29,060	30,010	30,560	
28							27,460	28,330	28,830	
29							26,000	26,780	27,240	
30							24,630	25,360	25,780	

## BOISE GLULAM® Column Allowable Design Stresses

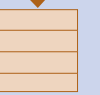
Combination 3 Column Grade

Compression Parallel to Grain F <sub>c</sub> [psi]	Bending F <sub>b</sub> [psi]		Modulus of Elasticity E [psi]		Compression Perpendicular to Grain (limiting direction) F <sub>c</sub> [psi]	Tension Parallel to Grain F <sub>t</sub> [psi]
	Load Perpendicular to Gluelines	Load Parallel to Gluelines	Load Perpendicular to Gluelines	Load Parallel to Gluelines		
<b>2300</b>					<b>650</b>	<b>1450</b>
	<b>2000</b>	<b>2100</b>	<b>1,900,000</b>	<b>1,900,000</b>		

Equivalent specific gravity for fastener design: SG = 0.5.

## BOISE GLULAM® BEAM HANGERS



Width	Depth	Top Mount Hanger		Face Mount Hanger	
		Model No. <sup>(1)</sup>	Allow Load (Floor 100%)	Model No. <sup>(1)</sup>	Allow Load (Floor 100%)
3 1/8"	6"	HW3.25X	5285	HU26-2	1610
	7 1/2"	GLT3	8165	HU28-2	1875
	9" - 10 1/2"	GLT3	8165	HGUS3.25/10	8780
	12"	GLT3	8165	HGUS3.25/12	9155
	13 1/2" - 18"	HGLT3	11590	HGUS3.25/12	9155
3 1/2"	7 1/2"	HW3.56X	5285	HGUS48	6805
	9"	GLTV4	7000	HGUS48	6805
	10 1/2" - 12"	GLTV4	7000	HGUS412	9155
	13 1/2" - 15"	HGLTV4	8665	HGUS414	10015
5 1/8"	6"	HW5.25X	5285	HU38-2	2015
	7 1/2"	GLT5	8165	HU38-2	2015
	9"	GLT5	8165	HU310-2	2015
	10 1/2" - 12"	GLT5	8165	HGUS5.25/12	9155
	13 1/2" - 16 1/2"	HGLT5	11930	HGUS5.25/12	9155
	18" - 19 1/2"	MEG5	19710	HGUS5.25/12	9155
	21" - 24"	EG5	20895	--- <sup>4</sup>	---
5 1/2"	9" - 10 1/2"	GLTV6	7000	HGUS5.50/10	8780
	12"	GLTV6	7000	HGUS5.50/12	9155
6 3/4"	7 1/2"	GLT7	8165	--- <sup>4</sup>	---
	9" - 10 1/2"	GLT7	8165	HGUS6.88/10	8780
	12"	GLT7	8165	HGUS6.88/12	9835
	13 1/2" - 16 1/2"	HGLT7	11930	HGUS6.88/14	11110
	18" - 24"	EG7	25320	HGU7.00	14060
8 3/4"	9" - 10 1/2"	HGLT9	12750	--- <sup>4</sup>	---
	12" - 15"	HGLT9	12750	HGU9.00	14060

- 1) Specify height when ordering.
- 2) Specify width when ordering.
- 3) Loads assume Douglas Fir-Larch/Douglas Fir-Larch configuration, adjust accordingly for other wood species.
- 4) Consult current Simpson products catalog for required fasteners, design values and other information at 1-800-999-5099 or visit their website at [www.strongtie.com](http://www.strongtie.com).

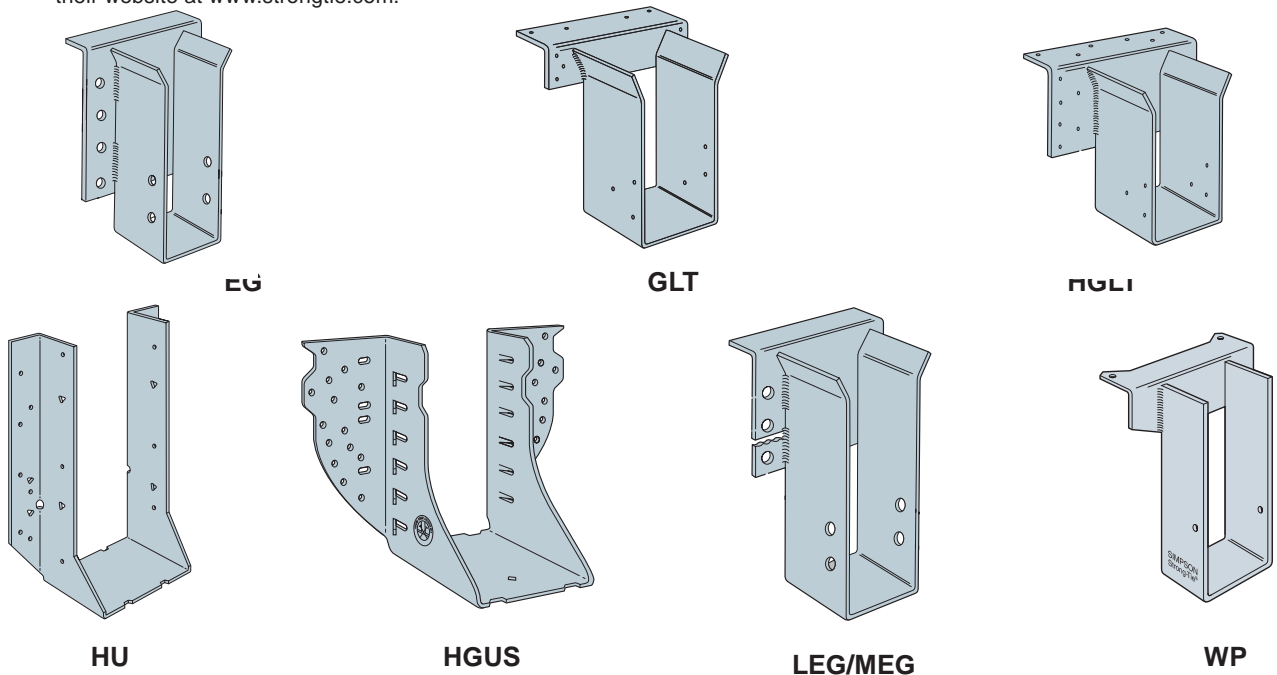

**BOISE GLULAM® BEAM HANGERS**

Width	Depth	Top Mount Hanger		Face Mount Hanger	
		Model No. <sup>(1)</sup>	Allow Load (Floor 100%)	Model No. <sup>(1)</sup>	Allow Load (Floor 100%)
3 1/8"	6"	KHW3	5295	HD26-2	1680
	7 1/2"	KGLT3	7545	HD28-2	1960
	9" - 10 1/2"	KGLT3	7545	THDH3210	8170
	12"	KGLT3	7545	THDH3212	9870
	13 1/2" - 18"	KHGLT3	12965	THDH3212	9870
3 1/2"	7 1/2"	KGLT4	7545	THDH48	6465
	9"	KGLT4	7545	THDH410	8170
	10 1/2" - 12"	KGLT4	7545	THDH412	9875
	13 1/2" - 15"	KGLT4	7545	THDH414	11100
5 1/8"	6"	KGLT5	7545	THDH26-3	3880
	7 1/2"	KGLT5	7545	THDH28-3	6465
	9"	KGLT5	7545	THDH5210	8640
	10 1/2"	KGLT5	7545	THDH5210	8640
	12"	KGLT5	7545	THDH5212	9935
	13 1/2" - 16 1/2"	KHGLT5	12965	THDH614	11645
	18" - 19 1/2"	KMEG5	12185	THDH614	11645
	21" - 24"	KEG5	16115	THDH614	11645
5 1/2"	9" - 10 1/2"	KGLT6	7545	THDH610	8640
	12"	KGLT6	7545	THDH612	9935
6 3/4"	7 1/2"	KGLT7	7545	GHF67750	3505
	9" - 10 1/2"	KGLT7	7545	THDH6710	8170
	12"	KGLT7	7545	THDH6712	9875
	13 1/2" - 16 1/2"	KHGLT7	13400	THDH6714	11580
	18" - 24"	KEG7	17005	THDH6714	11580
8 3/4"	9" - 15"	KHGLT9	13400	-- --	-- --

- Specify height when ordering.
- Loads assume Douglas Fir-Larch header/joist material, adjust for other species.
- KGLT load values based on 460 psi perpendicular to grain loading. KHGLT load values based on 625 psi perpendicular to grain loading.
- Loads depicted are for 100% duration of load factors. Refer to USP Full Line Catalog for load values applicable to other durations of load.
- KEG and KMEG load values are for a supporting member with a width of 5 1/2" and 460 psi perpendicular to grain loading in single shear.
- For additional product information on loading, web stiffeners, nail schedules, and code evaluations, call 1-800-328-5934 or visit their website @ [www.USPconnectors.com](http://www.USPconnectors.com).

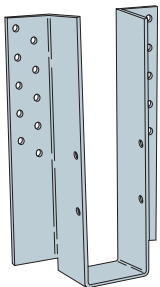

GHF

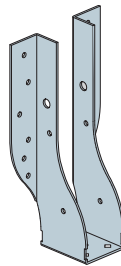

HD

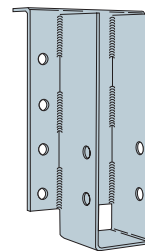

KEG

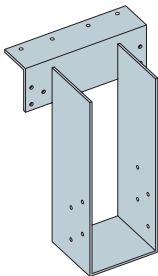

KGLT

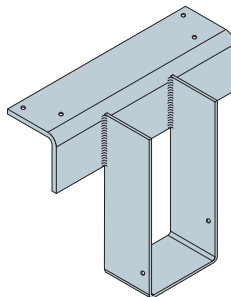

KHW

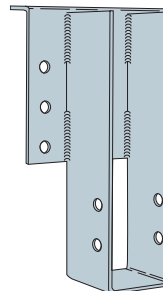

KMEG

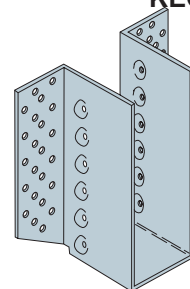

THDH





New BC FRAMER® represents a huge technological leap to help you improve the efficiency and profitability of your engineered wood products business. Boise Cascade will provide you what we believe is now the industry's best design software, offering far greater productivity than even our current version of BC FRAMER®. This new software package will help your design department work faster and accomplish more. You don't get paid to do drawings, but at least now you can do them in less time, and better.

- Shrink design time with BC FRAMER® model sharing.
- Save time & prevent mistakes with best-in-industry file integration.
- Experience the efficiencies of BC FRAMER® whole house modeling.
- Draw floor and wall plans simultaneously with BC FRAMER®.
- Check the plan every possible way with BC FRAMER® full 3-D viewer.
- Create a master plan and multiple options that can be quickly selected and exported to a plot-specific file in a few minutes – a fraction of the time it could have taken in the past.

Information can also be obtained at 1-800-405-5969 or email us at [EWPSupport@BC.com](mailto:EWPSupport@BC.com).

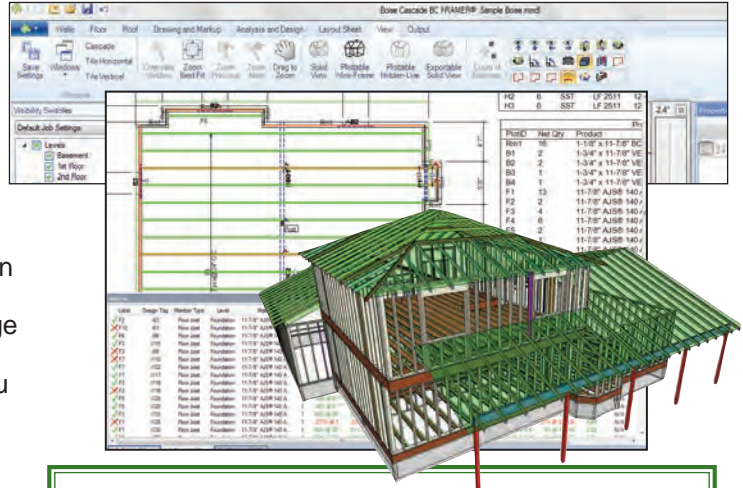

### RECOMMENDED HARDWARE

- **CPU:** Quad Core 64 bit Processor
- **L2 Cache:** 3MB/Core
- **RAM:** 4.0GB to 8.0 GB
- **Video:** Full support for DirectX 9; Single monitors, 1280x1024 128MB; Dual monitor, 1280x1024 256MB (Minimum 1024x768)
- **Operating Systems:** Windows® 7 or 8 (Professional Editions 32-bit and 64-bit)

Actual specifications vary by user and will be assessed prior to installation.

## BC CALC® 4.0 Sizing Software

BC CALC® is simple to use, yet robust enough to analyze most all joist, beam, and column applications. Once an analysis is run, the user may print an easy-to-read design report that displays the span and load information with the analysis results.

BC COLUMN® has now been merged into BC CALC®, allowing the sizing of joists, beams, rafters, columns, and studs all in one convenient program.

In addition to BCI® & AJS® Joists, VERSA-LAM®, and BOISE GLULAM®, BC CALC® also offers the analysis of solid sawn lumber and timber members. Thus BC CALC® is the only program needed to analyze structural wood members.



Boise Cascade has provided BC CALC® free of charge to the design community since 1994.

### COMPUTER REQUIREMENTS

PC with any current version of MS Windows®, along with an internet connection. For questions regarding BC CALC®, call 1-800-405-5969 or email [EWPSupport@BC.com](mailto:EWPSupport@BC.com).

To Download BC CALC US,  
<http://www.bc.com/wood/ewp/software/bccalc.html>

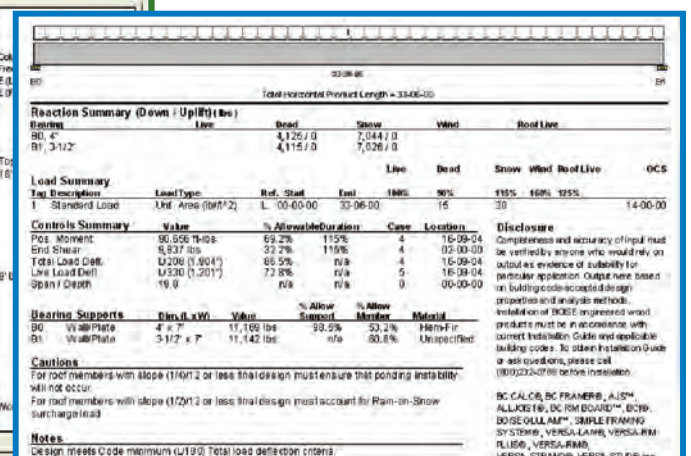
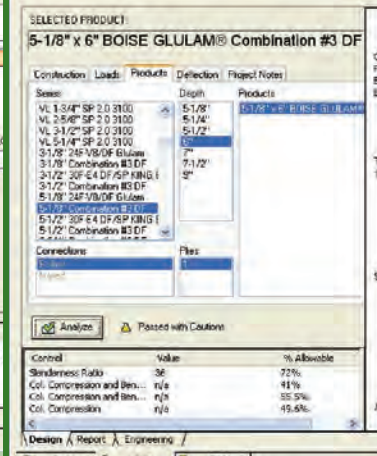
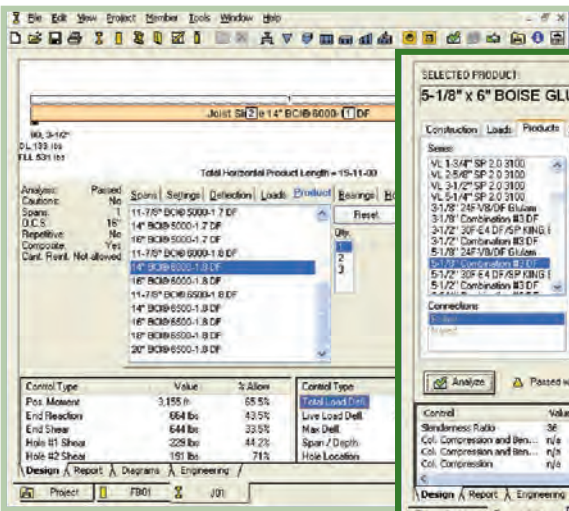

# Framing Connectors - Simpson Strong-Tie

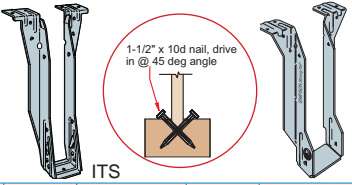
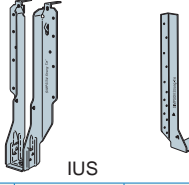
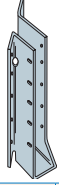
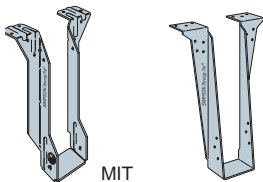
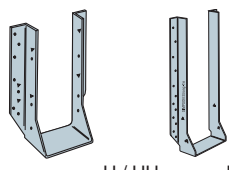
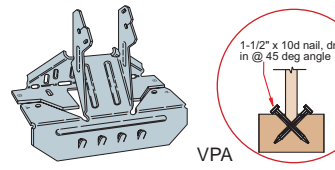
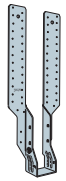
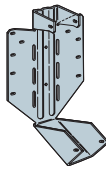

Single Joist - Top Flange						Single Joist - Face Mount						Face Mount Skewed 45° Joist Hanger					
																	
Joist Depth	BCI®	Hanger	Capacity [lbs]	Nailing		Joist Depth	BCI®	Hanger	Capacity [lbs]	Nailing		Joist Depth	BCI®	Hanger	Capacity [lbs]	Nailing	
				Header	Joist					Header	Joist					Header	Joist
9½"	5000 1.7	ITS2.06/9.5	993	6-10d	2-10dx1½"	9½"	5000 1.7	IUS2.06/9.5	935	8-10d	-	9½"	5000 1.7	<i>SUR/L2.06/9</i>	1251	14-16d	6-10dx1½"
	6000 1.8	ITS2.37/9.5	1225	6-10d	2-10dx1½"		6000 1.8	IUS2.37/9.5	935	8-10d	-		6000 1.8	<i>SUR/L2.37/9</i>	1417	14-16d	6-10dx1½"
	6500 1.8	ITS2.56/9.5	1225	6-10d	2-10dx1½"		6500 1.8	IUS2.56/9.5	935	8-10d	-		6500 1.8	<i>SUR/L2.56/9</i>	1417	14-16d	6-10dx1½"
11½"	5000 1.7	ITS2.06/11.88	1068	6-10d	2-10dx1½"	11½"	5000 1.7	IUS2.06/11.88	1068	10-10d	-	11½"	5000 1.7	<i>SUR/L2.06/11</i>	1467	14-16d	6-10dx1½"
	5000 1.8	ITS2.37/11.88	1237	6-10d	2-10dx1½"		6000 1.8	IUS2.37/11.88	1170	10-10d	-		6000 1.8	<i>SUR/L2.37/11</i>	1467	16-16d	6-10dx1½"
	6500 1.8	ITS2.56/11.88	1237	6-10d	2-10dx1½"		6500 1.8	IUS2.56/11.88	1170	10-10d	-		6500 1.8	<i>SUR/L2.56/11</i>	1467	14-16d	2-10dx1½"
14"	60 2.0	ITS2.37/11.88	1210	6-10d	2-10dx1½"	14"	60 2.0	IUS2.37/11.88	1170	10-10d	-	14"	60 2.0	<i>SUR/L2.37/11</i>	1466	14-16d	6-10dx1½"
	90 2.0	ITS3.56/11.88	1478	6-10d	2-10dx1½"		90 2.0	IUS3.56/11.88	1405	10-10d	-		90 2.0	<i>SUR/L410</i>	1860	14-16d	8-16d
	5000 1.7	ITS2.06/14	1081	6-10d	2-10dx1½"		5000 1.7	IUS2.06/14	1081	12-10d	-		5000 1.7	<i>SUR/L2.06/14</i>	1693	18-16d	8-10dx1½"
16"	6000 1.8	ITS2.37/14	1262	6-10d	2-10dx1½"	16"	6000 1.8	IUS2.37/14	1262	12-10d	-	16"	6000 1.8	<i>SUR/L2.37/14</i>	1693	18-16d	8-10dx1½"
	6500 1.8	ITS2.56/14	1262	6-10d	2-10dx1½"		6500 1.8	IUS2.56/14	1262	12-10d	-		6500 1.8	<i>SUR/L2.56/14</i>	1693	18-16d	8-10dx1½"
	60 2.0	ITS2.37/14	1225	6-10d	2-10dx1½"		60 2.0	IUS2.37/14	1225	12-10d	-		60 2.0	<i>SUR/L2.37/14</i>	1689	18-16d	8-10dx1½"
18"	90 2.0	ITS3.56/14	1507	6-10d	2-10dx1½"	18"	90 2.0	IUS3.56/14	1405	12-10d	-	18"	90 2.0	<i>SUR/L414</i>	2035	18-16d	8-16d
	5000 1.8	ITS2.37/16	1268	6-10d	2-10dx1½"		6000 1.8	IUS2.37/16	1268	14-10d	-		6000 1.8	<i>SUR/L2.37/16</i>	1920	18-16d	8-10dx1½"
	6500 1.8	ITS2.56/16	1362	6-16d	2-10dx1½"		6500 1.8	IUS2.56/16	1268	14-10d	-		6500 1.8	<i>SUR/L2.56/16</i>	1920	18-16d	8-10dx1½"
20"	60 2.0	ITS2.37/16	1228	6-16d	2-10dx1½"	20"	60 2.0	IUS2.37/16	1228	14-10d	-	20"	60 2.0	<i>SUR/L2.37/16</i>	1912	18-16d	8-10dx1½"
	90 2.0	ITS3.56/16	1520	6-10d	2-10dx1½"		90 2.0	IUS3.56/16	1640	14-10d	-		90 2.0	<i>SUR/L414</i>	2235	18-16d	8-16d
	90 2.0	<i>MIT418</i>	2400	6-16d	2-10dx1½"		90 2.0	<i>MIU3.56/18</i>	2407	22-16d	2-10dx1½"		90 2.0	<i>SUR/L414</i>	2395	18-16d	8-16d
90 2.0	<i>MIT420</i>	2400	6-16d	2-10dx1½"	90 2.0	<i>MIU3.56/20</i>	2564	24-16d	2-10dx1½"	90 2.0	<i>SUR/L414</i>	2395	18-16d	8-16d			
Double Joist - Top Flange						Double Joist - Face Mount						Variable Pitch Joist Connector					
																	
Joist Depth	BCI®	Hanger	Capacity [lbs]	Nailing		Joist Depth	BCI®	Hanger	Capacity [lbs]	Nailing		Joist Depth	BCI®	Hanger	Capacity [lbs]	Fastener	
				Header	Joist					Header	Joist					Top Plate	Rafter
9½"	5000 1.7	<i>MIT4.12/9.5</i>	2305	10-16d	2-10dx1½"	9½"	5000 1.7	<i>MIU4.12/9</i>	2270	14-16d	6-10d	9½"	5000 1.7	VPA2.06	993	8-10d	2-10dx1½"
	6000 1.8	<i>MIT359.5-2</i>	2400	8-16d	2-10dx1½"		6000 1.8	<i>MIU4.75/9</i>	1860	14-16d	2-10dx1½"		6000 1.8	VPA35	1225	8-10d	2-10dx1½"
	6500 1.8	<i>MIT39.5</i>	2400	8-16d	2-10dx1½"		6500 1.8	<i>MIU5.12/9</i>	2270	14-16d	2-10dx1½"		6500 1.8	VPA3	1225	9-10d	2-10dx1½"
11½"	5000 1.7	<i>MIT4.12/11.88</i>	2305	10-16d	2-10dx1½"	11½"	5000 1.7	<i>MIU4.12/11</i>	2840	16-16d	6-10d	11½"	5000 1.7	VPA2.06	1068	8-10d	2-10dx1½"
	6000 1.8	<i>MIT3511.88-2</i>	2000	8-16d	2-10dx1½"		6000 1.8	<i>MIU4.75/11</i>	2130	16-16d	2-10dx1½"		6000 1.8	VPA35	1230	8-10d	2-10dx1½"
	6500 1.8	<i>MIT311.88-2</i>	2400	8-16d	2-10dx1½"		6500 1.8	<i>MIU5.12/11</i>	2840	16-16d	2-10dx1½"		6500 1.8	VPA3	1230	9-10d	2-10dx1½"
14"	60 2.0	<i>MIT3511.88-2</i>	2000	8-16d	2-10dx1½"	14"	60 2.0	<i>MIU4.75/11</i>	2130	16-16d	2-10dx1½"	14"	60 2.0	VPA35	1210	9-10d	2-10dx1½"
	90 2.0	<i>B7.12/11.88</i>	3785	14-16d	6-16d		90 2.0	<i>HU412-2</i>	2145	16-16d	6-16d		90 2.0	VPA4	1230	11-10d	2-10dx1½"
	5000 1.7	<i>MIT4.12/14</i>	2305	8-16d	2-10dx1½"		5000 1.7	<i>MIU4.12/14</i>	3125	18-16d	2-10dx1½"		5000 1.7	VPA2.06	1081	9-10d	2-10dx1½"
16"	6000 1.8	<i>MIT3514-2</i>	2400	8-16d	2-10dx1½"	16"	6000 1.8	<i>MIU4.75/14</i>	2395	18-16d	2-10dx1½"	16"	6000 1.8	VPA35	1230	9-10d	2-10dx1½"
	6500 1.8	<i>MIT314-2</i>	2400	8-16d	2-10dx1½"		6500 1.8	<i>MIU5.12/14</i>	3125	18-16d	2-10dx1½"		6500 1.8	VPA3	1230	9-10d	2-10dx1½"
	60 2.0	<i>MIT3514-2</i>	2400	8-16d	2-10dx1½"		60 2.0	<i>MIU4.75/14</i>	2395	18-16d	2-10dx1½"		60 2.0	VPA35	1225	9-10d	2-10dx1½"
18"	90 2.0	<i>B7.12/14</i>	3800	14-16d	6-10d	18"	90 2.0	<i>HU414-2</i>	2680	20-16d	8-16d	18"	90 2.0	VPA4	1230	11-10d	2-10dx1½"
	6000 1.8	<i>MIT4.75/16</i>	2305	8-16d	2-10dx1½"		6000 1.8	<i>MIU4.75/16</i>	2660	20-16d	2-10dx1½"		6000 1.8	VPA35	1230	9-10d	2-10dx1½"
	6500 1.8	<i>MIT5.12/16</i>	2400	8-16d	2-10dx1½"		6500 1.8	<i>MIU5.12/16</i>	3125	20-16d	2-10dx1½"		6500 1.8	VPA3	1230	9-10d	2-10dx1½"
20"	60 2.0	<i>MIT4.75/16</i>	2305	3-16d	2-10dx1½"	20"	60 2.0	<i>MIU4.75/16</i>	2660	20-16d	2-10dx1½"	20"	60 2.0	VPA35	1228	9-10d	2-10dx1½"
	90 2.0	<i>B7.12/16</i>	3800	14-16d	6-16d		90 2.0	<i>HU414-2</i>	2680	20-16d	8-16d		90 2.0	VPA4	1230	11-10d	2-10dx1½"
	90 2.0	<i>B7.12/18</i>	3800	3-16d	6-16d		90 2.0	<i>HU414-2</i>	2680	20-16d	8-16d		90 2.0	<i>VPA4</i>	1230	11-10d	2-10dx1½"
90 2.0	<i>B7.12/20</i>	3800	3-16d	6-16d	90 2.0	<i>HU414-2</i>	2680	20-16d	8-16d	90 2.0	<i>VPA4</i>	1230	11-10d	2-10dx1½"			
Adjustable Height Joist Hanger						Field Slope and Skew Joist Hanger											
																	
Joist Depth	BCI®	Hanger	Capacity [lbs]	Nailing		Joist Depth	BCI®	Hanger	Capacity [lbs]	Nailing		Joist Depth	BCI®	Hanger	Capacity [lbs]	Nailing	
				Header	Joist					Header	Joist					Header	Joist
9½"	5000 1.7	<i>THAI2.06/22</i>	1181	6-10d	2-10dx1½"	9½"	5000 1.7	<i>LSSU2.06</i>	995	9-10d	7-10dx1½"	9½"	5000 1.7	<i>LSSU2.06</i>	995	9-10d	7-10dx1½"
	6000 1.8	<i>THAI3522</i>	1393	6-10d	2-10dx1½"		6000 1.8	<i>LSSU315</i>	995	9-10d	7-10dx1½"		6000 1.8	<i>LSSU315</i>	995	9-10d	7-10dx1½"
	6500 1.8	<i>THAI322</i>	1393	6-10d	2-10dx1½"		6500 1.8	<i>LSSUH310</i>	1425	14-10d	12-10dx1½"		6500 1.8	<i>LSSUH310</i>	1425	14-10d	12-10dx1½"
11½"	5000 1.7	<i>THAI2.06/22</i>	1443	6-10d	2-10dx1½"	11½"	5000 1.7	<i>LSSU2.06</i>	995	9-10d	7-10dx1½"	11½"	5000 1.7	<i>LSSU2.06</i>	995	9-10d	7-10dx1½"
	6000 1.8	<i>THAI3522</i>	1443	6-10d	2-10dx1½"		6000 1.8	<i>LSSU315</i>	995	9-10d	7-10dx1½"		6000 1.8	<i>LSSU315</i>	995	9-10d	7-10dx1½"
	6500 1.8	<i>THAI322</i>	1443	6-10d	2-10dx1½"		6500 1.8	<i>LSSUH310</i>	1475	14-10d	12-10dx1½"		6500 1.8	<i>LSSUH310</i>	1475	14-10d	12-10dx1½"
14"	60 2.0	<i>THAI3522</i>	1439	6-10d	2-10dx1½"	14"	60 2.0	<i>LSSU315</i>	995	9-10d	7-10dx1½"	14"	60 2.0	<i>LSSU315</i>	995	9-10d	7-10dx1½"
	90 2.0	<i>THAI422</i>	1715	6-10d	2-10dx1½"		90 2.0	<i>LSSU410</i>	1625	14-16d	12-10dx1½"		90 2.0	<i>LSSU410</i>	1625	14-16d	12-10dx1½"
	5000 1.7	<i>THAI2.06/22</i>	1600	6-10d	2-10dx1½"		5000 1.7	<i>LSSU2.06</i>	995	9-10d	7-10dx1½"		5000 1.7	<i>LSSU2.06</i>	995	9-10d	7-10dx1½"
16"	6000 1.8	<i>THAI3522</i>	1600	6-10d	2-10dx1½"	16"	6000 1.8	<i>LSSU315</i>	995	9-10d	7-10dx1½"	16"	6000 1.8	<i>LSSU315</i>	995	9-10d	7-10dx1½"
	6500 1.8	<i>THAI322</i>	1600	6-10d	2-10dx1½"		6500 1.8	<i>LSSUH310</i>	1600	14-10d	12-10dx1½"		6500 1.8	<i>LSSUH310</i>	1600	14-10d	12-10dx1½"
	60 2.0	<i>THAI3522</i>	1582	6-10d	2-10dx1½"		60 2.0	<i>LSSU315</i>	995	9-10d	7-10dx1½"		60 2.0	<i>LSSU315</i>	995	9-10d	7-10dx1½"
90 2.0	<i>THAI422</i>	1715	6-10d	2-10dx1½"	90 2.0	<i>LSSU410</i>	1625	14-16d	12-10dx1½"	90 2.0	<i>LSSU410</i>	1625	14-16d	12-10dx1½"			

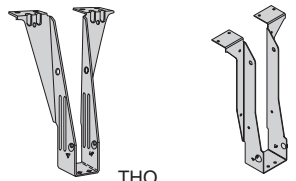
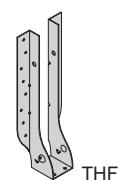
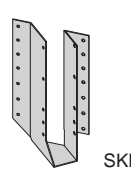

For more information,  
call Simpson Strong-Tie  
at 1-800-999-5099  
or visit their website at  
[www.strongtie.com](http://www.strongtie.com)

- General Notes**
- **Bold Italic hangers require web stiffeners.**
  - Capacities will vary with different nailing criteria and/or support conditions; contact supplier or Simpson Strong-Tie for further information.
  - Capacity values shown are either hanger capacity values (see support requirements below) or BCI® Joist end reaction capacities — whichever is less.
  - All capacity values are downward loads at 100% load duration.
  - Use sloped seat hangers when BCI® Joist slope exceeds ¼" per foot.
  - Use sloped seat hangers and beveled web stiffeners when BCI® Joist slope exceeds ¼" per foot.
  - Leave ¼" clearance (¼" maximum) between the end of the supported joist and the head of the hanger.
  - At max design capacity shown, hangers may exceed standard ¼" deflection by 1/32".
  - For proper installation of the VPA, the 2-10dx1½" joist nails through the bend tabs must be installed at approximately a 45-degree angle.
- Support Requirements**
- **Support material assumed to be VERSA-LAM® or BOISE GLULAM® or sawn lumber (Douglas fir or southern pine species).**
  - Minimum support width for single- and double-joist top mount hangers is 3".
  - Minimum support width for face mount hangers with 10d and 16d nails is 1¾" and 2", respectively.

Single Joist - Top Flange						Single Joist - Face Mount						Face Mount Skewed 45° Joist Hanger					
 <p>THO      TFL</p>						 <p>THF</p>						 <p>SKH</p>					
Joist Depth	BCI®	Hanger	Capacity [lbs]	Nailing		Joist Depth	BCI®	Hanger	Capacity [lbs]	Nailing		Joist Depth	BCI®	Hanger	Capacity [lbs]	Nailing	
				Header	Joist					Header	Joist					Header	Joist
9 1/2"	5000 1.7	TFL2095	993	(6) 10d	2-10dx1 1/2"	9 1/2"	5000 1.7	THF20925	910	(8) 10d	2-10dx1 1/2"	9 1/2"	5000 1.7	SKH2020L/R	1153	(14) 10d	10-10dx1 1/2"
	6000 1.8	TFL2395	1225	(6) 10d	2-10dx1 1/2"	9 1/2"	6000 1.8	THF23925	1275	(12) 10d	2-10dx1 1/2"	9 1/2"	6000 1.8	SKH2320L/R	1384	(14) 10d	10-10dx1 1/2"
	6500 1.8	TFL2595	1225	(6) 10d	2-10dx1 1/2"	9 1/2"	6500 1.8	THF26925	1275	(12) 10d	2-10dx1 1/2"	9 1/2"	6500 1.8	SKH2520L/R	1384	(14) 10d	10-10dx1 1/2"
11 1/2"	5000 1.7	TFL20118	1068	(6) 10d	2-10dx1 1/2"	11 1/2"	5000 1.7	THF20112	910	(8) 10d	2-10dx1 1/2"	11 1/2"	5000 1.7	SKH2020L/R	1434	(16) 10d	10-10dx1 1/2"
	6000 1.8	TFL23118	1237	(6) 10d	2-10dx1 1/2"		6000 1.8	THF23118	1300	(14) 10d	2-10dx1 1/2"		6000 1.8	SKH2320L/R	1434	(16) 10d	10-10dx1 1/2"
	6500 1.8	TFL25118	1237	(6) 10d	2-10dx1 1/2"		6500 1.8	THF26112	1300	(14) 10d	2-10dx1 1/2"		6500 1.8	SKH2520L/R	1434	(16) 10d	10-10dx1 1/2"
14"	60 2.0	TFL23118	1210	(6) 10d	2-10dx1 1/2"	14"	60 2.0	THF23118	1282	(14) 10d	2-10dx1 1/2"	14"	60 2.0	SKH2320L/R	1428	(16) 10d	10-10dx1 1/2"
	90 2.0	THO35118	1558	(10) 10d	2-10dx1 1/2"		90 2.0	THF35112	1585	(16) 10d	2-10dx1 1/2"		90 2.0	SKH410L/R	1892	(16) 16d	10-16d
	5000 1.7	TFL2014	1081	(6) 10d	2-10dx1 1/2"		5000 1.7	THF20140	1081	(12) 10d	2-10dx1 1/2"		5000 1.7	SKH2024L/R	1562	(16) 10d	10-10dx1 1/2"
16"	6000 1.8	TFL2314	1262	(6) 10d	2-10dx1 1/2"	16"	6000 1.8	THF23140	1350	(18) 10d	2-10dx1 1/2"	16"	6000 1.8	SKH2324L/R	1562	(16) 10d	10-10dx1 1/2"
	6500 1.8	TFL2514	1262	(6) 10d	2-10dx1 1/2"		6500 1.8	THF26140	1350	(18) 10d	2-10dx1 1/2"		6500 1.8	SKH2524L/R	1562	(16) 10d	10-10dx1 1/2"
	60 2.0	TFL2314	1225	(6) 10d	2-10dx1 1/2"		60 2.0	THF23140	1325	(18) 10d	2-10dx1 1/2"		60 2.0	SKH2324L/R	1539	(16) 10d	10-10dx1 1/2"
18"	90 2.0	THO35140	1592	(12) 10d	2-10dx1 1/2"	18"	90 2.0	THF35140	1621	(20) 10d	2-10dx1 1/2"	18"	90 2.0	SKH414L/R	2035	(22) 16d	10-16d
	6000 1.8	TFL2316	1268	(6) 10d	2-10dx1 1/2"		6000 1.8	THF23160	1362	(22) 10d	2-10dx1 1/2"		6000 1.8	SKH2324L/R	1690	(16) 10d	10-10dx1 1/2"
	6500 1.8	TFL2516	1268	(6) 10d	2-10dx1 1/2"		6500 1.8	THF26160	1362	(22) 10d	2-10dx1 1/2"		6500 1.8	SKH2524L/R	1690	(16) 10d	10-10dx1 1/2"
20"	60 2.0	TFL2316	1228	(6) 10d	2-10dx1 1/2"	20"	60 2.0	THF23160	1335	(22) 10d	2-10dx1 1/2"	20"	60 2.0	SKH2324L/R	1650	(16) 10d	10-10dx1 1/2"
	90 2.0	THO35160	1626	(12) 10d	2-10dx1 1/2"		90 2.0	THF35157	1657	(22) 10d	2-10dx1 1/2"		90 2.0	SKH414L/R	2235	(22) 16d	10-16d
	90 2.0	THO35180	2389	(14) 10d	2-10dx1 1/2"		90 2.0	THF35165	2407	(24) 10d	8-10dx1 1/2"		90 2.0	SKH418L/R	2407	(28) 16d	10-16d
90 2.0	THO35200	2553	(14) 10d	2-10dx1 1/2"	90 2.0	THF35165	2564	(24) 10d	8-10dx1 1/2"	90 2.0	SKH418L/R	2564	(28) 16d	10-16d			

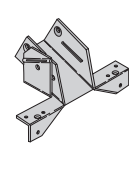
Double Joist - Top Flange						Double Joist - Face Mount						Variable Pitch Joist Connector					
 <p>THO Double      BPH</p>						 <p>THF Double      HD</p>						 <p>TMP</p>					
Joist Depth	BCI®	Hanger	Capacity [lbs]	Nailing		Joist Depth	BCI®	Hanger	Capacity [lbs]	Nailing		Joist Depth	BCI®	Hanger	Capacity [lbs]	Fastener	
				Header	Joist					Header	Joist					Top Plate	Rafter
9 1/2"	5000 1.7	<b>THO20950-2</b>	2330	(10) 16d	6-10d	9 1/2"	5000 1.7	<b>THF20925-2</b>	1390	(12) 10d	6-10d	9 1/2"	5000 1.7	TMP21	1125	(6) 10d	4-10dx1 1/2"
	6000 1.8	<b>THO23950-2</b>	2825	(10) 10d	6-10d	9 1/2"	6000 1.8	<b>THF23925-2</b>	1625	(14) 10d	6-10d	9 1/2"	6000 1.8	TMP23	1375	(6) 10d	4-10dx1 1/2"
	6500 1.8	<b>THO25950-2</b>	2650	(10) 16d	6-10d	9 1/2"	6500 1.8	<b>THF26925-2</b>	1390	(12) 10d	6-10d	9 1/2"	6500 1.8	TMP25	1375	(6) 10d	4-10dx1 1/2"
11 1/2"	5000 1.7	<b>THO20118-2</b>	2330	(10) 16d	6-10d	11 1/2"	5000 1.7	<b>THF20112-2</b>	1855	(16) 10d	6-10d	11 1/2"	5000 1.7	TMP21	1150	(6) 10d	4-10dx1 1/2"
	6000 1.8	<b>THO23118-2</b>	2925	(10) 10d	6-10d		6000 1.8	<b>THF23118-2</b>	1855	(16) 10d	6-10d		6000 1.8	TMP23	1425	(6) 10d	4-10dx1 1/2"
	6500 1.8	<b>THO25118-2</b>	2925	(10) 16d	6-10d		6500 1.8	<b>THF26112-2</b>	1855	(16) 10d	6-10d		6500 1.8	TMP25	1425	(6) 10d	4-10dx1 1/2"
14"	60 2.0	<b>THO23118-2</b>	2921	(10) 16d	6-10d	14"	60 2.0	<b>THF23118-2</b>	1855	(16) 10d	6-10d	14"	60 2.0	TMP23	1425	(6) 10d	4-10dx1 1/2"
	90 2.0	<b>BPH71118</b>	3455	(10) 16d	6-10d		90 2.0	<b>HD7120</b>	2255	(16) 16d	6-10d		90 2.0	TMP4	1800	(6) 10d	4-10dx1 1/2"
	5000 1.7	<b>THO20140-2</b>	2330	(10) 16d	6-10d		5000 1.7	<b>THF20140-2</b>	2320	(20) 10d	6-10d		5000 1.7	TMP21	1150	(6) 10d	4-10dx1 1/2"
16"	6000 1.8	<b>THO23140-2</b>	3350	(12) 10d	6-10d	16"	6000 1.8	<b>THF23140-2</b>	2540	(20) 10d	6-10d	16"	6000 1.8	TMP23	1525	(6) 10d	4-10dx1 1/2"
	6500 1.8	<b>THO25140-2</b>	3050	(12) 16d	6-10d		6500 1.8	<b>THF26140-2</b>	2500	(20) 10d	6-10d		6500 1.8	TMP25	1525	(6) 10d	4-10dx1 1/2"
	60 2.0	<b>THO23140-2</b>	3335	(12) 16d	6-10d		60 2.0	<b>THF23140-2</b>	2540	(20) 10d	6-10d		60 2.0	TMP23	1525	(6) 10d	4-10dx1 1/2"
18"	90 2.0	<b>BPH7114</b>	3455	(10) 16d	6-10d	18"	90 2.0	<b>HD7140</b>	2820	(20) 16d	6-10d	18"	90 2.0	TMP4	1850	(6) 10d	4-10dx1 1/2"
	6000 1.8	<b>THO23160-2</b>	3535	(12) 16d	6-10d		6000 1.8	<b>THF23160-2</b>	3050	(24) 10d	6-10d		6000 1.8	TMP23	1550	(6) 10d	4-10dx1 1/2"
	6500 1.8	<b>THO25160-2</b>	3535	(12) 16d	6-10d		6500 1.8	<b>THF26160-2</b>	3000	(24) 10d	6-10d		6500 1.8	TMP25	1550	(6) 10d	4-10dx1 1/2"
20"	60 2.0	<b>THO23160-2</b>	3535	(12) 16d	6-10d	20"	60 2.0	<b>THF23160-2</b>	3050	(24) 10d	6-10d	20"	60 2.0	TMP23	1550	(6) 10d	4-10dx1 1/2"
	90 2.0	<b>BPH7116</b>	3455	(10) 16d	6-10d		90 2.0	<b>HD7160</b>	3385	(24) 16d	6-10d		90 2.0	TMP4	1900	(6) 10d	4-10dx1 1/2"
	90 2.0	<b>BPH7118</b>	3510	(10) 16d	6-10d		90 2.0	<b>HD7180</b>	3920	(28) 16d	6-10d		90 2.0	TMP4	1970	(6) 10d	4-10dx1 1/2"
90 2.0	<b>BPH7120</b>	3510	(10) 16d	6-10d	90 2.0	<b>HD7180</b>	3920	(28) 16d	6-10d	90 2.0	TMP4	1970	(6) 10d	4-10dx1 1/2"			

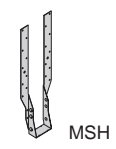
Adjustable Height Joist Hanger					
 <p>MSH</p>					
Joist Depth	BCI®	Hanger	Capacity [lbs]	Nailing	
				Header	Joist
9 1/2"	5000 1.7	-	-	-	-
	6000 1.8	<b>MSH2318</b>	1381	(6) 10d	4-10dx1 1/2"
	6500 1.8	<b>MSH318</b>	1381	(6) 10d	4-10dx1 1/2"
11 1/2"	5000 1.7	-	-	-	-
	6000 1.8	<b>MSH2318</b>	1431	(6) 10d	4-10dx1 1/2"
	6500 1.8	<b>MSH318</b>	1431	(6) 10d	4-10dx1 1/2"
14"	60 2.0	<b>MSH2318</b>	1425	(6) 10d	4-10dx1 1/2"
	90 2.0	<b>MSH422</b>	1850	(6) 10d	6-10d
	5000 1.7	-	-	-	-
14"	6000 1.8	<b>MSH2322</b>	1550	(6) 10d	4-10dx1 1/2"
	6500 1.8	<b>MSH318</b>	1550	(6) 10d	4-10dx1 1/2"
	60 2.0	<b>MSH2322</b>	1525	(6) 10d	4-10dx1 1/2"
90 2.0	<b>MSH422</b>	1950	-	-	6-10d

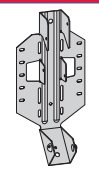
Field Slope and Skew Joist Hanger					
 <p>LSSH</p>					
Joist Depth	BCI®	Hanger	Capacity [lbs]	Nailing	
				Header	Joist
9 1/2"	5000 1.7	<b>LSSH20</b>	1140	(10) 10d	7-10dx1 1/2"
	6000 1.8	<b>LSSH23</b>	1140	(10) 10d	7-10dx1 1/2"
	6500 1.8	<b>LSSH25</b>	1412	(14) 10d	12-10dx1 1/2"
11 1/2"	5000 1.7	<b>LSSH20</b>	1140	(10) 10d	7-10dx1 1/2"
	6000 1.8	<b>LSSH23</b>	1140	(10) 10d	7-10dx1 1/2"
	6500 1.8	<b>LSSH25</b>	1462	(14) 10d	12-10dx1 1/2"
14"	60 2.0	<b>LSSH23</b>	1140	(10) 10d	7-10dx1 1/2"
	90 2.0	<b>LSSH35</b>	1920	(14) 16d	12-10dx1 1/2"
	5000 1.7	<b>LSSH20</b>	1140	(10) 10d	7-10dx1 1/2"
14"	6000 1.8	<b>LSSH23</b>	1140	(10) 10d	7-10dx1 1/2"
	6500 1.8	<b>LSSH25</b>	1675	(14) 10d	12-10dx1 1/2"
	60 2.0	<b>LSSH23</b>	1140	(10) 10d	7-10dx1 1/2"
90 2.0	<b>LSSH35</b>	1920	(14) 16d	12-10dx1 1/2"	

**USP**  
STRUCTURAL CONNECTORS  
A Miltek Company

For more information, contact USP Lumber Connectors at 1-800-328-5934 or [www.uspconnectors.com](http://www.uspconnectors.com)

**General Notes**

- **Bold italic hangers required web stiffeners.**
- Capacities will vary with different nailing criteria and/or support conditions: contact supplier or USP Lumber Connectors for further information.
- Capacity values shown are either hanger capacity values (see support requirements below) or BCI® Joist end reaction capacities — whichever is less.
- All capacity values are downward loads at 100% load duration.
- Use sloped seat hangers when BCI joist slope exceeds 1/4" per foot.
- Use sloped seat hangers and beveled web stiffeners when BCI® Joist slope exceeds 1/4" per foot.
- Leave 1/16" clearance (1/8" maximum) between the end of the supported joist and the head of the hanger.

**Support Requirements**

- Support material assumed to be **VERSA-LAM®** or **BOISE GLULAM®** or **sawn lumber (Douglas fir or southern pine species)**.
- Minimum support width for single- and double-joist top mount hangers is 3"; (1 1/2" for THO hangers).
- Minimum support width for face mount hangers with 10d and 16d nails is 1 1/2" and 2", respectively.

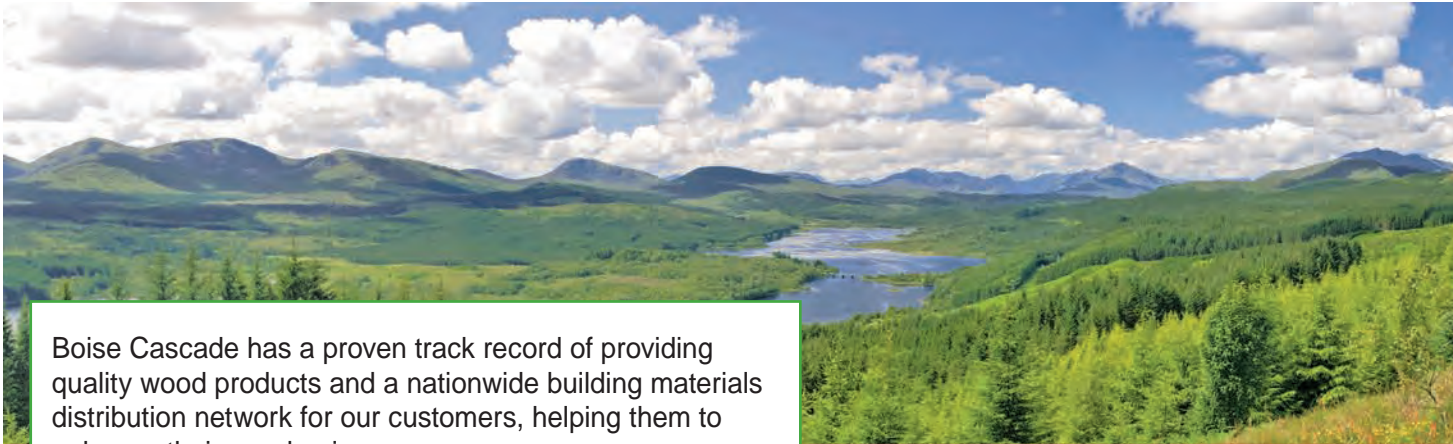

Boise Cascade has a proven track record of providing quality wood products and a nationwide building materials distribution network for our customers, helping them to enhance their own businesses.

Boise Cascade Engineered Wood Products build better homes with stronger, stiffer floors using only wood purchased in compliance with a number of green building programs. Take a moment to view our sustainability certification site at <http://www.bc.com/sustainability/certification.html> or view our green brochure at [http://www.bc.com/wood/ewp/Boise\\_EWP\\_Green.html](http://www.bc.com/wood/ewp/Boise_EWP_Green.html).

Boise Cascade Engineered Wood Products throughout North America can now be ordered FSC® Chain-of-Custody (COC) certified, enabling homebuilders to achieve LEED® points under U.S. Green Building Council® residential and commercial green building programs including LEED for Homes and LEED for New Construction. Boise Cascade Engineered Wood Products are available as PEFC® Chain-of-Custody certified, SFI® Chain-of-Custody certified and SFI Fiber-Sourcing certified, as well as NAHB Research Center Green Approved, enabling homebuilders to also obtain green building points through the National Green Building Standard.

### Lifetime Guaranteed Quality and Performance

Boise Cascade warrants its BCI® Joist, VERSA-LAM®, and ALLJOIST® products to comply with our specifications, to be free from defects in material and workmanship, and to meet or exceed our performance specifications for the normal and expected life of the structure when correctly stored, installed and used according to our Installation Guide.

If in doubt, ask!  
For the number of the closest  
Boise Cascade EWP  
distributor/support center, call  
800-232-0788

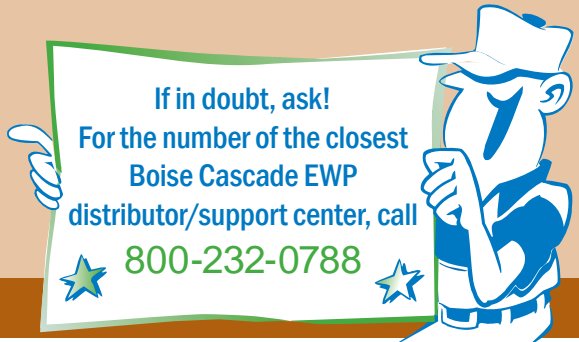

BOISE CASCADE, TREE-IN-A-CIRCLE, BCI, BC CALC, BC COLUMN, BC FRAMER, BC RIM BOARD, BOISE GLULAM, SIMPLE FRAMING SYSTEM, VERSA-LAM, VERSA-RIM, VERSA-STRAND, and VERSA-STUD are trademarks of Boise Cascade, L.L.C. or its affiliates.

For information about  
Boise Cascade Engineered Wood Products,  
including sales terms and conditions,  
warranties and disclaimers,  
visit our website at [www.BCewp.com](http://www.BCewp.com)

Your Dealer is:

If no dealer is listed, call 1-800-232-0788



**Boise Cascade**  
Engineered Wood Products

*Great products are only the beginning.®*